

SPECIFICATIONS

PARAMETERS	VALUES	UNITS
DIRECTIVITY	OMNI	-
SENSITIVITY	-44 ± 3	dB
STANDARD OPERATING VOLTAGE	2	Vdc
MAX OPERATING VOLTAGE	10	Vdc
CURRENT CONSUMPTION (MAX)	0.5	mA
IMPEDANCE	2.2	KOhm
SIGNAL TO NOISE RATIO (MIN.)	60	dB
OPERATING TEMPERATURE	-20 ~ +70	C°
STORAGE TEMPERATURE	-40 ~ +85	C°
TERMINAL	PIN	-
INTERNAL CAPACITOR	N/A	pF

THIS DOCUMENT CONTAINS DATA PROPRIETARY TO PROJECTS UNLIMITED, INC. ANY USE OR REPRODUCTION, IN ANY FORM, WITHOUT PRIOR WRITTEN PERMISSION OF PROJECTS UNLIMITED, INC. IS PROHIBITED.
©2003, Projects Unlimited Inc.

REVISION HISTORY

LTR	DESCRIPTION	DATE	APPROVED
-	RELEASED FROM ENGINEERING	10/19/2006	
A	DELETED MOLEX CONNECTOR NOTE	7/17/2007	D.F.
B	REVISED IP RATING	7/2/2008	B.R.
C	REVISED TO INVENTOR 3-D DRAWING TEMPLATE	8/30/2008	B.R.
D	ADDED TEMPERATURES AND PIN DIAMETER	1/29/2013	B.R.

ASSEMBLY

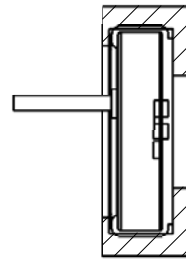
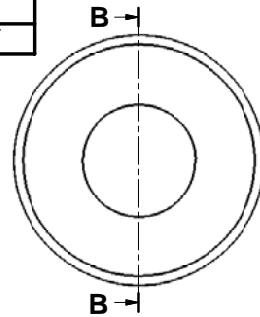

B-B (7:1)

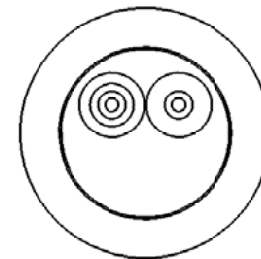

MICROPHONE

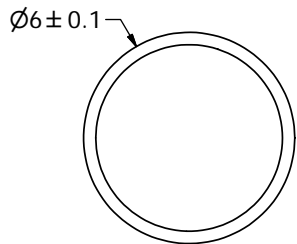

2.8 ± 0.3

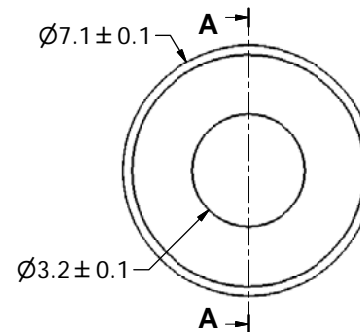
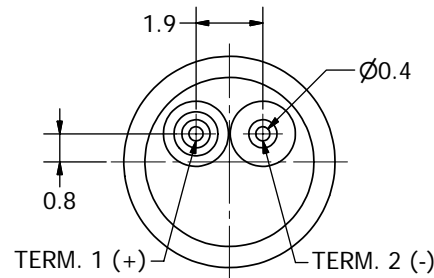
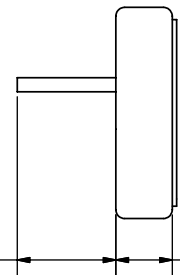

BOOT

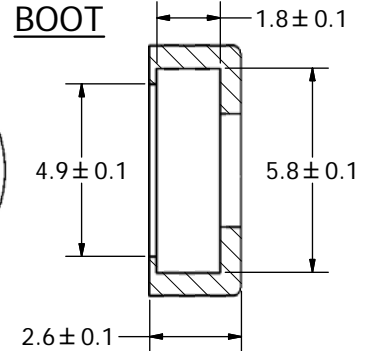

A-A (7:1)

NOTES:

1. ALL DIMENSIONS ARE IN MILLIMETERS.
2. SPECIFICATIONS SUBJECT TO CHANGE OR WITHDRAWAL WITHOUT NOTICE.
3. THIS PART IS RoHS 2002/95/EC COMPLIANT.
4. PART IS IP57 RATED.
5. ASSEMBLY IS WASHABLE WITH BOOT IN PLACE.

UNLESS OTHERWISE SPECIFIED: DIMENSIONS ARE IN MILLIMETERS, TOLERANCES ARE ±0.5 AND ANGLES ARE ±3°.	SIZE	Designed by	Date	Checked by	Date	Approved by	Date	Drawn Date	
	A3	J.D.	10/19/2006	B.R.	10/20/2006	R.W.	10/20/2006	8/30/2008	
POW-1644P-B-R.idw			POW-1644P-B-R			Microphone		Edition -	Sheet 1 / 1