

Introduction

The HAH1DR family is for the electronic measurement of DC, AC or pulsed currents in high power automotive applications with galvanic separation between the primary circuit (high power) and the secondary circuit (electronic circuit).

The HAH1DR family gives you the choice of having different current measuring ranges in the same housing (from ± 200 A up to ± 900 A).

Features

- Open Loop transducer using the Hall effect
- Unipolar + 5 V DC power supply
- Primary current measuring range ± 200 A
- Maximum RMS primary admissible current: defined by busbar to have $T^\circ < + 150$ °C
- Operating temperature range: $- 40$ °C $< T^\circ < + 125$ °C
- Output voltage: full ratio-metric (in sensitivity and offset)
- Compact design.

Advantages

- Excellent accuracy
- Very good linearity
- Very low thermal offset drift
- Very low thermal sensitivity drift
- Wide frequency bandwidth
- No insertion losses.

Automotive applications

- Battery monitoring
- Starter Generators
- Inverters
- HEV application
- EV application.

Principle of HAH1DR Family

The open loop transducers uses a Hall effect integrated circuit. The magnetic flux density B , contributing to the rise of the Hall voltage, is generated by the primary current I_p to be measured. The current to be measured I_p is supplied by a current source i.e. battery or generator (Figure 1).

Within the linear region of the hysteresis cycle, B is proportional to:

$$B(I_p) = \text{constant}(a) \times I_p$$

The Hall voltage is thus expressed by:

$$V_H = (R_H/d) \times I \times \text{constant}(a) \times I_p$$

Except for I_p , all terms of this equation are constant. Therefore:

$$V_H = \text{constant}(b) \times I_p$$

The measurement signal V_H amplified to supply the user output voltage or current.

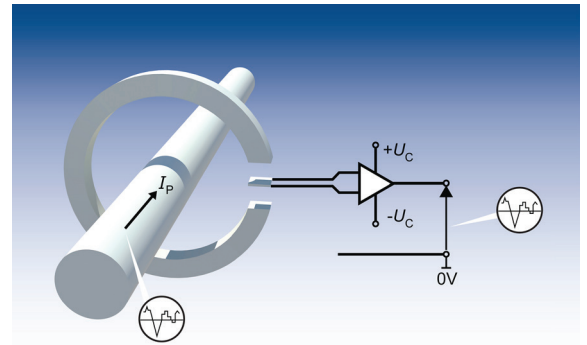
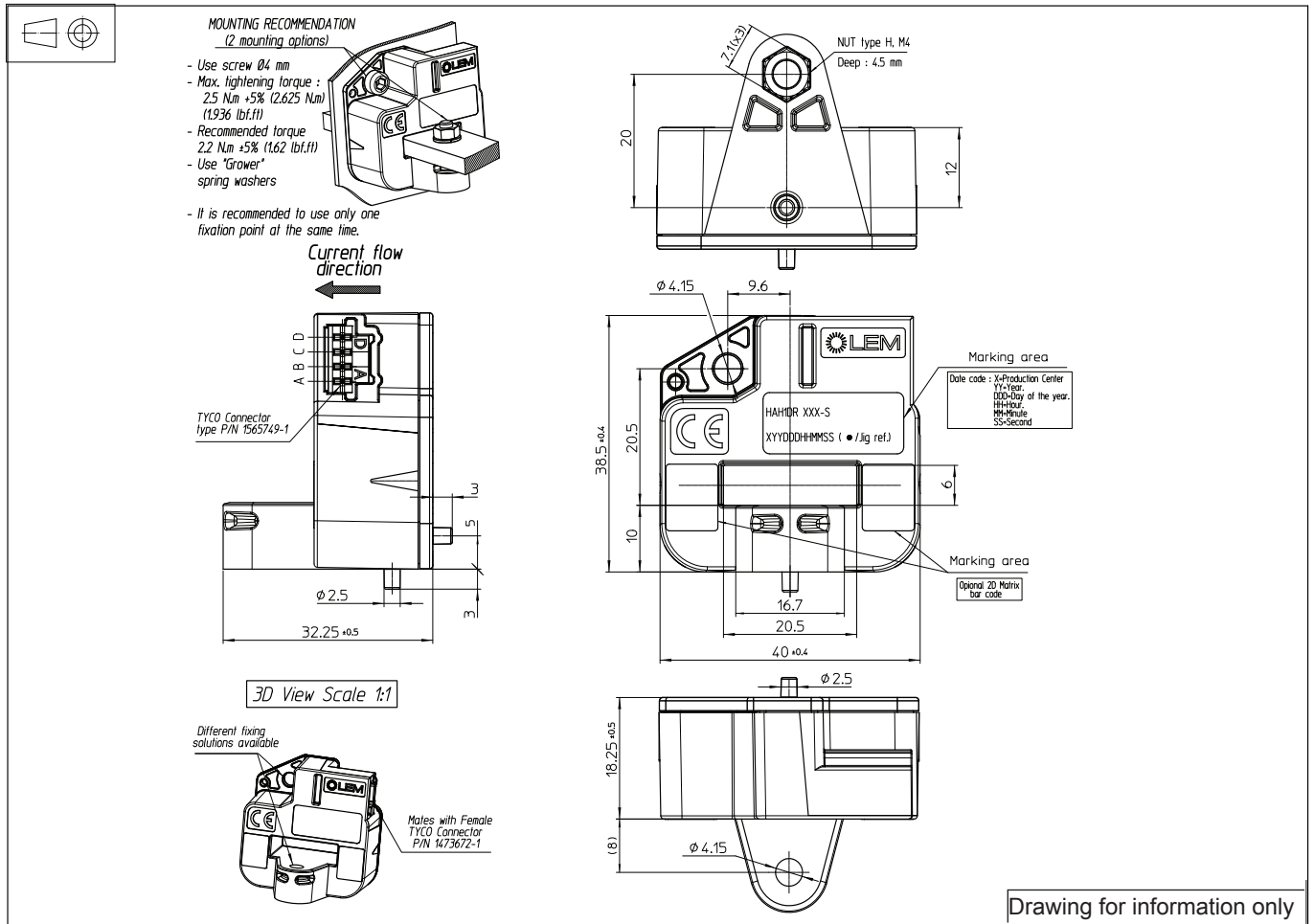

Fig. 1: Principle of the open loop transducer

Dimensions HAH1DR 200-S (in mm)



Mechanical characteristics

- Plastic case PBT GF 30
- Magnetic core Iron silicon alloy
- Mass 38 g
- Electrical terminal coating Brass tin plated

Mounting recommendation

- Connector type TYCO 1473672-1

Electronic schematic

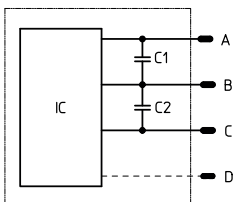

	Components list	DR version
IC	Hall sensor ASIC	
C1	Decoupling capacitor	4.7 nF
C2	Decoupling capacitor	47 nF
	Pin out	
A	V_{out}	
B	Ground	
C	U_c (5V)	
D	Not connected	

Remarks

- $V_{out} > 2.5$ when I_p flows in the direction of the arrow.

System architecture (example)

$C_L \leq 100$ nF EMC protection

RC Low pass filter EMC protection (optional)

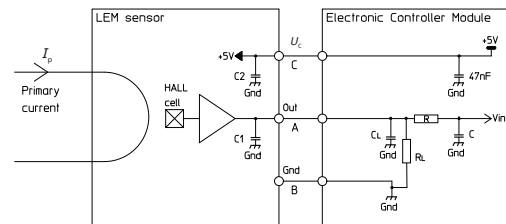

Diagnostic Mode

$R_L > 10$ k Ω optional resistor for signal line diagnostic

V_{out}	Diagnostic
Open circuit	$V_{in} = < 0.15V$
Short GND	$V_{in} = < 0.15V$

HAH1DR 200-S

Absolute Maximum ratings (not operating)

Parameter	Symbol	Unit	Specification			Conditions
			Min	Typical	Max	
Primary current peak	\hat{I}_{Pmax}				1)	
Supply continuous over voltage	U_c	V			7	Not operating
Reverse voltage 2)			- 0.5			1 min @ $T_A = 25\text{ °C}$
Ambient storage temperature	T_s	°C	- 55		125	
Electrostatic discharge voltage	U_{ESD}	kV			2	JESD 22-A114-B (HBM)
Continuous output current	I_{out}	mA	- 10		10	
RMS voltage for AC insulation test, 50 Hz, 1 min	U_d	kV			2	50 Hz, 1 min
Continuous output over voltage (Analog)	V_{out}	V	- 0.5		$U_c + 0.5$	
Insulation resistance	R_{IS}	MΩ	500			500 V - ISO 16750-2
Output Short circuit duration	t_c	minutes			2	

Operating characteristics in nominal range (I_{PN})

Parameter	Symbol	Unit	Specification			Conditions
			Min	Typical	Max	
Electrical Data						
Primary current	I_{Pn}	A	- 200		200	
Supply voltage	U_c	V	4.75	5	5.25	
Ambient operating temperature	T_A	°C	- 40		125	Connector limited 105 °C
Output voltage (Analog) 3)	V_{out}	V	$V_{out} = (U_c/5) \cdot (V_o + G \cdot I_p)$			@ U_c
Sensitivity 3)	G	mV/A		10		@ $U_c = 5\text{ V}$
Current consumption	I_c	mA		15	20	@ $U_c = 5\text{ V}$, - 40 °C < T_A < 125 °C
Load resistance	R_L	KΩ	10			
Capacitive loading	C_L	nF	1		100	
Output internal resistance	R_{out}	Ω			10	DC to 1 kHz
Ratiometricity error	ϵ_r	%		0.5		
Performance data						
Sensitivity error	ϵ_G	%	- 1	± 0.5	1	@ $T_A = 25\text{ °C}$, @ $I = I_p$
Electrical offset current	I_{OE}	A		± 0.6		@ $T_A = 25\text{ °C}$, @ $U_c = 5\text{ V}$
Magnetic offset current	I_{OM}			± 0.9		@ $T_A = 25\text{ °C}$, @ $U_c = 5\text{ V}$, after ± I_p
Global offset current	I_O		- 1.5		1.5	@ $T_A = 25\text{ °C}$
Average temperature coefficient of V_{OE}	TCI_{OEAV}	mV/°C	- 0.08	± 0.03	0.08	@ - 40 °C < T_A < 125 °C
Average temperature coefficient of G	TCG_{AV}	%/°C	- 0.035	± 0.02	0.035	@ - 40 °C < T_A < 125 °C
Linearity error	ϵ_L	%	- 1		1	@ $U_c = 5\text{ V}$, @ $T_A = 25\text{ °C}$, @ $I = I_p$
Step response time to 90 % I_{PN}	t_t	µs		6	10	@ $dI/dt = 100\text{ A/µs}$
Frequency bandwidth 4)	BW	kHz		30		@ - 3 dB
Output clamping voltage minimum	V_{SZ}	V			0.1	@ $U_c = 5\text{ V}$, @ $T_A = 25\text{ °C}$
Output clamping voltage maximum			4.9		@ $U_c = 5\text{ V}$, @ $T_A = 25\text{ °C}$	
Output voltage noise peak-peak	$V_{no p-p}$	mV			22	DC to 1 kHz

- Notes:**
- 1) Busbar temperature must be below 150 °C
 - 2) Transducer not protected against reverse polarity
 - 3) The output voltage V_{out} is fully ratiometric: The offset and sensitivity are dependent on the supply voltage U_c relative to the following formula:

$$I_p = \left(\frac{5}{U_c} \cdot V_{out} - V_o \right) \cdot \frac{1}{G} \text{ with } G \text{ in (V/A)}$$

- 4) Tested only with small signal only to avoid excessive heating of the magnetic core.

HAH1DR 200-S

HAH1DR 200 Sensitivity Error (%)

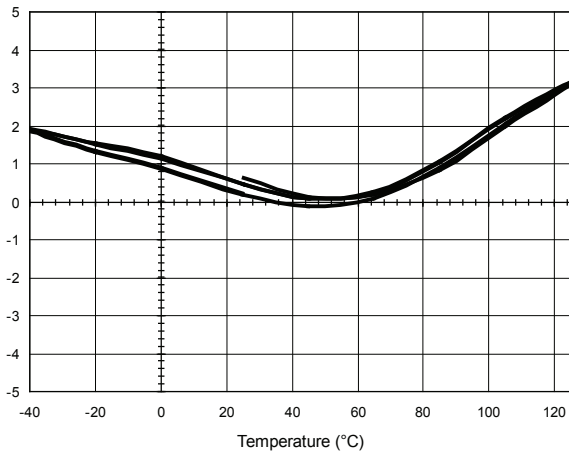

HAH1DR 200 Electrical offset Error (A)

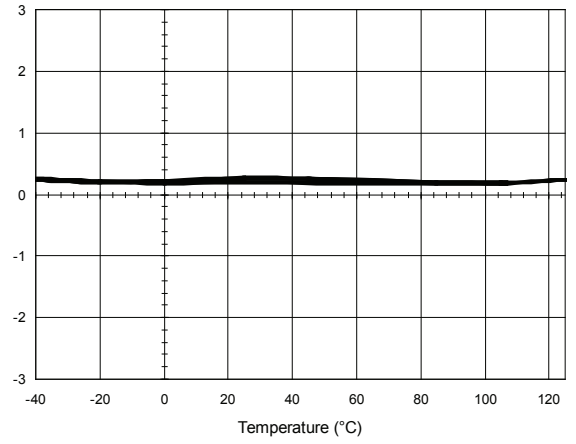

HAH1DR 200 Frequency Bandwidth

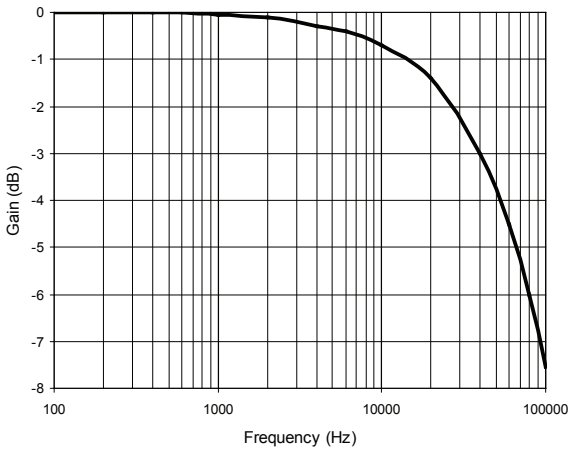

HAH1DR 200 Phase

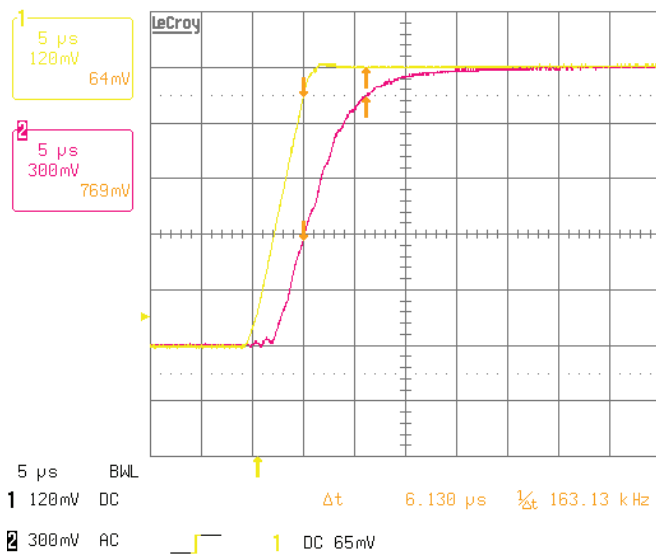
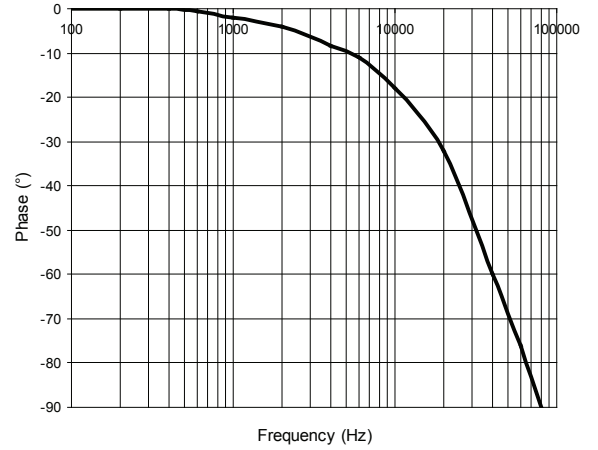

Output noise voltage:

The output voltage noise is the result of the noise floor of the Hall elements and the linear amplifier.

Magnetic offset:

The magnetic offset is the consequence of an over-current on the primary side. It's defined after an excursion of I_{PN} .

Linearity:

The maximum positive or negative discrepancy with a reference straight line $V_{out} = f(I_P)$.

Unit: linearity (%) expressed with full scale of I_{PN} .

Response time (delay time) t_r :

The time between the primary current signal (I_{PN}) and the output signal reach at 90 % of its final value.

Sensitivity:

The Transducer's sensitivity G is the slope of the straight line

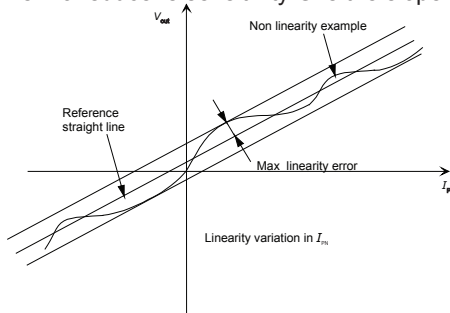

$V_{out} = f(I_P)$, it must establish the relation:

$$V_{out}(I_P) = U_C/5 (G \cdot I_P + V_o)$$

Offset with temperature:

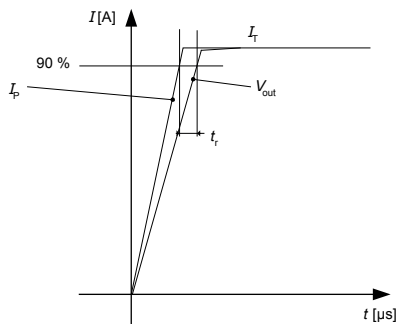

The error of the offset in the operating temperature is the variation of the offset in the temperature considered with the initial offset at 25 °C.

The offset variation I_{OT} is a maximum variation the offset in the temperature range:

$$I_{OT} = I_{OE} \max - I_{OE} \min$$

The Offset drift TCI_{OEAV} is the I_{OT} value divided by the temperature range.

Sensitivity with temperature:

The error of the sensitivity in the operating temperature is the relative variation of sensitivity with the temperature considered with the initial offset at 25 °C.

The sensitivity variation G_T is the maximum variation (in ppm or %) of the sensitivity in the temperature range:

$$G_T = (\text{Sensitivity max} - \text{Sensitivity min}) / \text{Sensitivity at } 25 \text{ } ^\circ\text{C}$$

The sensitivity drift TCG_{AV} is the G_T value divided by the temperature range. Deeper and detailed info available is our LEM technical sales offices (www.lem.com).

Offset voltage @ $I_p = 0$ A:

The offset voltage is the output voltage when the primary current is zero. The ideal value of V_o is $U_C/2$ at $U_C = 5$ V. So, the difference of $V_o - U_C/2$ is called the total offset voltage error. This offset error can be attributed to the electrical offset (due to the resolution of the ASIC quiescent voltage trimming), the magnetic offset, the thermal drift and the thermal hysteresis. Deeper and detailed info available is our LEM technical sales offices (www.lem.com).

Environmental test specifications:

Name	Standard	Conditions
Damp heat, steady state	JESD22-A101	85 °C - 85 °C / 1000 h
Insulation resistance	ISO 16750-2 § 4.10	500 V/1min
Temperature humidity cycle test	ISO 16750-4	- 10 + 85 °C 10 days
Isolation test	IEC 60664-1	2 kV / 50 Hz / 1min
Mechanical tests		
Vibration test (random)	IEC 60068-2-64 ISO 16750-3 & 4.1.2.5 (2007)	20 ... 2000 Hz Random rms (11g rms) 8 h / axis
Terminal strength test	According to LEM	
Thermal shocks	IEC 60068-214 Na	- 40 + 125 °C 300 cycles
Free fall	ISO 16750-3 § 4.3	1 m concrete ground
EMC Test		
Radiated electromagnetic immunity	Directive 2004/104/CE ISO 11452-2	30 V/m 20-2000 MHz
Bulk current injection immunity	Directive 2004/104/CE ISO 11452-4	1 - 400 MHz - 60 mA
Radiated radio frequency electromagnetic field immunity	IEC 61000-4-3	80 MHz to 1,000 MHz - 10 V/m
Electrostatic discharge immunity test	IEC 61000-4-2	Air discharge=2 kV