

111-INSIDER-P / 231-INSIDER-P

Single-Phase Pump Monitor



Description

The Littelfuse 111-Insider-P single-phase products fit inside 1/3 and 1/2, 115V control boxes and the 231-Insider-P fits inside 1/3, 1/2, 3/4, and 1 hp, 230V control boxes. Both models are designed to protect single-phase pumps from dry-well, dead-head, jammed impeller, rapid-cycle, overvoltage, and undervoltage conditions.

A calibration adjustment allows the Insider to be calibrated to your specific pumping applications, thereby reducing the possibility of false or nuisance tripping. A unique microcontroller-based voltage and current-sensing circuit constantly monitors the incoming power for fluctuations, overcurrent, and undercurrent. When an abnormality, such as loss of suction is detected, the product deactivates its output relay and directly disconnects the pump motor. The relay then begins its user-selectable restart delay (dry-well recovery) timer. When the timer counts to zero or power is removed and reapplied, the relay reactivates its output relay and turns the pump back on. By leaving the restart delay knob in the reset position, the relay will operate in manual reset mode.

The Insider communicates with a hand-held diagnostics tool called the Informer (sold separately). The Informer displays parameters including calibration points, trip points, run time and last faults. An IR Kit-12 (12" fiber optic kit) is included with each Insider, allowing the Informer to access these parameters even when the Insider is enclosed in a control box. This is valuable for troubleshooting the pump while it is running.

NOTE: The 111/231-Insider-P models have a sensitivity adjustment for the dry-well trip point. After calibration is done, you can adjust the sensitivity for the dry-well/dead-head trip point from 70-90% of the full load. This makes the unit even more adaptable to varying pumping applications. If you have a very low producing well, you increase the sensitivity closer to the 90% mark, or if you have a very heavy producing well, you would decrease the sensitivity around the 70% mark.

Wiring Diagrams

See next page.

Accessories



Informer

A hand-held diagnostic tool that uses an infrared receiver to access information which can be helpful for troubleshooting the system. Includes the Informer IR Kit-12



Informer IR Kit-12

12" infrared adapter cable attaches to the face of the unit to provide remote diagnostics without opening the panel. Included with the Informer

Ordering Information

MODEL	VOLTAGE	DESCRIPTION
111-Insider-P	115VAC	1/3 - 1/2 hp, includes IR Kit-12
231-Insider-P	230VAC	1/3 - 1 hp, includes IR Kit-12

Features & Benefits

FEATURES	BENEFITS
Proprietary microcontroller based circuitry	Constant monitoring of voltage and current protects pumps from dry-well, dead-head, jammed impeller, rapid cycling, and voltage faults
Onboard calibration adjustment	Allows user to adjust the current sensitivity for the dry-well / dead-head trip point from 70% - 90% of the full load.
Adjustable restart delay	Allows user to select well recovery time delay after a dry-well condition occurs, or to select manual reset
Built in IR communications link	Used with the Informer, allows user to see stored faults, run time, and also troubleshoot the pump while it's running
LED indication	Provides status and diagnostics for troubleshooting

111-INSIDER-P / 231-INSIDER-P

Specifications

Functional Specifications

Adjustments/Settings

Overcurrent	125% of calibration point
Underload (dry-well)	Adjustable (70 to 90% of calibrated run power)
Overvoltage	
111-Insider-P	132.5VAC
231-Insider-P	265VAC
Undervoltage	
111-Insider-P	95VAC
231-Insider-P	190VAC
Number of restarts allowed in a 60-sec. period (rapid-cycling)	4
Trip Delay Times	
Overcurrent	5 seconds
Dry-well	4 seconds
Restart Delay Times	
Over/Undervoltage	2 seconds
All other faults	Manual, 2-225 minutes

Input Characteristics

Supply Voltage	
111-Insider-P	115VAC
231-Insider-P	230VAC
Load Range	
111-Insider-P	1/3 – 1/2 hp
231-Insider-P	1/3 – 1 hp
Frequency	50/60Hz <i>(Note: 50Hz will increase all delay timers by 20%)</i>

Output Characteristics

Output Contact Rating-SPST	
111-Insider-P	1/2hp@120VAC (17 amps max.)
231-Insider-P	1hp@ 240VAC (17 amps max.)

General Characteristics

Operating Temperature	-40° to 55° C (-40° to 131° F)
Maximum Input Power	5 W
Safety Marks	
cUR*	UL508, C22.2 No. 14
Weight	10 oz.
Mounting Methods	Inside a Pentek®, Franklin™, CentriPro™, Grundfos®, and Flint and Walling™ control box

**The 111-Insider-P and 231-Insider-P are approved by UL for use in the Franklin™, Pentek®, and CentriPro™ type 3R control boxes when installed as described in the installation instructions. The 111-Insider-P and 231-Insider-P are not intended to provide overload protection, and should be used with thermally or impedance protected motors only.*

Wiring Diagrams

PENTEK® CONTROL BOX WIRING DIAGRAM

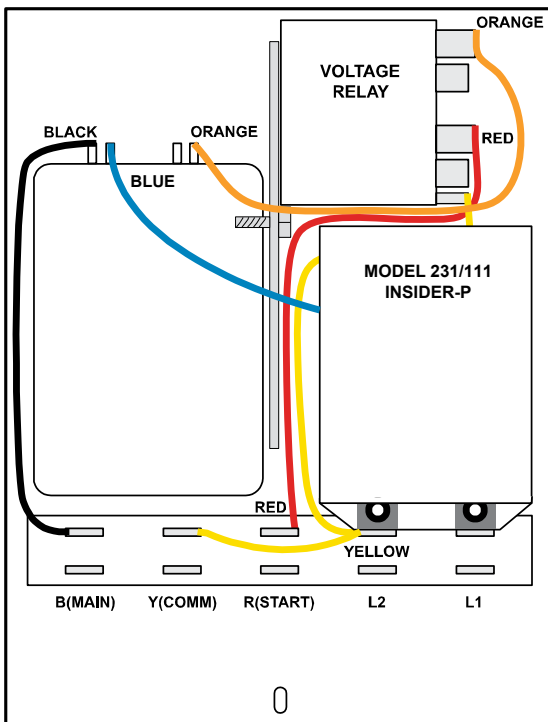

FRANKLIN™ CONTROL BOX WIRING DIAGRAM

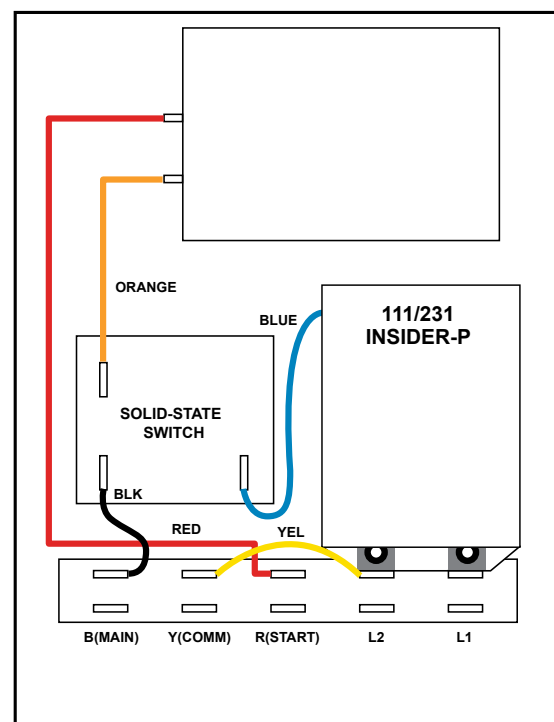

111-INSIDER-P / 231-INSIDER-P

CENTRIPRO™ CONTROL BOX WIRING DIAGRAM

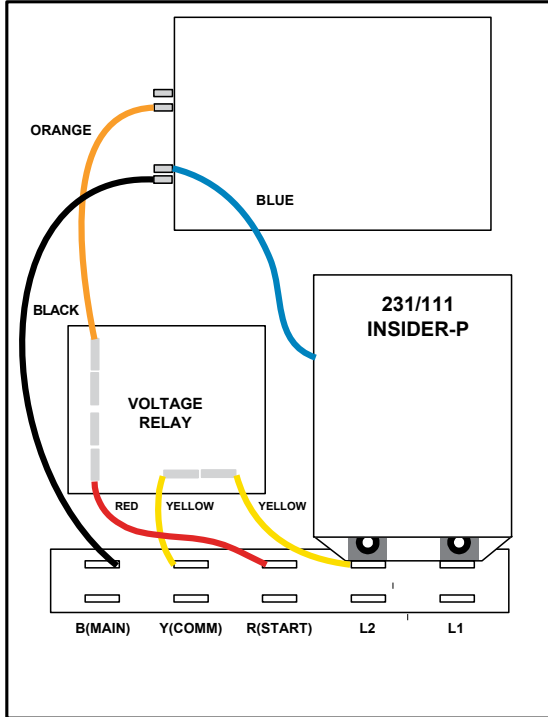

FLINT AND WALLING™ CONTROL BOX WIRING DIAGRAM

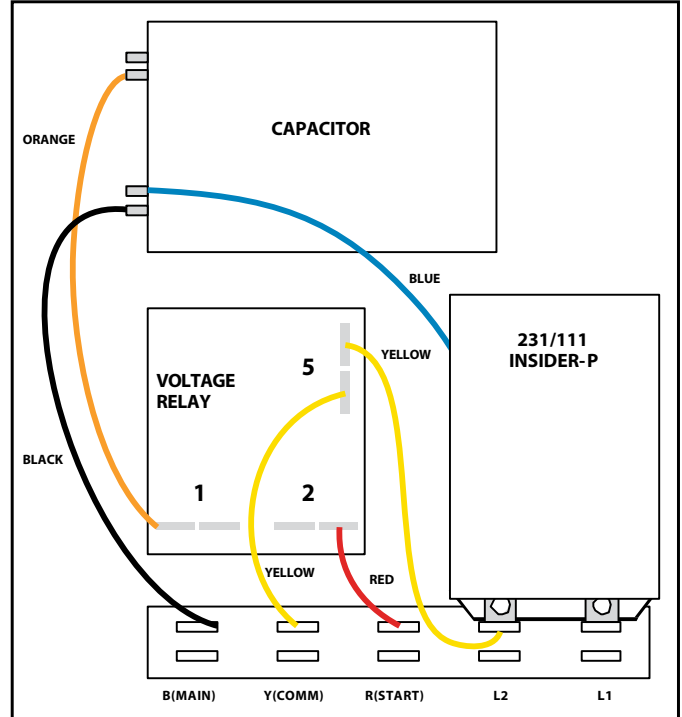

GRUNDFOS® CONTROL BOX WIRING DIAGRAM

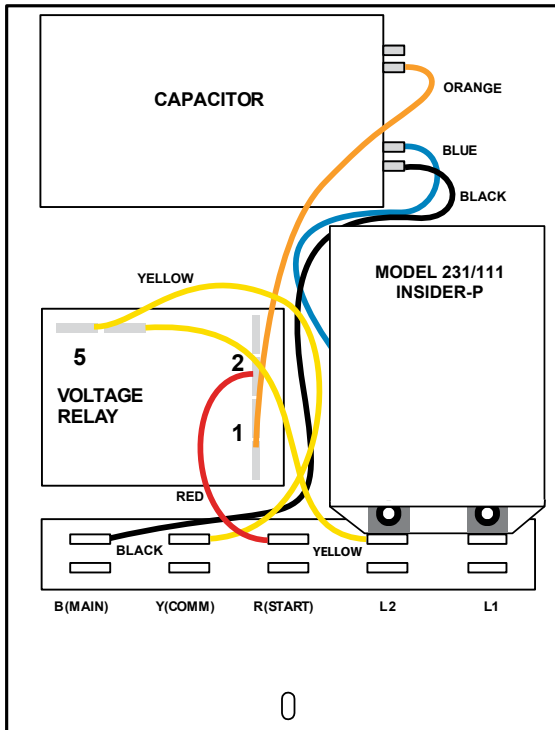

For installation instructions see the [Fresh Water Pumping Catalog](#).