

HF
Halogen Free

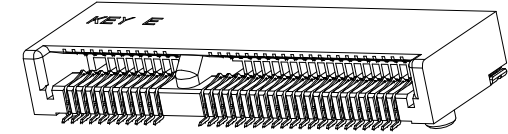
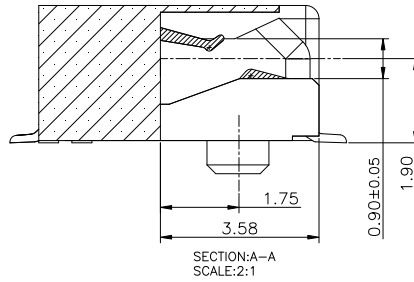
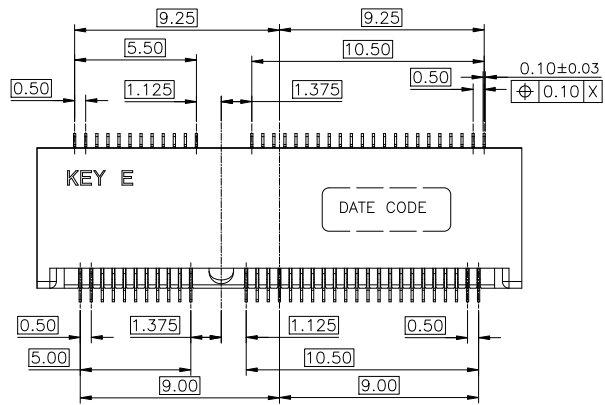

NOTES:

- MATERIAL:
 - HOUSING:HIGH TEMPERATURE THERMOPLASTIC,UL94V-0,COLOR:BLACK.
 - CONTACT:COPPER ALLOY.
 - SOLDER PEG:STAINLESS STEEL.
- FINISH:
 - CONTACT:
 - UNDERPLATING NICKEL 50u" MIN OVERALL
 - MATING AREA:GOLD PLATING,THICKNESS SEE TABLE
 - SOLDER AREA:GOLD FLASH 1u" MIN.
 - SOLDER PEG:
 - UNDERPLATING NICKEL 50u" MIN OVERALL
 - 80u"MIN MATTE TIN ON SURFACE
- DATE CODE : YYWWDLX
 - YY: YEAR (09: 2009)
 - WW: WEEK (25: THE 25TH WEEK)
 - D: DAY (1~7: SUNDAY~SATURDAY)
 - L: LINE NUMBER OF ASSEMBLY (A: LINE A)
 - X: D OR N (D: DAY; N: NIGHT)
- PRODUCT SPECIFICATION SEE FCI GS-12-1195
- PART NUMBER DESCRIPTION:
 - 10128788-00XRLF

LF:LEAD FREE & RoHS COMPLIANCE

PACKAGE CODE:

R: TAPE & REEL PACKING

PLATING CODE:

1: GOLD FLASH ON CONTACT AREA

4: 15u"Min GOLD ON CONTACT AREA

5: 30u"Min GOLD ON CONTACT AREA

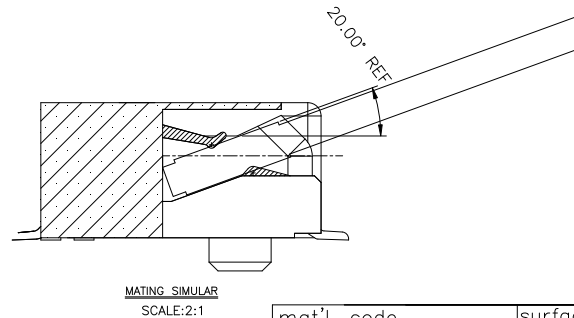
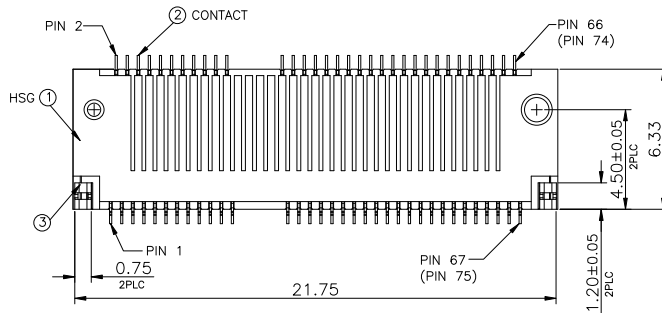
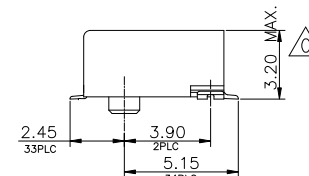
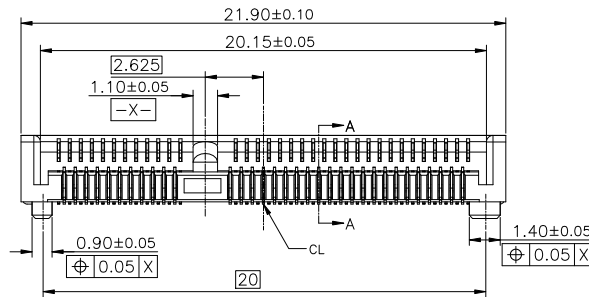

mat'l. code		surface	tolerance	projection	product family
ltr	ecn no	dr	date	tolerances unless otherwise specified	title M.2 CONNECTOR 3.2H_STD_KEY E
A		BF	2013-04-18	angles	
B	ELX-T-19318	TAI	2014-11-10	trial	
C	ELX-T-20858	TAI	2015-05-11	X*±2"	scale
		dr	BEER FU	2013-05-02	dwg no 10128788 sheet 1 of 3 size A4 type Customer Drawing
		enrg	BEER FU	2013-05-02	
		chr	BEER FU	2013-05-02	
		appd	BEER FU	2013-05-02	
sheet index	revision sheet	C	C	C	
		1	2	3	

30u" Au	10128788-005RLF
15u" Au	10128788-004RLF
GOLD FLASH	10128788-001RLF
CONTACT AREA	FCI P/N

HF
Halogen Free



PLUG PCB

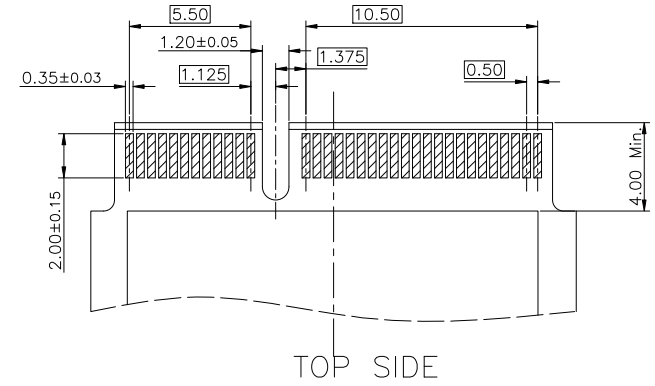
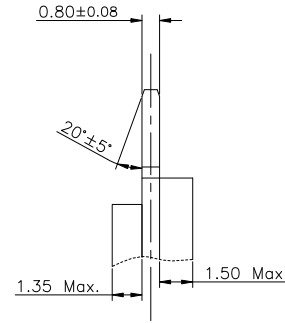
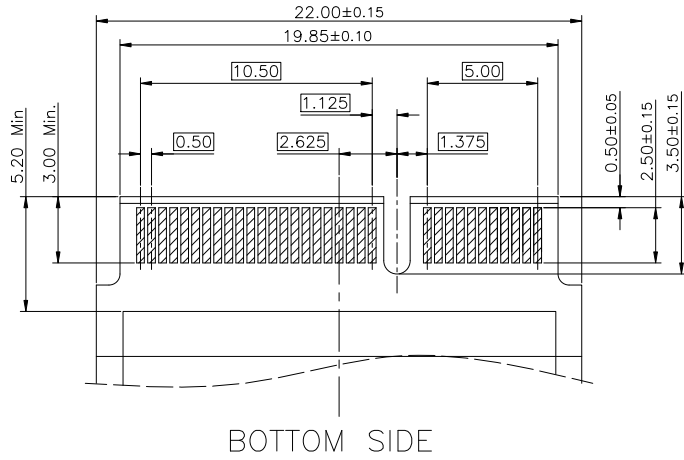

RECOMMENED M.2(NGFF) MINI CARD MOUNTING TYP PCB_LAYOUT

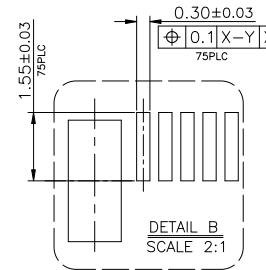
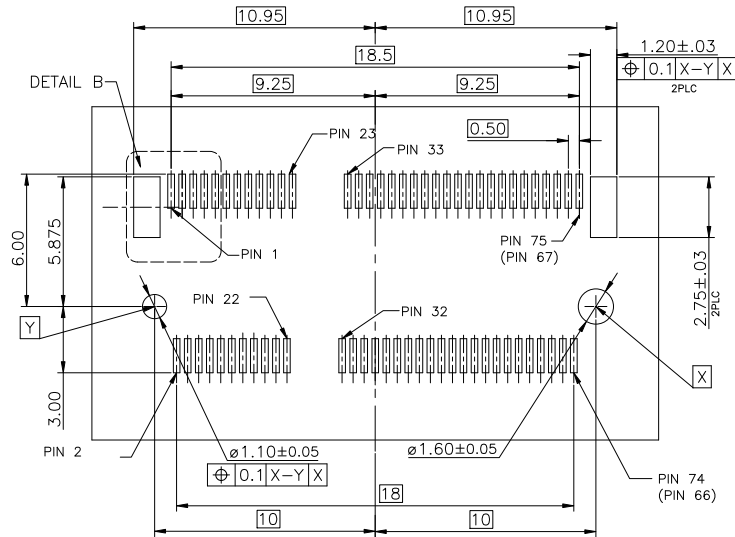

dwg no	sheet 2 of 3	size
10128788		A4
type	Customer Drawing	

sheet index	revision sheet	C	C	C													
	1	2	3														

HF
Halogen Free



FEEDING DIRECTION

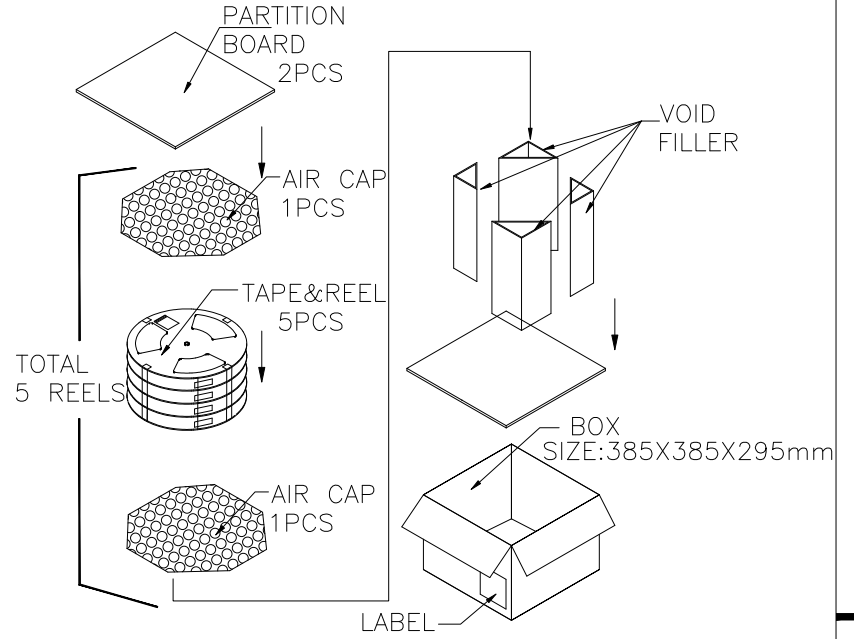
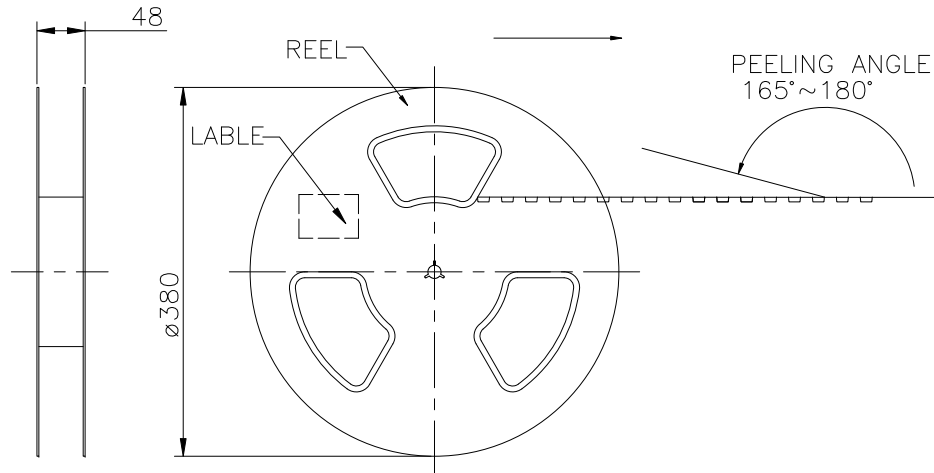

A

A

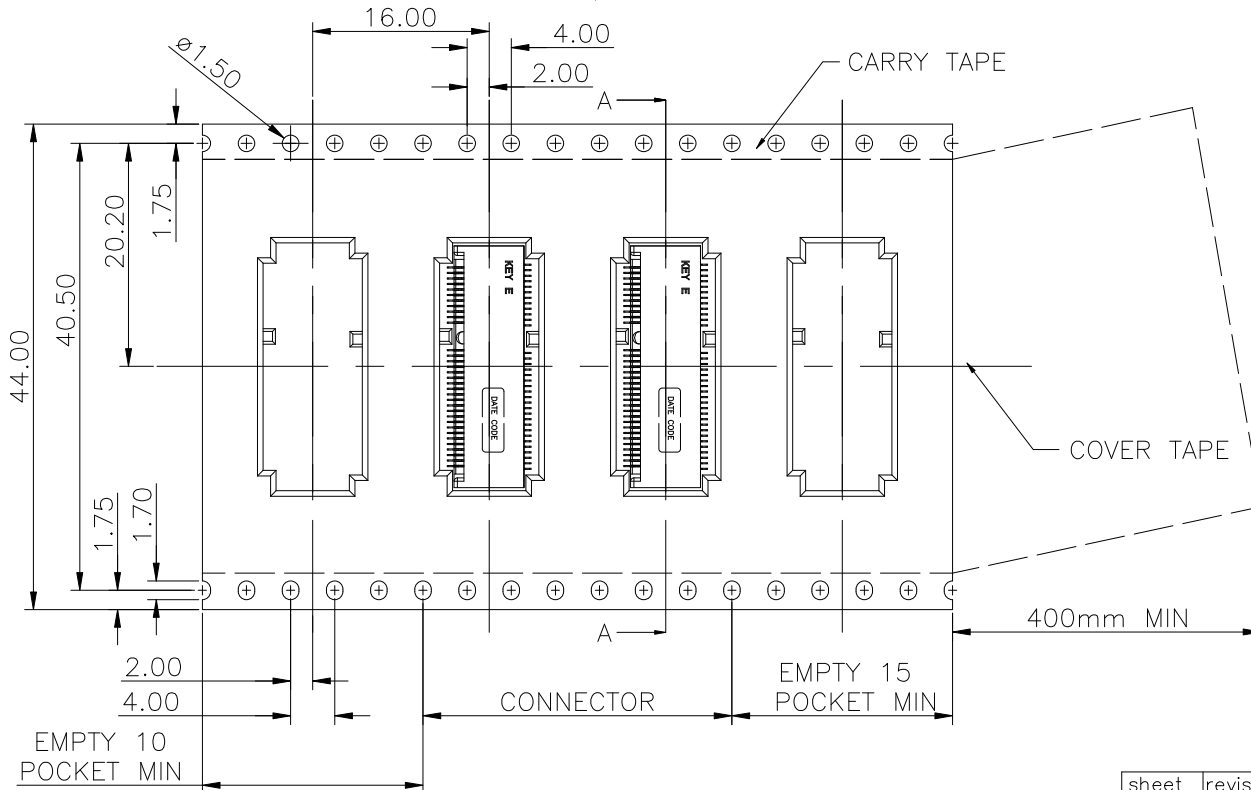

1400	5	7000	7.85Kg	3.5Kg
PCS/TAPE	REELS/BOX	PCS/BOX	GROSS WEIGHT	NET WEIGHT

B

B

FCI dwg no 10128788 sheet 3 of 3 size A4
type Customer Drawing

sheet index	revision sheet	C 1	C 2	C 3																
-------------	----------------	-----	-----	-----	--	--	--	--	--	--	--	--	--	--	--	--	--	--	--	--