

© 1967 BY AMP INCORPORATED. ALL RIGHTS RESERVED. AMP PRODUCTS COVERED BY PATENTS AND/OR PATENTS PENDING.

REVISIONS				
ZONE	LTR	DESCRIPTION	DATE	APPROVED
	B	REDRAWN { REV P.6077	7-30-69	FCY
	C	REVISED PC-5579	10-8-70	Jme
	D	REV, & ADDED TAPE NO'S PC-5578	7-6-71	FCY
	E	REVISED PC-5578	2-23-77	L.D
	F	<del>OBSOLETE 50837-24-3/G-0965</del>	4/22/87	GS Jgm
	G	<del>OBSOLETE -1 PER G-2972</del>	8/22/88	JW
	H	REV/ 0610-0094-98	2-5-99	ME/MS
	H1	REV PER SCR 05-013140	10/20/05	DL/Tm

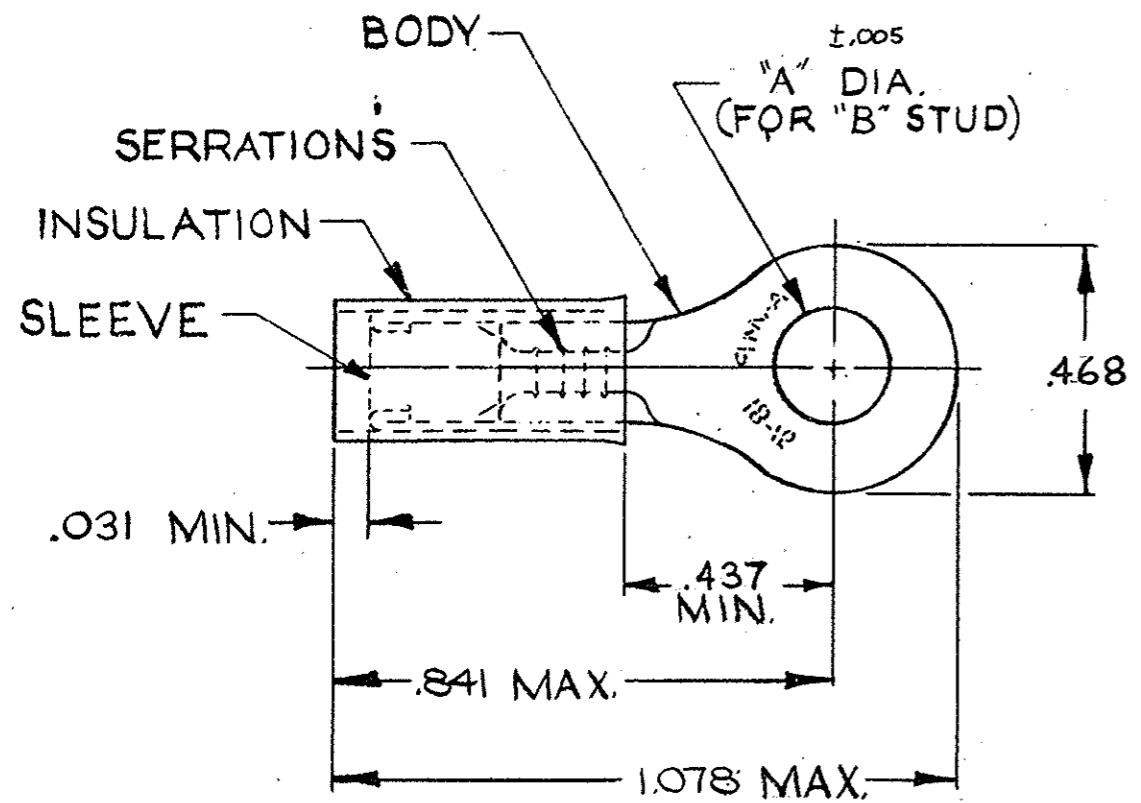

FOR .055 TO .135 WIRE INSULATION DIA.  
TONGUE MATERIAL THK = .031 ±.002

TABLE I

1	WIRE TERMINAL	SEE TABLE II	BODY: COPPER (ASTM B152) NICKEL PLATE (QQ-N-290) .0003 AVG. EXT. THK.
			SLEEVE: COPPER (ASTM B152) NICKEL PL (QQ-N-290). 00003 AVG. EXT. THK.
			INSULATION: TEFLON (ASTM D3295) COLOR: ORANGE
QTY	DESCRIPTION	PART NO.	MATERIAL & FINISH
UNLESS OTHERWISE SPECIFIED, DIMENSIONS ARE IN INCHES TOLERANCES ON: DECIMALS ±.008 ANGLES ± 5°			CONTRACT NO. H
MATERIAL			AMP INCORPORATED HARRISBURG, PENNSYLVANIA
SEE TABLE I			NAME WIRE TERMINAL PIDG - STRATO-THERM - RING TONGUE WIRE SIZE: 18-16
			DR. Steve Kautz 7-24-69
			CHK. H.C. Young 7-30-69
			APPD. Swabel 8-6-69
			REL. M. Eversinger 8-6-69
			DSGN APPD.
			OTHER APPD.
		SIZE	CODE IDENT NO. NUMBER
		B	00779 50837
		SCALE	SHEET
		NTS	10F1

TABLE II

<del>50837</del>	.328	5/16	<del>50837-3</del>	OBSOLETE
50837	.265	1/4	<del>50837-2</del>	OBSOLETE
PART NO.	"A"	"B"	PART NO. ON TAPE	