

Fig.2(1:1)

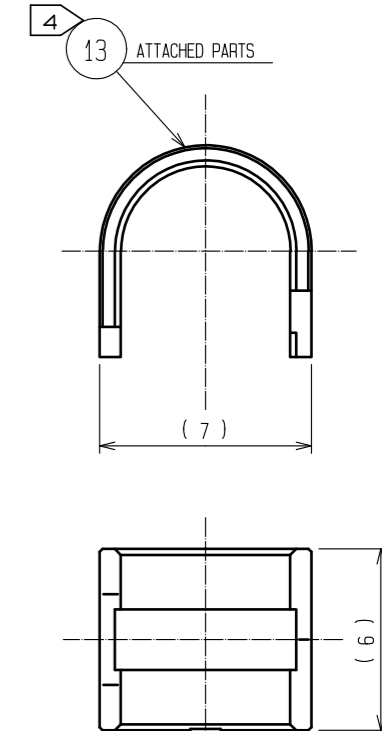
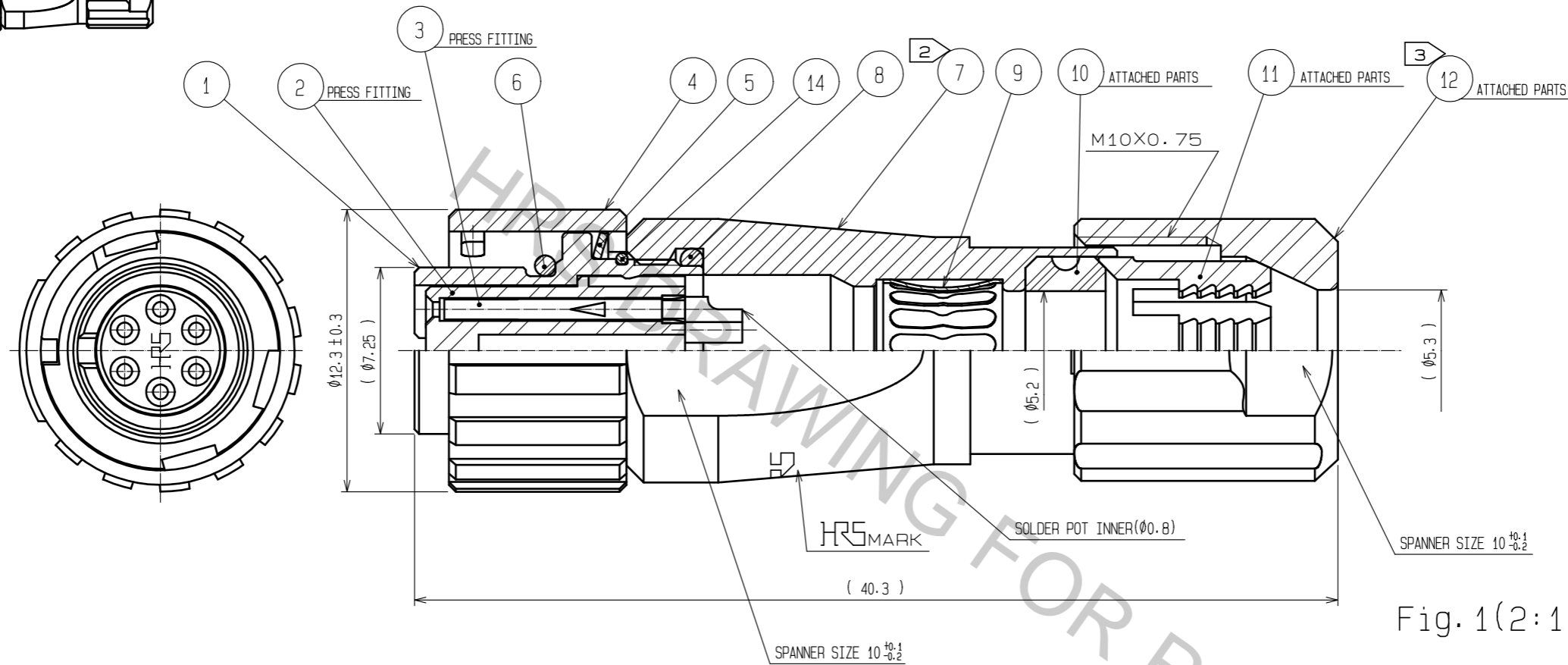
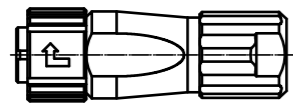
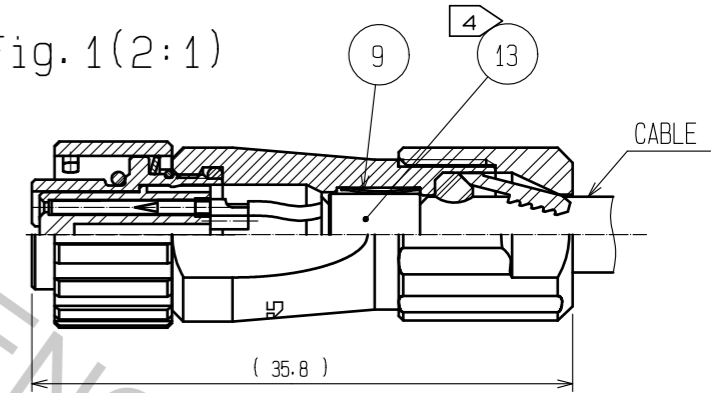

Fig. 1(2:1)



- NOTES
- ① PLATING(REF.NO. ③)
 CONTACT AREA : GOLD 0.2μm min
 OTHERS : GOLD AND NICKEL
 UNDER PLATING : NICKEL 2μm min
 - ② THE RECOMMENDED CLAMP TORQUE OF REF.NO. ⑦ TO BE 1 TO 1.5N·m.
 THREAD LOCKER TO THE THREADED PORTION OF REF.NO. ① IS RECOMMENDED TO PREVENT REF.NO. ⑦ FROM LOOSING.
 RECOMMENDED THREAD LOCKER:LOCTITE 263, HENKEL JAPAN LTD.
 - ③ THE RECOMMENDED CLAMP TORQUE OF REF.NO. ⑫ TO BE 0.8 TO 1N·m.
 THREAD LOCKER AND LOCK PRIMER TO THE THREADED PORTION M10X0.75 OF REF.NO. ⑦ IS RECOMMENDED
 TO PREVENT REF.NO. ⑫ FROM LOOSING.
 RECOMMENDED THREAD LOCKER AND LOCK PRIMER : LOCTITE 263, LOCK PRIMER 7649, HENKEL JAPAN LTD.
 - ④ FASTEN REF.NO. ⑬ TO THE CABLE WITH THE CABLE CRIMPING TOOL.
 AND MAKE REF.NO. ⑬ CONTACT WITH REF.NO. ⑨ (REFER TO Fig.1).
 REFER TO THE TECHNICAL SPECIFICATION ETAD-C0099 FOR DETAILS.
 APPLICABLE CABLE CRIMPING TOOL : HR10A-TC-02(CL150-0041-2)(THE HOLE DIAMETER FOR CRIMPING:Ø5.3)
 - ⑤ Fig.2 SHOWS THE APPEARANCE AFTER ASSEMBLY.
 - ⑥ APPLICABLE CABLE ASSEMBLY FIXTURE : LF07BP-T01(CL150-0232-0)
 CABLE ASSEMBLY FIXTURE IS USED AS A RECEPTACLE STAND OF EXTRACT
 AND THE PART No. ① OF AN ASSEMBLY.
 - ⑦ ROTATION EXAMPLES OF No. ④, ⑦ AND ⑫ TO ① ARE SHOWN.

NO.	MATERIAL	FINISH . REMARKS	NO.	MATERIAL	FINISH . REMARKS
7	ZINC ALLOY	NICKEL PLATING	14	STAINLESS STEEL	
6	CHLOROPRENE RUBBER	(BLACK)	13	BRASS	NICKEL PLATING
5	STAINLESS STEEL		12	PPS	(NATURAL, BROWN) UL94V-0
4	ZINC ALLOY	NICKEL PLATING	11	POLYAMIDE	(NATURAL, MILKY WHITE) UL94V-0
3	PHOSPHOR BRONZE	①	10	CHLOROPRENE RUBBER	(BLACK)
2	PPS	(BLACK) UL94V-0	9	PHOSPHOR BRONZE	NICKEL PLATING
1	ZINC ALLOY	NICKEL PLATING	8	CHLOROPRENE RUBBER	(BLACK)
NO.	MATERIAL	FINISH . REMARKS	NO.	MATERIAL	FINISH . REMARKS

UNITS	SCALE	COUNT	DESCRIPTION OF REVISIONS	DESIGNED	CHECKED	DATE
mm	4 : 1	△				
APPROVED : HY. KOBAYASHI			18.02.22	DRAWING NO. EDC-113835-31-00		
CHECKED : HY. KOBAYASHI			18.02.22	PART NO. LF07WBP-6S(31)		
DESIGNED : TY. SUZUKI			18.02.22	CODE NO. CL136-0001-1-31		
DRAWN : TY. SUZUKI			18.02.22			