

EVALUATION KIT  
AVAILABLE

# Automotive 300mA LDO Voltage Regulators with Tracker Output and Overvoltage Protector

## General Description

The MAX15008 features a 300mA LDO regulator, a voltage tracker, and an overvoltage protection (OVP) controller to protect downstream circuits from high-voltage load dump. The MAX15010 includes only the 300mA LDO voltage regulator and voltage tracker. Both devices operate over a wide 5V to 40V supply voltage range and are able to withstand load-dump transients up to 45V. The MAX15008/MAX15010 feature short-circuit and thermal-shutdown protection. These devices offer highly integrated power-management solutions for automotive applications such as instrument clusters, climate control, and a variety of automotive power-supply circuits.

The 300mA LDO regulator consumes less than 67 $\mu$ A quiescent current at light loads and is well suited to power always-on circuits during “key off” conditions. The LDO features independent enable and hold inputs as well as a microprocessor ( $\mu$ P) reset output with an adjustable reset timeout period.

The voltage tracker accurately ( $\pm$ 3mV) tracks a voltage applied to its input from either the LDO output or an external source. It can supply up to 50mA of current to a remote sensor, allowing for precise ratiometric tracking in automotive applications. A separate enable input turns the tracker on or off, reducing supply current when the tracker is unused. The voltage tracker also features protection against battery reversal, an output short circuit to the battery, or an output-voltage excursion below ground potential to as much as -5V.

The MAX15008 OVP controller operates with an external enhancement mode n-channel MOSFET. While the monitored voltage remains below the adjustable threshold, the MOSFET stays on. When the monitored voltage exceeds the OVP threshold, the OVP controller quickly turns off the external MOSFET. The OVP controller is configurable as a load-disconnect switch or a voltage limiter.

The MAX15008/MAX15010 are available in a thermally enhanced, 32-pin (5mm x 5mm) TQFN package and are fully specified over the -40°C to +125°C automotive operating temperature range.

## Applications

- Instrument Clusters
- Climate Control
- AM/FM Radio Power Supply
- Multimedia Power Supply
- Telematics Power Supply

Typical Operating Circuits appear at end of data sheet.

## Features

- ◆ 300mA LDO Regulator, Voltage Tracker, and OVP Controller (MAX15008)
- ◆ 300mA LDO Regulator and Voltage Tracker (MAX15010)
- ◆ 50mA Voltage Tracker with  $\pm$ 3mV Tracking Accuracy
- ◆ 5V to 40V Wide Operating Supply Voltage Range
- ◆ 45V Load Dump Protection
- ◆ 67 $\mu$ A Quiescent Current LDO Regulator
- ◆ OVP Controller Disconnects or Limits Output from Battery Overvoltage Conditions (MAX15008)
- ◆ LDO Regulator with Enable, Hold, and Reset Features

## Ordering Information

PART	TEMP RANGE	PIN-PACKAGE	PKG CODE
MAX15008ATJ+	-40°C to +125°C	32 TQFN-EP*	T3255-4
MAX15010ATJ+	-40°C to +125°C	32 TQFN-EP*	T3255-4

+Denotes a lead-free package.

\*EP = Exposed pad.

## Selector Guide

PART	LDO	TRACKER	OVP CONTROLLER
MAX15008	√	√	√
MAX15010	√	√	—

## Pin Configurations

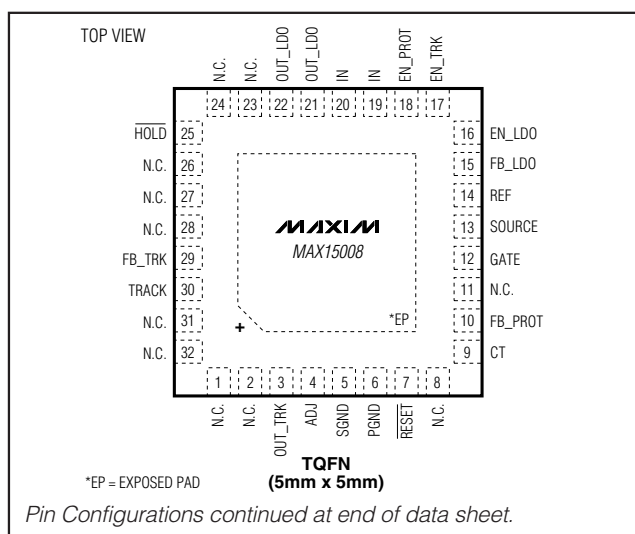

MAX15008/MAX15010

# Automotive 300mA LDO Voltage Regulators with Tracker Output and Overvoltage Protector

## ABSOLUTE MAXIMUM RATINGS

(All pins referenced to SGND, unless otherwise noted.)

IN, GATE	-0.3V to +45V
TRACK	-20V to +45V
EN_LDO, EN_PROT, EN_TRK	-0.3V to (V <sub>IN</sub> + 0.3V)
SOURCE	-0.3V to (V <sub>IN</sub> + 0.3V)
TRACK to OUT_TRK	-40V to +40V
OUT_TRK, FB_TRK, ADJ	-5V to +45V
OUT_LDO, FB_LDO, FB_PROT, RESET	-0.3V to +12V
GATE to SOURCE	-0.3V to +12V
HOLD	-0.3V to (V <sub>OUT_LDO</sub> + 0.3V)
REF to SGND	-0.3V to +6V
CT to SGND	-0.3V to +12V
SGND to PGND	-0.3V to +0.3V

IN, OUT_LDO Current	700mA
TRACK, OUT_TRK Current	350mA
Current Sink/Source (all remaining pins)	50mA
Continuous Power Dissipation (T <sub>A</sub> = +70°C)	
32-Pin TQFN (derate 34.5mW/°C above +70°C)	2.7W*
Thermal Resistance	
θ <sub>JA</sub>	29.0°C/W
θ <sub>JC</sub>	1.7°C/W
Operating Temperature Range	-40°C to +125°C
Junction Temperature	+150°C
Storage Temperature Range	-60°C to +150°C
Lead Temperature (soldering, 10s)	+300°C

\*As per JEDEC51 Standard, Multilayer Board (PCB).

Stresses beyond those listed under "Absolute Maximum Ratings" may cause permanent damage to the device. These are stress ratings only, and functional operation of the device at these or any other conditions beyond those indicated in the operational sections of the specifications is not implied. Exposure to absolute maximum rating conditions for extended periods may affect device reliability.

## ELECTRICAL CHARACTERISTICS

(V<sub>IN</sub> = V<sub>TRACK</sub> = +14V, V<sub>SGND</sub> = V<sub>PGND</sub> = 0V, C<sub>GATE</sub> = 6000pF, C<sub>IN</sub> = 10μF (ESR ≤ 1.5Ω), C<sub>OUT\_LDO</sub> = 22μF (ceramic), C<sub>TRACK</sub> = 3.3μF (ceramic) (ESR ≤ 1.5Ω), C<sub>OUT\_TRK</sub> = 10μF (ESR ≤ 1.5Ω), C<sub>REF</sub> = 1000pF, V<sub>OUT\_LDO</sub> = 5V, T<sub>A</sub> = T<sub>J</sub> = -40°C to +125°C, unless otherwise noted. Typical values are at T<sub>A</sub> = +25°C.) (Note 1)

PARAMETER	SYMBOL	CONDITIONS	MIN	TYP	MAX	UNITS
Supply Voltage Range	V <sub>IN</sub>		5		40	V
Supply Current	I <sub>IN</sub>	EN_LDO = IN, EN_TRK = EN_PROT = 0V, I <sub>OUT_LDO</sub> = 0μA, LDO on, tracker off, protector off, measured from SGND		67	85	μA
		MAX15008 EN_LDO = EN_TRK = IN, EN_PROT = 0V, LDO on, I <sub>OUT_LDO</sub> = 100μA, tracker on, I <sub>OUT_TRK</sub> = 0μA, protector off, V <sub>FB_TRK</sub> = V <sub>OUT_TRK</sub> , V <sub>ADJ</sub> = V <sub>REF</sub> , measured from SGND		120	180	
		MAX15010 EN_LDO = EN_TRK = IN, EN_PROT = IN, LDO on, I <sub>OUT_LDO</sub> = 100μA, tracker on, I <sub>OUT_TRK</sub> = 0μA, protector on, V <sub>FB_TRK</sub> = V <sub>OUT_TRK</sub> ; V <sub>ADJ</sub> = V <sub>REF</sub> , measured from SGND		190	280	
		MAX15010 EN_LDO = EN_TRK = IN, LDO on, I <sub>OUT_LDO</sub> = 100μA, tracker on, I <sub>OUT_TRK</sub> = 0μA, measured from SGND		115	160	
Shutdown Supply Current	I <sub>SHDN</sub>	EN_LDO = EN_PROT = EN_TRK = 0V, measured from SGND	T <sub>A</sub> = -40°C to +85°C	16	30	μA
			T <sub>A</sub> = -40°C to +125°C		40	

# Automotive 300mA LDO Voltage Regulators with Tracker Output and Overvoltage Protector

MAX15008/MAX15010

## ELECTRICAL CHARACTERISTICS (continued)

( $V_{IN} = V_{TRACK} = +14V$ ,  $V_{SGND} = V_{PGND} = 0V$ ,  $C_{GATE} = 6000pF$ ,  $C_{IN} = 10\mu F$  (ESR  $\leq 1.5\Omega$ ),  $C_{OUT\_LDO} = 22\mu F$  (ceramic),  $C_{TRACK} = 3.3\mu F$  (ceramic) (ESR  $\leq 1.5\Omega$ ),  $C_{OUT\_TRK} = 10\mu F$  (ESR  $\leq 1.5\Omega$ ),  $C_{REF} = 1000pF$ ,  $V_{OUT\_LDO} = 5V$ ,  $T_A = T_J = -40^\circ C$  to  $+125^\circ C$ , unless otherwise noted. Typical values are at  $T_A = +25^\circ C$ .) (Note 1)

PARAMETER	SYMBOL	CONDITIONS	MIN	TYP	MAX	UNITS
IN Undervoltage Lockout	$V_{UVLO}$	$V_{IN}$ falling, GATE disabled	4.10	4.27	4.45	V
IN Undervoltage Lockout Hysteresis	$V_{UVLO\_HYST}$			260		mV
Internal Voltage Reference	REF	$I_{REF} = 0\mu A$	1.21	1.235	1.26	V
Internal Voltage Reference Maximum Current	$I_{REF}$	$\Delta V_{REF} = \pm 200mV$	-6		+6	$\mu A$
Thermal-Shutdown Temperature	$T_{SHDN}$			+160		$^\circ C$
Thermal Hysteresis	$T_{HYST}$			20		$^\circ C$
<b>LDO</b>						
Output Voltage	$V_{OUT\_LDO}$	$I_{LOAD} = 1mA$ , $FB\_LDO = SGND$	4.92	5	5.09	V
		$I_{LOAD} = 300mA$ , $V_{IN} = 8V$ , $FB\_LDO = SGND$	4.80	5	5.11	
FB_LDO Set-Point Voltage	$V_{FB\_LDO}$	With respect to SGND, $I_{LOAD} = 1mA$ , $V_{OUT\_LDO} = 5V$ (adjustable output option)	1.21	1.235	1.26	V
Dual Mode™ FB_LDO Threshold	$V_{FB\_LDO\_TH}$	FB_LDO rising		0.125		V
		FB_LDO falling		0.064		
FB_LDO Input Current	$I_{FB\_LDO}$	$V_{FB\_LDO} = 1V$	-100		+100	nA
LDO Output Voltage Range	$V_{LDO\_ADJ}$	Adjustable output option (Note 2)	1.8		11.0	V
LDO Dropout Voltage (Note 3)	$V_{DO}$	$I_{LOAD} = 300mA$		775	1500	mV
		$I_{LOAD} = 200mA$		520	1000	
LDO Output Current	$I_{OUT\_LDO}$	(Note 4)	300			mA
LDO Output Current Limit	$I_{LIM\_LDO}$	$OUT\_LDO = GND$ , $V_{IN} = 6V$	330	500	700	mA
OUT_LDO Line Regulation	$\Delta V_{OUT}/\Delta V_{IN}$	$6V \leq V_{IN} \leq 40V$ , $I_{LOAD} = 1mA$ , $V_{OUT\_LDO} = 5V$		0.03	0.2	mV/V
		$6V \leq V_{IN} \leq 40V$ , $I_{LOAD} = 1mA$ , $V_{OUT\_LDO} = 3.3V$		0.03	0.1	
		$6V \leq V_{IN} \leq 40V$ , $I_{LOAD} = 20mA$ , $FB\_LDO = SGND$ , $V_{OUT\_LDO} = 5V$		0.27	1	
		$6V \leq V_{IN} \leq 40V$ , $I_{LOAD} = 20mA$ , $V_{OUT\_LDO} = 3.3V$		0.27	0.5	
OUT_LDO Load Regulation	$\Delta V_{OUT}/\Delta I_{OUT}$	1mA to 300mA, $V_{IN} = 8V$ , $FB\_LDO = SGND$ , $V_{OUT\_LDO} = 5V$		0.054	0.15	mV/mA
		1mA to 300mA, $V_{IN} = 6.3V$ , $V_{OUT\_LDO} = 3.3V$		0.038	0.1	
OUT_LDO Power-Supply Rejection Ratio	PSRR	$I_{LOAD} = 10mA$ , $f = 100Hz$ , 500mVp-p, $C_{OUT\_LDO} = 22\mu F$ , $V_{OUT\_LDO} = 5V$		60		dB

Dual Mode is a trademark of Maxim Integrated Products, Inc.

# Automotive 300mA LDO Voltage Regulators with Tracker Output and Overvoltage Protector

## ELECTRICAL CHARACTERISTICS (continued)

( $V_{IN} = V_{TRACK} = +14V$ ,  $V_{SGND} = V_{PGND} = 0V$ ,  $C_{GATE} = 6000pF$ ,  $C_{IN} = 10\mu F$  (ESR  $\leq 1.5\Omega$ ),  $C_{OUT\_LDO} = 22\mu F$  (ceramic),  $C_{TRACK} = 3.3\mu F$  (ceramic) (ESR  $\leq 1.5\Omega$ ),  $C_{OUT\_TRK} = 10\mu F$  (ESR  $\leq 1.5\Omega$ ),  $C_{REF} = 1000pF$ ,  $V_{OUT\_LDO} = 5V$ ,  $T_A = T_J = -40^\circ C$  to  $+125^\circ C$ , unless otherwise noted. Typical values are at  $T_A = +25^\circ C$ .) (Note 1)

PARAMETER	SYMBOL	CONDITIONS	MIN	TYP	MAX	UNITS
OUT_LDO Startup Delay Time	$t_{STARTUP\_DELAY}$	$I_{OUT\_LDO} = 0mA$ , from EN_LDO rising to 10% of $V_{OUT\_LDO}$ (nominal), $FB\_LDO = SGND$		30		$\mu s$
OUT_LDO Overvoltage Protection Threshold	$V_{OV\_TH}$	1mA sink from OUT_LDO		105	110	% $V_{OUT\_LDO}$
OUT_LDO Overvoltage Protection Sink Current	$I_{OV}$	$V_{OUT\_LDO} = V_{OUT}$ (nominal) x 1.15	8	19		mA
<b>ENABLE/HOLD INPUTS</b>						
EN_LDO, EN_PROT, EN_TRK Input Threshold Voltage	$V_{IH}$		2			V
	$V_{IL}$				0.7	
EN_LDO, EN_PROT, EN_TRK Input Pulldown Current	$I_{EN\_PD}$	EN_ is internally pulled low to SGND		1		$\mu A$
HOLD Input Threshold Voltage	$V_{IH}$		1.4			V
	$V_{IL}$				0.4	
HOLD Input Pullup	$I_{HOLD\_PU}$	HOLD is internally pulled high to OUT_LDO		0.6		$\mu A$
<b>RESET</b>						
RESET Voltage Threshold High	$V_{RESET\_H}$	RESET goes HIGH when rising $V_{OUT\_LDO}$ crosses this threshold, $FB\_LDO = SGND$	90.0	92.5	95.0	% $V_{OUT\_LDO}$
		RESET goes HIGH when rising $V_{OUT\_LDO}$ crosses this threshold	90.0	92.5	95.0	% $V_{FB\_LDO}$
RESET Voltage Threshold Low	$V_{RESET\_L}$	RESET goes LOW when falling $V_{OUT\_LDO}$ crosses this threshold, $FB\_LDO = SGND$	88	90	92	% $V_{OUT\_LDO}$
		RESET goes LOW when falling $V_{OUT\_LDO}$ crosses this threshold	88	90	92	% $V_{FB\_LDO}$
$V_{OUT\_LDO}$ to RESET Delay	$t_{RESET\_FALL}$	$V_{OUT\_LDO}$ falling, 0.1V/ $\mu s$		19		$\mu s$
CT Ramp Current	$I_{CT}$	$V_{CT} = 0V$	1.50	2.0	2.35	$\mu A$
CT Ramp Threshold	$V_{CT\_TH}$	$V_{CT}$ rising	1.19	1.235	1.27	V
RESET Output-Voltage Low	$V_{OL}$	$I_{SINK} = 1mA$ , output asserted			0.1	V
RESET Open-Drain Leakage Current	$I_{LEAK\_RESET}$	Output not asserted			150	nA
<b>LOAD DUMP PROTECTOR (MAX15008 only)</b>						
FB_PROT Threshold Voltage	$V_{TH\_PROT}$	FB_PROT rising	1.20	1.235	1.27	V
FB_PROT Threshold Hysteresis	$V_{HYST}$			4		% $V_{TH\_PROT}$
FB_PROT Input Current	$I_{FB\_PROT}$	$V_{FB\_PROT} = 1.4V$	-100		+100	nA
Startup Response Time	$t_{START}$	EN_PROT rising, EN_LDO = IN, to $V_{GATE} = 0.5V$		20		$\mu s$

# Automotive 300mA LDO Voltage Regulators with Tracker Output and Overvoltage Protector

MAX15008/MAX15010

## ELECTRICAL CHARACTERISTICS (continued)

( $V_{IN} = V_{TRACK} = +14V$ ,  $V_{SGND} = V_{PGND} = 0V$ ,  $C_{GATE} = 6000pF$ ,  $C_{IN} = 10\mu F$  (ESR  $\leq 1.5\Omega$ ),  $C_{OUT\_LDO} = 22\mu F$  (ceramic),  $C_{TRACK} = 3.3\mu F$  (ceramic) (ESR  $\leq 1.5\Omega$ ),  $C_{OUT\_TRK} = 10\mu F$  (ESR  $\leq 1.5\Omega$ ),  $C_{REF} = 1000pF$ ,  $V_{OUT\_LDO} = 5V$ ,  $T_A = T_J = -40^\circ C$  to  $+125^\circ C$ , unless otherwise noted. Typical values are at  $T_A = +25^\circ C$ .) (Note 1)

PARAMETER	SYMBOL	CONDITIONS	MIN	TYP	MAX	UNITS
GATE Rise Time	t <sub>GATE</sub>	GATE rising to +8V, V <sub>SOURCE</sub> = 0V		1		ms
FB_PROT to GATE Turn-Off Propagation Delay	t <sub>OV</sub>	FB_PROT step from V <sub>TH_PROT</sub> - 250mV to V <sub>TH_PROT</sub> + 250mV			0.6	μs
GATE Output High Voltage	V <sub>GATE</sub>	V <sub>SOURCE</sub> = V <sub>IN</sub> = 5.5V, R <sub>GATE</sub> to IN = 1MΩ	IN + 3.2	IN + 3.5	IN + 3.8	V
		V <sub>SOURCE</sub> = V <sub>IN</sub> ; V <sub>IN</sub> ≥ 14V, R <sub>GATE</sub> to IN = 1MΩ	IN + 7.0	IN + 8.1	IN + 9.5	
GATE Output Pulldown Current	I <sub>GATEPD</sub>	V <sub>GATE</sub> = 5V, V <sub>EN_PROT</sub> = 0V		63	100	mA
GATE Charge-Pump Current	I <sub>GATE</sub>	GATE = SGND		45		μA
GATE-to-SOURCE Clamp Voltage	V <sub>CLMP</sub>		12	16	18	V
<b>TRACKER</b>						
Tracker Supply Voltage Range	V <sub>TRACK</sub>		5		40	V
ADJ, FB_TRK Input Voltage	V <sub>ADJ</sub> , V <sub>FB_TRK</sub>		1.1		TRACK - 0.5	V
Tracker Output Common-Mode Range	V <sub>CM</sub>		1.1		TRACK - 0.5	V
Tracking Accuracy Over Line	ΔV <sub>Q_LINE</sub>	I <sub>OUT_LDO</sub> = 20mA, V <sub>FB_TRK</sub> = V <sub>OUT_TRK</sub> = 5V, V <sub>TRACK</sub> = 6V to 28V, ΔV <sub>Q</sub> = V <sub>FB_TRK</sub> - V <sub>ADJ</sub>	-3		+3	mV
Tracking Accuracy Over Load	ΔV <sub>Q_LOAD</sub>	V <sub>TRACK</sub> = 6V, 0.1mA ≤ I <sub>OUT_TRK</sub> ≤ 50mA, V <sub>ADJ</sub> = V <sub>OUT_TRK</sub> = 5V, ΔV <sub>Q</sub> = V <sub>FB_TRK</sub> - V <sub>ADJ</sub>	-3		+3	mV
ADJ, FB_TRK Input Current	I <sub>FB_TRK</sub> , I <sub>ADJ</sub>	V <sub>FB_TRK</sub> = V <sub>ADJ</sub> = 5V		0.03	0.2	μA
Dropout Voltage	V <sub>DO</sub>	V <sub>OUT_TRK</sub> = 5V, I <sub>OUT_TRK</sub> = 50mA		0.28	0.5	V
Tracker Output Current	I <sub>OUT_TRK</sub>	V <sub>ADJ</sub> = V <sub>OUT_TRK</sub> = 5V	50			mA
Output Current Limit	I <sub>OUT_TRK_LIM</sub>	V <sub>OUT_TRK</sub> = 0V	85	100	115	mA
Current Consumption	I <sub>Q</sub>	I <sub>Q</sub> = I <sub>TRACK</sub> - I <sub>OUT_TRK</sub> , I <sub>OUT_TRK</sub> = 50mA, V <sub>ADJ</sub> = V <sub>FB_TRK</sub> = 5V, EN_LDO = EN_PROT = SGND, EN_TRK = IN		2.7	6	mA
OUT_TRK Power-Supply Rejection Ratio	PSRR	I <sub>OUT_LDO</sub> = 10mA, f = 100Hz, 500mV <sub>P-P</sub> , V <sub>OUT_TRK</sub> = V <sub>FB_TRK</sub> , V <sub>ADJ</sub> = 5V		60		dB
OUT_TRK Reverse Current	I <sub>OUT_TRK_REVERSE</sub>	V <sub>TRACK</sub> = 14V, V <sub>OUT_TRK</sub> = V <sub>FB_TRK</sub> = 40V, V <sub>ADJ</sub> = 5V		10		μA

**Note 1:** Limits to -40°C are guaranteed by design.

**Note 2:** 1.8V is the minimum limit for proper HOLD functionality.

**Note 3:** Dropout is defined as V<sub>IN</sub> - V<sub>OUT\_LDO</sub> when V<sub>OUT\_LDO</sub> is 98% of the value of V<sub>OUT\_LDO</sub> for V<sub>IN</sub> = V<sub>OUT\_LDO</sub> + 1.5V.

**Note 4:** Maximum output current may be limited by the power dissipation of the package.

# Automotive 300mA LDO Voltage Regulators with Tracker Output and Overvoltage Protector

## Typical Operating Characteristics

( $V_{IN} = V_{EN-} = +14V$ ,  $C_{IN} = 10\mu F$ ,  $C_{OUT\_LDO} = 22\mu F$ ,  $C_{TRACK} = C_{OUT\_TRK} = 10\mu F$ ,  $V_{OUT\_LDO} = 5V$ ,  $FB\_LDO = SGND$ ,  $T_A = +25^\circ C$ , unless otherwise specified.)

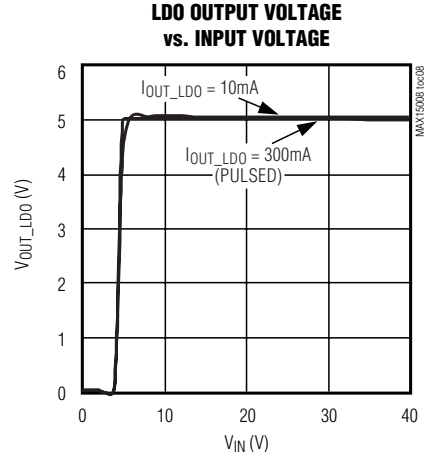
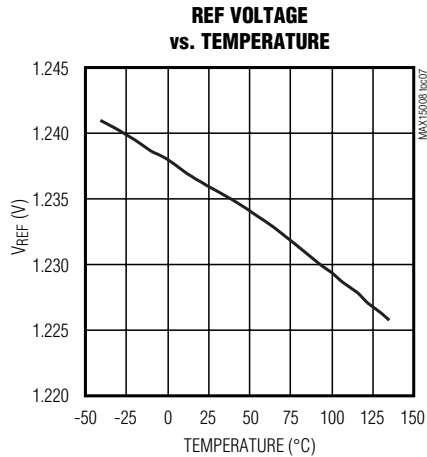
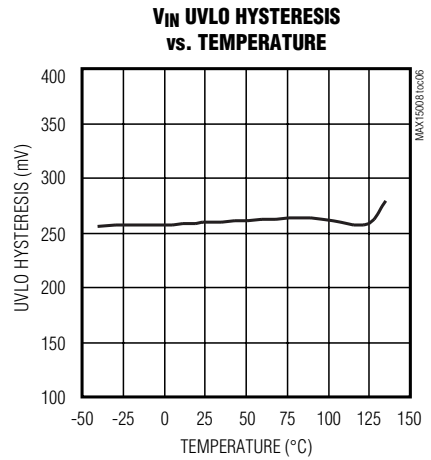
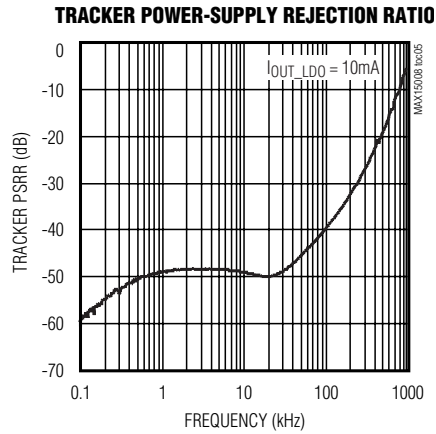
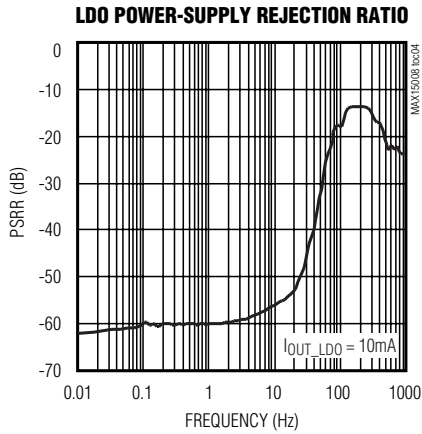
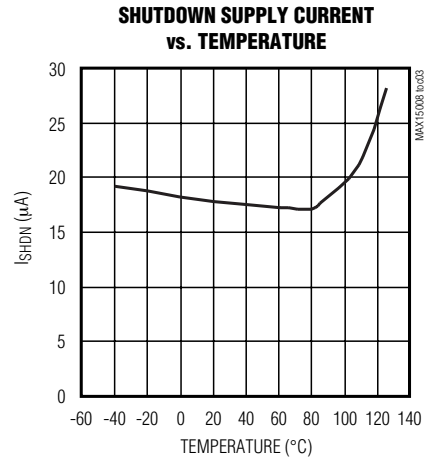
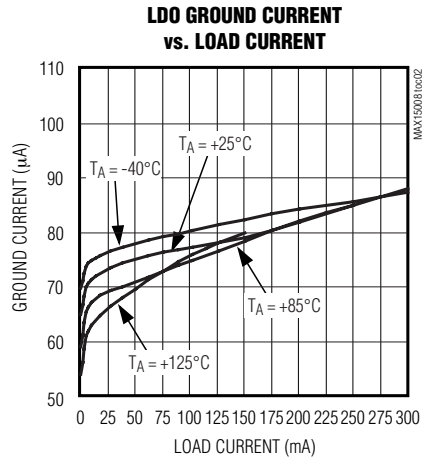
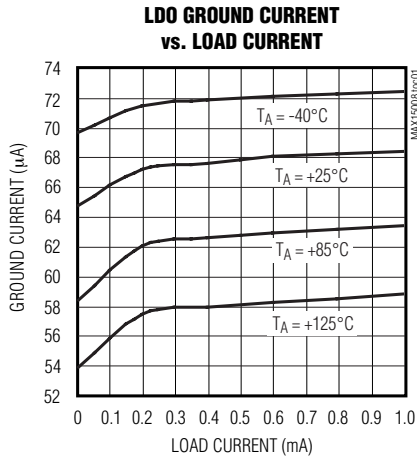

# Automotive 300mA LDO Voltage Regulators with Tracker Output and Overvoltage Protector

## Typical Operating Characteristics (continued)

( $V_{IN} = V_{EN-} = +14V$ ,  $C_{IN} = 10\mu F$ ,  $C_{OUT\_LDO} = 22\mu F$ ,  $C_{TRACK} = C_{OUT\_TRK} = 10\mu F$ ,  $V_{OUT\_LDO} = 5V$ ,  $FB\_LDO = SGND$ ,  $T_A = +25^\circ C$ , unless otherwise specified.)

MAX15008/MAX15010

**LDO LOAD-TRANSIENT RESPONSE**

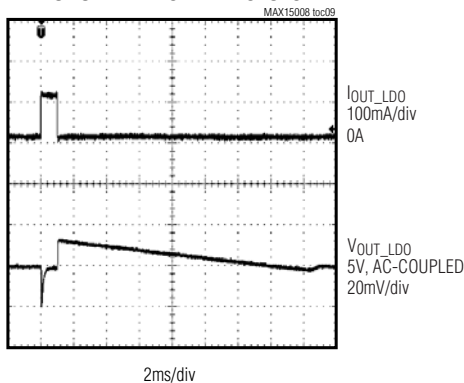

**LDO LOAD-TRANSIENT RESPONSE**

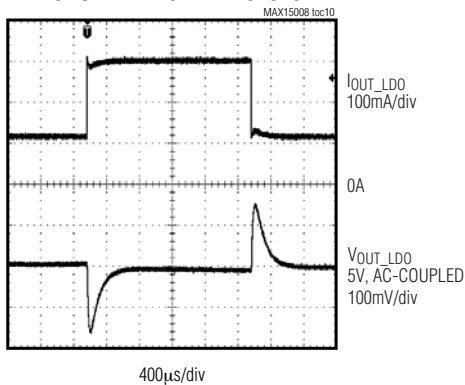

**LDO OUTPUT VOLTAGE vs. TEMPERATURE**

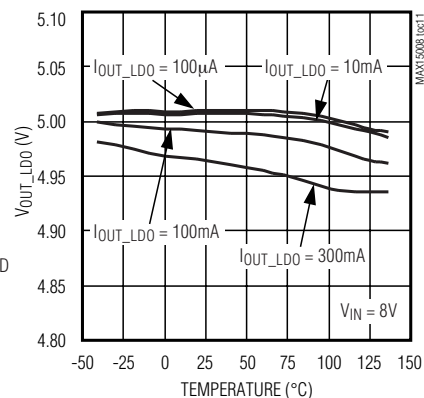

**TRACKER LOAD-TRANSIENT RESPONSE**

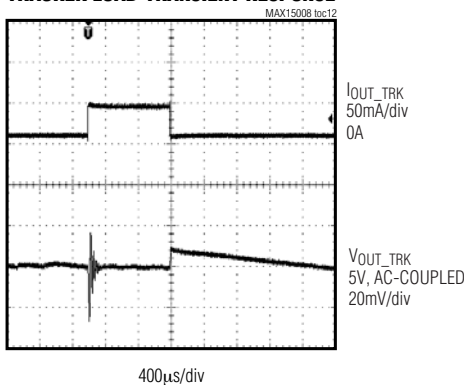

**TRACKER ACCURACY vs. LOAD CURRENT**

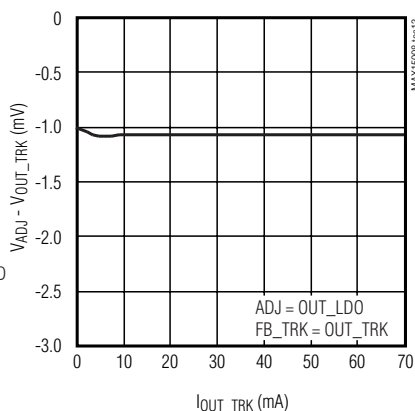

**TRACKER ACCURACY ( $V_{FB\_TRK} = V_{ADJ}$ ) vs. TEMPERATURE**

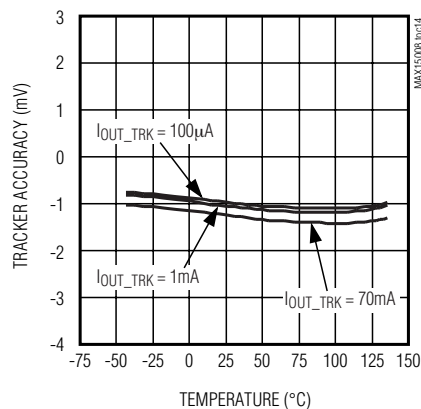

**LINE-TRANSIENT RESPONSE**

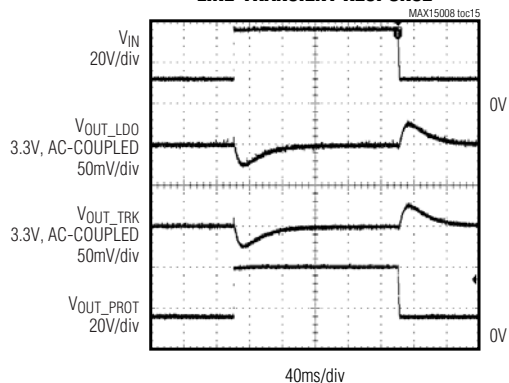

**LINE-TRANSIENT RESPONSE**

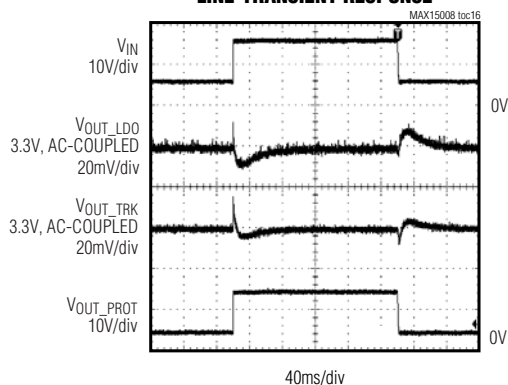

# Automotive 300mA LDO Voltage Regulators with Tracker Output and Overvoltage Protector

## Typical Operating Characteristics (continued)

( $V_{IN} = V_{EN\_} = +14V$ ,  $C_{IN} = 10\mu F$ ,  $C_{OUT\_LDO} = 22\mu F$ ,  $C_{TRACK} = C_{OUT\_TRK} = 10\mu F$ ,  $V_{OUT\_LDO} = 5V$ ,  $FB\_LDO = SGND$ ,  $T_A = +25^\circ C$ , unless otherwise specified.)

**LDO DROPOUT VOLTAGE vs. LOAD CURRENT**

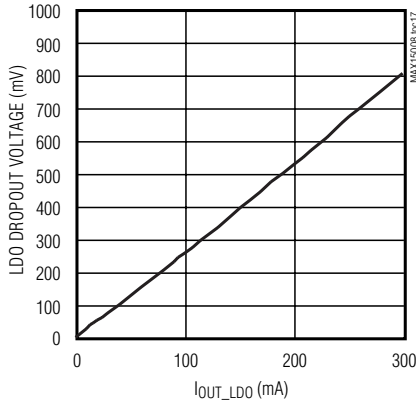

**STARTUP RESPONSE THROUGH  $V_{IN}$**

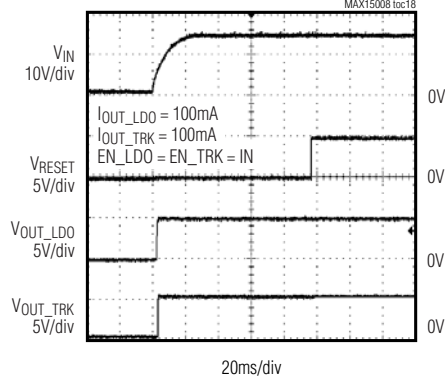

**STARTUP RESPONSE THROUGH EN**

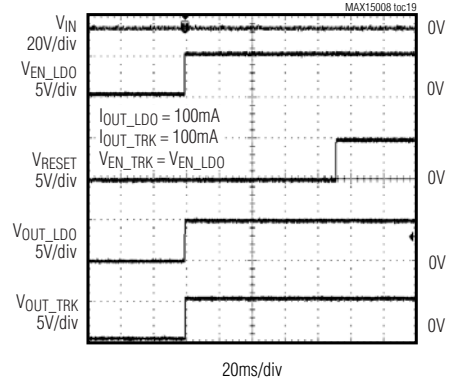

**SHUTDOWN RESPONSE THROUGH  $V_{IN}$**

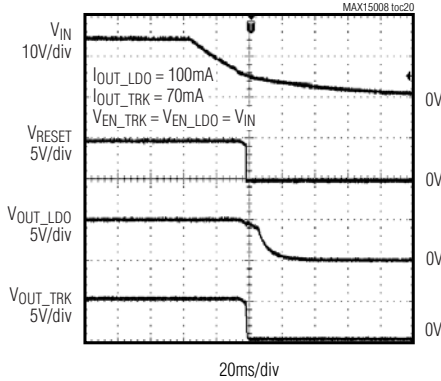

**SHUTDOWN RESPONSE THROUGH EN**

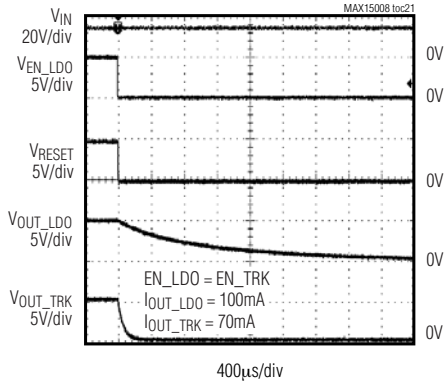

**LDO, EN\_LDO, AND HOLD TIMING**

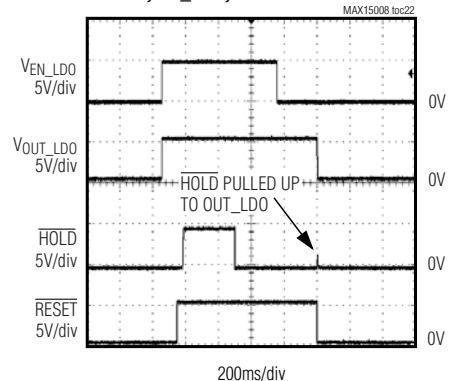

**GROUND CURRENT DISTRIBUTION HISTOGRAM ( $T_A = -40^\circ C$ )**

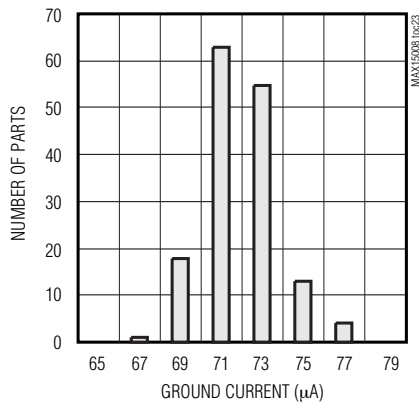

**GROUND CURRENT DISTRIBUTION HISTOGRAM ( $T_A = +125^\circ C$ )**

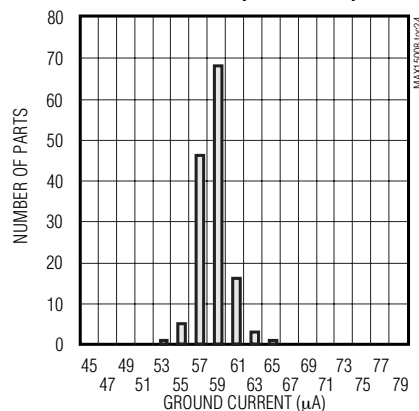



# Automotive 300mA LDO Voltage Regulators with Tracker Output and Overvoltage Protector

## Typical Operating Characteristics (continued)

( $V_{IN} = V_{EN-} = +14V$ ,  $C_{IN} = 10\mu F$ ,  $C_{OUT\_LDO} = 22\mu F$ ,  $C_{TRACK} = C_{OUT\_TRK} = 10\mu F$ ,  $V_{OUT\_LDO} = 5V$ ,  $FB\_LDO = SGND$ ,  $T_A = +25^\circ C$ , unless otherwise specified.)

MAX15008/MAX15010

**PROTECTOR GATE VOLTAGE vs. INPUT VOLTAGE (MAX15008 ONLY)**

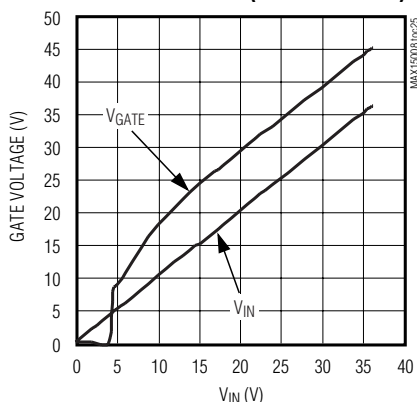

**PROTECTOR STARTUP RESPONSE (MAX15008 ONLY)**

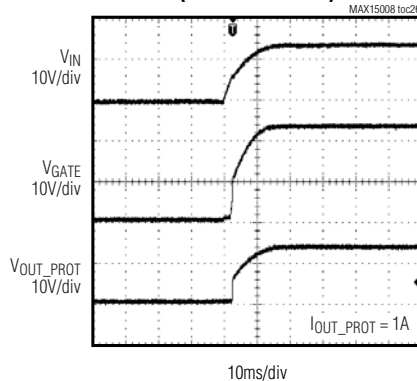

**OVERVOLTAGE SWITCH FAULT (MAX15008 ONLY)**

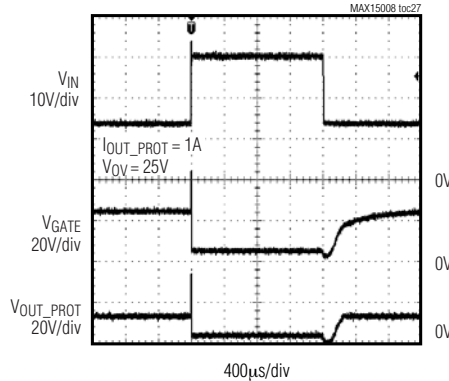

**OVERVOLTAGE LIMIT FAULT (MAX15008 ONLY)**

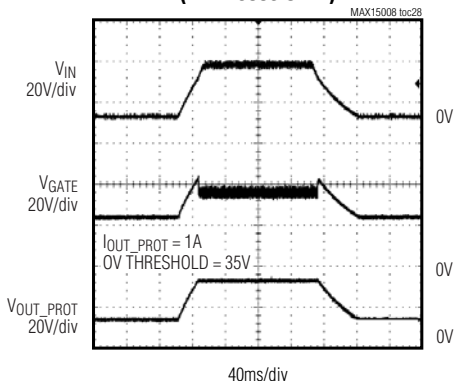

**RESET TIMEOUT DELAY vs. C\_RESET**

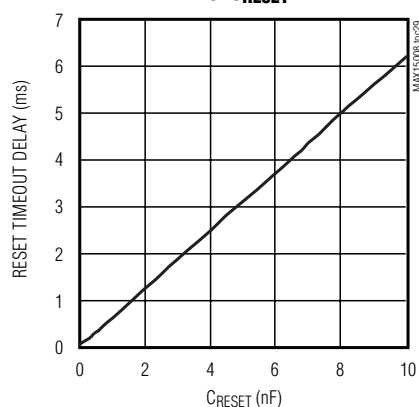

**RESET TIMEOUT DELAY vs. TEMPERATURE**

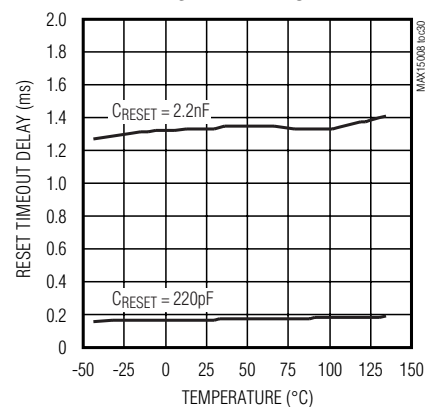

# Automotive 300mA LDO Voltage Regulators with Tracker Output and Overvoltage Protector

## Pin Description

PIN		NAME	FUNCTION
MAX15008	MAX15010		
1, 2, 8, 11, 23, 24, 26, 27, 28, 31, 32	1, 2, 8, 10–13, 18, 23, 24, 26, 27, 28, 31, 32	N.C.	No Connection. Not internally connected.
3	3	OUT_TRK	Tracker Output. Bypass OUT_TRK to SGND with a 10 $\mu$ F (min) capacitor with low ESR ( $\leq 1.5\Omega$ ).
4	4	ADJ	Tracker Amplifier Input. Connect ADJ to OUT_LDO or to an external source to track. Alternatively, connect ADJ to REF to provide the reference voltage to the tracker.
5	5	SGND	Signal Ground
6	6	PGND	Ground. PGND is also the return path for the overvoltage protector pulldown current for the MAX15008. In this case, connect PGND to SGND at the negative terminal of the bypass capacitor connected to the source of the external MOSFET. For the MAX15010, connect PGND to SGND together to the local ground plane.
7	7	$\overline{\text{RESET}}$	Active-Low Open-Drain Reset Output. $\overline{\text{RESET}}$ is low while OUT_LDO is below the reset threshold. Once OUT_LDO has exceeded the reset threshold, $\overline{\text{RESET}}$ remains low for the duration of the reset timeout period before going high.
9	9	CT	Reset Timeout Adjust Input. Connect a capacitor ( $C_{\text{RESET}}$ ) from CT to ground to adjust the reset timeout period. See the <i>Setting the <math>\overline{\text{RESET}}</math> Timeout Period</i> section.
10	—	FB_PROT	Overvoltage Threshold Adjustment Input. Connect FB_PROT to an external resistive voltage-divider network to adjust the desired overvoltage threshold. Use FB_PROT to monitor a system input or output voltage. See the <i>Setting the Overvoltage Threshold (MAX15008 Only)</i> section.
12	—	GATE	Protector Gate Drive Output. Connect GATE to the gate of an external n-channel MOSFET. GATE is the output of a charge pump with a 45 $\mu$ A pullup current to 7.1V (typ) above IN during normal operation. GATE is quickly turned off through a 63mA internal pulldown during an overvoltage condition. GATE then remains low until FB_PROT has decreased 96% below the threshold. GATE pulls low when EN_PROT is low.
13	—	SOURCE	Output-Voltage Sense Input. Connect SOURCE to the source of the external n-channel MOSFET.
14	14	REF	1.235V Voltage Reference Output. Bypass REF to SGND with a 1nF or larger capacitor.

# Automotive 300mA LDO Voltage Regulators with Tracker Output and Overvoltage Protector

## Pin Description (continued)

PIN		NAME	FUNCTION
MAX15008	MAX15010		
15	15	FB_LDO	LDO Voltage Feedback Input. Connect FB_LDO to SGND to select the preset +5V output voltage. Connect FB_LDO to an external resistive voltage-divider for adjustable output operation. See the <i>Setting the Output Voltage</i> section.
16	16	EN_LDO	Active-High LDO Enable Input. Connect EN_LDO to IN or to a logic-high voltage to turn on the regulator. To place the LDO in shutdown, pull EN_LDO low or leave unconnected and leave $\overline{\text{HOLD}}$ unconnected. EN_LDO is internally pulled to SGND through a 1 $\mu$ A current sink. See the <i>Control Logic</i> section.
17	17	EN_TRK	Active-High Tracker Enable Input. Connect EN_TRK to IN or to a logic-high voltage to turn on the tracker. Pull EN_TRK low or leave unconnected to place tracker in shutdown. EN_TRK is internally pulled to SGND through a 1 $\mu$ A current sink.
18	—	EN_PROT	Protector Enable Input. Drive EN_PROT low to force GATE low and turn off the external n-channel MOSFET. EN_PROT is internally pulled to SGND by a 1 $\mu$ A sink. Connect EN_PROT to IN for normal operation.
19, 20	19, 20	IN	Regulator Input. Bypass IN to SGND with a 10 $\mu$ F capacitor ( $\text{ESR} \leq 1.5\Omega$ ).
21, 22	21, 22	OUT_LDO	LDO Regulator Output. Bypass OUT_LDO to SGND with a low-ESR capacitor with a minimum value of 22 $\mu$ F. Fixed +5V or adjustable output (+1.8V to +11V). See the <i>Setting the Output Voltage</i> section.
25	25	$\overline{\text{HOLD}}$	Active-Low Hold Input. If EN_LDO is high when $\overline{\text{HOLD}}$ is forced low, the regulator latches the state of the EN_LDO input and allows the regulator to remain turned on when EN_LDO is subsequently pulled low. To shut down the regulator, release $\overline{\text{HOLD}}$ after EN_LDO is pulled low. If $\overline{\text{HOLD}}$ functionality is unused, connect $\overline{\text{HOLD}}$ to OUT_LDO or leave unconnected. $\overline{\text{HOLD}}$ is internally pulled up to OUT_LDO through a 0.6 $\mu$ A current source. See the <i>Control Logic</i> section.
29	29	FB_TRK	Tracker Amplifier Feedback. Connect FB_TRK directly to OUT_TRK or through an external resistive voltage-divider.
30	30	TRACK	Tracker Input. Bypass TRACK to the SGND with a 3.3 $\mu$ F ceramic capacitor.
EP	EP	EP	Exposed Pad. Connect EP to SGND plane. EP also functions as a heatsink to maximize thermal dissipation. Do not use as the main ground connection.

MAX15008/MAX15010

# Automotive 300mA LDO Voltage Regulators with Tracker Output and Overvoltage Protector

Functional Diagram

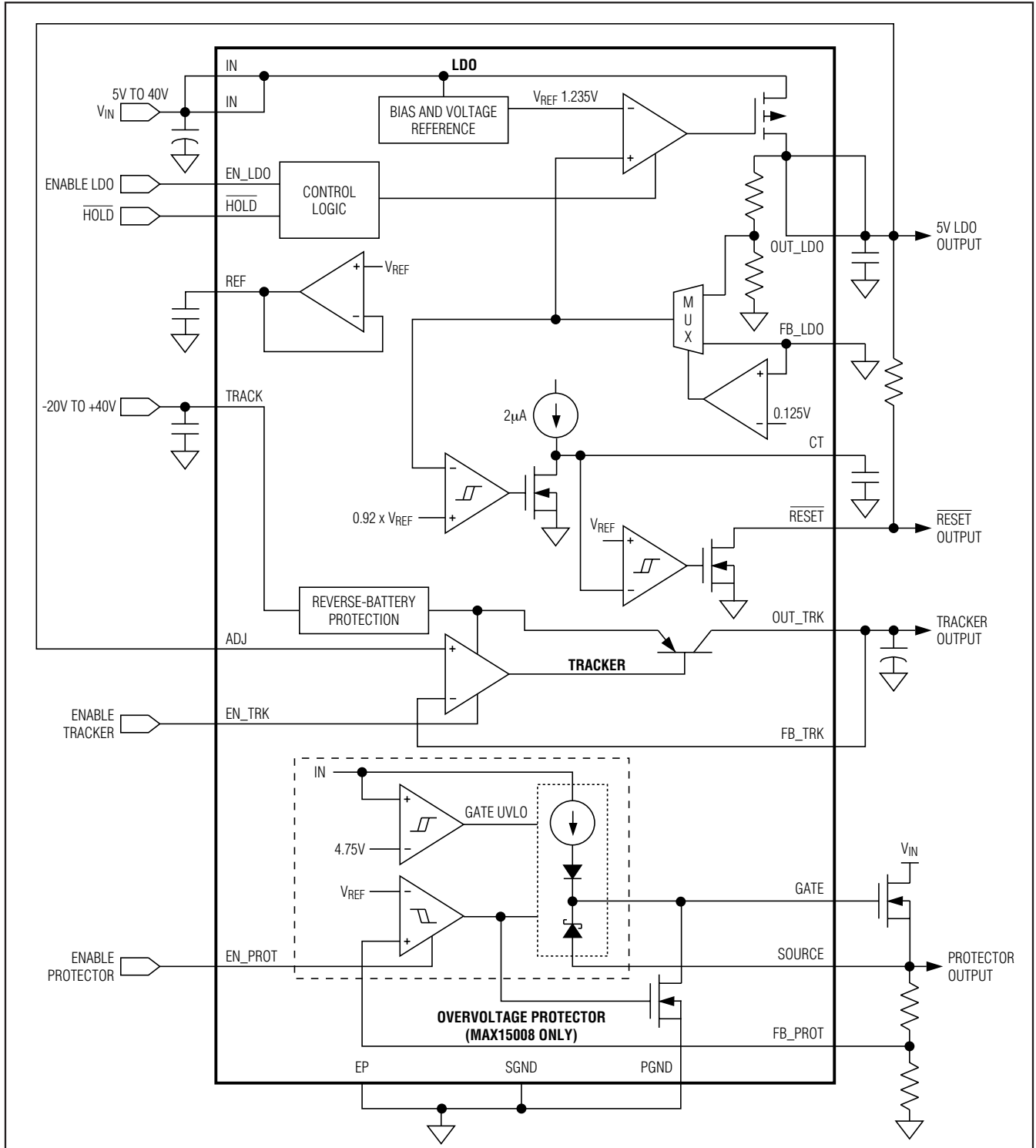

# Automotive 300mA LDO Voltage Regulators with Tracker Output and Overvoltage Protector

MAX15008/MAX15010

## Detailed Description

The MAX15008/MAX15010 integrate a 300mA LDO voltage regulator, a voltage tracker, and an OVP controller. These devices operate over a wide 5V to 40V supply voltage range and are able to withstand load-dump transients up to 45V.

The MAX15008/MAX15010 feature a 300mA LDO regulator that consumes less than 70 $\mu$ A of current under light-load conditions and feature a fixed 5V or an adjustable output voltage (1.8V to 11V). Connect FB\_LDO to ground to select a fixed 5V output voltage or select the LDO output voltage by connecting an external resistive voltage-divider at FB\_LDO. The regulator sources at least 300mA of current and includes a current limit of 330mA (min). Enable the LDO by pulling EN\_LDO high.

The tracker can be powered from the LDO input supply voltage or an independent voltage source. It is designed to supply power to a remote sensor and is able to handle the severe conditions in automotive applications. Set the tracker output voltage by connecting a resistive voltage-divider to OUT\_TRK and connecting ADJ to the tracking source. The tracker feedback, FB\_TRK, and a separate tracker reference voltage input, ADJ, offer the flexibility of setting the tracker output to be lower, equal to, or higher than the main (LDO) output. Pull EN\_TRK to SGND to turn the tracker off and keep the device in always-on, low-quiescent-current operation.

The OVP controller (MAX15008 only) relies on an external MOSFET with adequate voltage rating ( $V_{DS}$ ) to protect downstream circuitry from overvoltage transients. The OVP controller drives the gate of the external n-channel MOSFET, and is configurable to operate as an overvoltage protection switch or as a closed-loop voltage limiter.

## GATE Voltage (MAX15008 Only)

The MAX15008 uses a high-efficiency charge pump to generate the GATE voltage for the external n-channel MOSFET. Once the input voltage,  $V_{IN}$ , exceeds the undervoltage lockout (UVLO) threshold, the internal charge pump fully enhances the external n-channel MOSFET. An overvoltage condition occurs when the voltage at FB\_PROT goes above the threshold voltage,  $V_{TH\_PROT}$ . After  $V_{TH\_PROT}$  is exceeded, GATE is quickly pulled to PGND with a 63mA pulldown current. The MAX15008 includes an internal clamp from GATE to SOURCE that ensures that the voltage at GATE never exceeds one diode drop below SOURCE during gate

discharge. The voltage clamp also prevents the GATE-to-SOURCE voltage from exceeding the absolute maximum rating for the  $V_{GS}$  of the external MOSFET in case the source terminal is accidentally shorted to 0V.

## Overvoltage Monitoring (MAX15008 Only)

The OVP controller monitors the voltage at FB\_PROT and controls an external n-channel MOSFET, isolating, or limiting the load during an overvoltage condition. Operation in OVP switch mode or limiter mode depends on the connection between FB\_PROT and the external MOSFET.

## Overvoltage Switch Mode

When operating in OVP switch mode, the FB\_PROT divider is connected to the drain of the external MOSFET. The feedback path consists of the voltage-divider tapped at FB\_PROT, FB\_PROT's internal comparator, the internal gate charge pump/gate pulldown, and the external n-channel MOSFET (Figure 1). When the programmed overvoltage threshold is exceeded, the internal comparator quickly pulls GATE to ground and turns off the external MOSFET, disconnecting the power source from the load. In this configuration, the voltage at the source of the MOSFET is not monitored. When the voltage at FB\_PROT decreases below the overvoltage threshold, the MAX15008 raises the voltage at GATE, reconnecting the load to the power source.

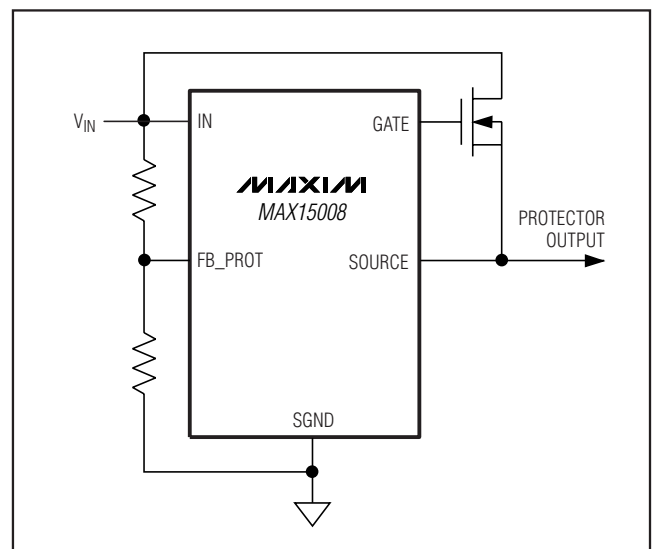

Figure 1. Overvoltage Switch Configuration (MAX15008)

# Automotive 300mA LDO Voltage Regulators with Tracker Output and Overvoltage Protector

## Overvoltage-Limiter Mode

When operating in overvoltage-limiter mode, the feedback path consists of SOURCE, FB\_PROT's internal comparator, the internal gate charge pump/gate pull-down, and the external n-channel MOSFET (Figure 2). This configuration results in the external MOSFET operating as a hysteretic voltage regulator.

During normal operation, GATE is enhanced 8.1V above  $V_{IN}$ . The external MOSFET source voltage is monitored through a resistive voltage-divider between SOURCE and FB\_PROT. When  $V_{SOURCE}$  exceeds the adjustable overvoltage threshold, an internal pulldown switch discharges the gate voltage and quickly turns the MOSFET off. Consequently, the source voltage begins to fall. The  $V_{SOURCE}$  fall time is dependent on the MOSFET's gate charge, the internal charge-pump current, the output load, and any load capacitance at SOURCE. When the voltage at FB\_PROT is below the overvoltage threshold by an amount equal to the hysteresis, the charge pump restarts and turns the MOSFET back on. In this way, the OVP controller attempts to regulate  $V_{SOURCE}$  around the overvoltage threshold. SOURCE remains high during overvoltage transients and the MOSFET continues to conduct during an overvoltage event. The hysteresis of the FB\_PROT comparator and the gate turn-on delay force the external MOSFET to operate in a switched on/off sequence during an overvoltage event.

Exercise caution when operating the MAX15008 in voltage-limiting mode for long durations. Care must be taken against prolonged or repeated exposure to overvoltage events while delivering large amounts of load current as the power dissipation in the external MOSFET may be high under these conditions. To prevent damage to the MOSFET, implement proper heatsinking. The capacitor connected between SOURCE and ground can also be damaged if the ripple current rating for the capacitor is exceeded.

As the transient voltage decreases, the voltage at SOURCE falls. For fast-rising transients and very large MOSFETs, connect an additional capacitor from GATE to PGND. This capacitor acts as a voltage-divider work-

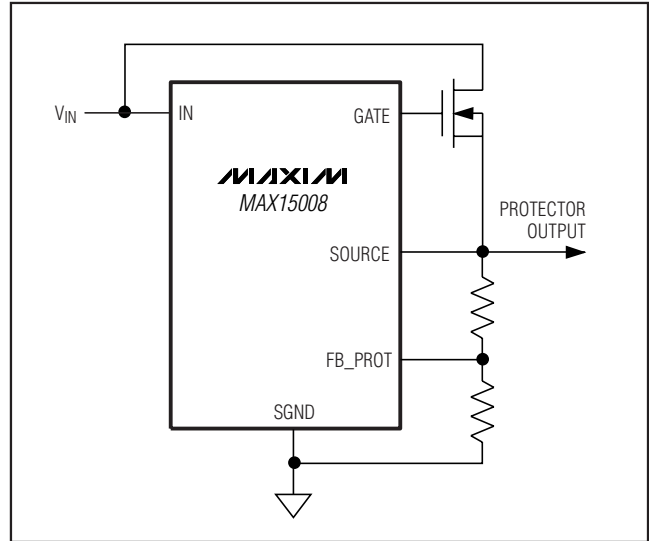

Figure 2. Overvoltage Limiter (MAX15008)

ing against the MOSFET's drain-to-gate capacitance. If using a very low gate charge MOSFET, additional capacitance from GATE to ground might be required to reduce the switching frequency.

## Control Logic

The MAX15008/MAX15010 LDO features two logic inputs, EN\_LDO and  $\overline{\text{HOLD}}$ , making these devices suitable for automotive applications. For example, when the ignition key signal drives EN\_LDO high, the regulator turns on and remains on even if EN\_LDO goes low, as long as  $\overline{\text{HOLD}}$  is forced low and stays low after initial regulator power-up. In this state, releasing  $\overline{\text{HOLD}}$  turns the regulator output (OUT\_LDO) off. This feature makes it possible to implement a self-holding circuit without external components. Forcing EN\_LDO low and  $\overline{\text{HOLD}}$  high (or unconnected) places the regulator into shutdown mode reducing the supply current to less than 16 $\mu\text{A}$ . Table 1 shows the state of OUT\_LDO with respect to EN\_LDO and  $\overline{\text{HOLD}}$ . Leave  $\overline{\text{HOLD}}$  unconnected or connect directly to OUT\_LDO to allow the EN\_LDO input to act as a standard on/off logic input for the regulator.

# Automotive 300mA LDO Voltage Regulators with Tracker Output and Overvoltage Protector

**Table 1. EN\_LDO/ $\overline{\text{HOLD}}$  Truth Table/State Table**

OPERATION STATE	EN_LDO	$\overline{\text{HOLD}}$	OUT_LDO	COMMENT
Initial State	Low	Don't care	OFF	EN_LDO is pulled to SGND through an internal pulldown. $\overline{\text{HOLD}}$ is unconnected and is internally pulled up to OUT_LDO. The regulator is disabled.
Turn-On State	High	Don't care	ON	EN_LDO is externally driven high turning regulator on. $\overline{\text{HOLD}}$ is pulled up to OUT_LDO.
Hold Setup State	High	Low	ON	$\overline{\text{HOLD}}$ is externally pulled low while EN_LDO remains high (latches EN_LDO state).
Hold State	Low	Low	ON	EN_LDO is driven low or left unconnected. $\overline{\text{HOLD}}$ remains externally pulled low keeping the regulator on.
Off State	Low	High or unconnected	OFF	$\overline{\text{HOLD}}$ is driven high or left unconnected while EN_LDO is low. The regulator is turned off and EN_LDO/ $\overline{\text{HOLD}}$ logic returns to the initial state.

## Applications Information

### Load Dump

Most automotive applications run off a multicell 12V lead-acid battery with a nominal voltage that swings between 9V and 16V, depending on load current, charging status, temperature, and battery age, etc. The battery voltage is distributed throughout the automobile and is locally regulated down to voltages required by the different system modules. Load dump occurs when the alternator is charging the battery and the battery becomes disconnected. Power in the alternator (behaving now essentially as an inductor) flows into the distributed power system and elevates the voltage seen at each module. The voltage spikes have rise times typically greater than 5ms and decay within several hundred milliseconds but can extend out to 1s or more depending on the characteristics of the charging system. These transients are capable of destroying semiconductors on the first fault event.

The MAX15008/MAX15010 feature load-dump transient protection up to +45V.

### Setting the Output Voltage

The MAX15008/MAX15010 feature dual-mode operation: these devices operate in either a preset voltage mode or an adjustable mode. In preset voltage mode, internal feedback resistors set the linear regulator out-

put voltage (V<sub>OUT\_LDO</sub>) to 5V. To select the preset 5V output voltage, connect FB\_LDO to SGND.

To select an adjustable output voltage between 1.8V and 11V, use two external resistors connected as a voltage-divider to FB\_LDO (Figure 3). Set the output voltage using the following equation:

$$V_{\text{OUT\_LDO}} = V_{\text{FB\_LDO}} \times (R_1 + R_2) / R_2$$

where V<sub>FB\_LDO</sub> = 1.235V and R<sub>2</sub> ≤ 50kΩ.

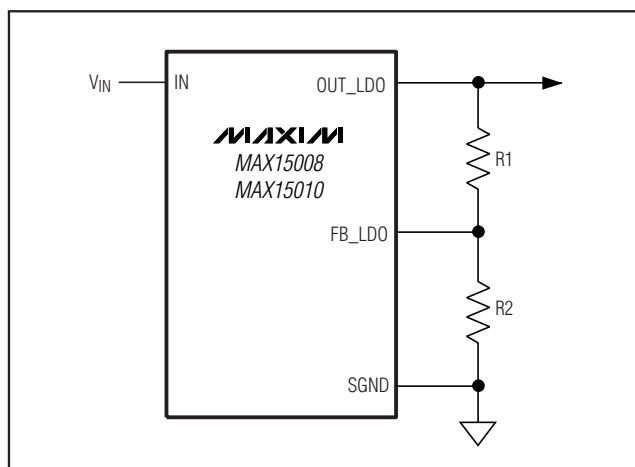

Figure 3. Setting the LDO Output Voltage

# Automotive 300mA LDO Voltage Regulators with Tracker Output and Overvoltage Protector

## Setting the RESET Timeout Period

The reset timeout period is adjustable to accommodate a variety of applications. Set the reset timeout period by connecting a capacitor,  $C_{RESET}$ , between CT and SGND. Use the following formula to select the reset timeout period,  $t_{RESET}$ :

$$t_{RESET} = C_{RESET} \times V_{CT\_TH} / I_{CT}$$

where  $t_{RESET}$  is in seconds and  $C_{RESET}$  is in  $\mu F$ .  $V_{CT\_TH}$  is the CT ramp threshold in volts and  $I_{CT}$  is the CT ramp current in  $\mu A$ , as described in the *Electrical Characteristics* table.

Leave CT open to select an internally fixed timeout period of  $10\mu s$ . To maintain reset timeout accuracy, use a low-leakage ( $< 10nA$ ) type capacitor.

## Tracker Input/Feedback Adjustment

The tracker can be powered from the LDO input supply voltage or an independent voltage source. It is designed to supply power to a remote sensor and its supply input, TRACK, is able to handle the severe conditions in automotive applications such as battery reversal and load-dump transients up to 45V.

The tracker feedback, FB\_TRK, and a separate tracker reference voltage input, ADJ, offer the flexibility of set-

ting the tracker output to be lower, equal to, or higher than the main (LDO) output. Other external voltages can also be tracked.

Connect ADJ to OUT\_LDO and FB\_TRK to OUT\_TRK to track the LDO output voltage directly (Figure 4a). To track a voltage higher than  $V_{OUT\_LDO}$ , directly connect ADJ to OUT\_LDO and connect FB\_TRK to OUT\_TRK through a resistive voltage-divider (Figure 4b). To track a voltage lower than the LDO regulator output,  $V_{OUT\_LDO}$ , directly connect FB\_TRK to OUT\_TRK and connect ADJ to OUT\_LDO through a resistive voltage-divider (Figure 4c). To track an external voltage  $V_X$  with a generic attenuation/amplification ratio, connect resistive voltage-dividers between ADJ and the voltage input or output to be tracked ( $V_X$ ), and between OUT\_TRK and FB\_TRK (Figure 4d). Pay attention to the resistive loading of the voltage  $V_X$  due to the divider  $R_5, R_6$ .

To track the internal REF voltage (1.235V), directly connect ADJ to REF. The voltage at FB\_TRK or ADJ should be greater than or equal to 1.1V and less than  $V_{TRACK} - 0.5V$ . Resistors should have a tolerance of 1% or better. Their values should be low enough to ensure that the divider current is at least 100x the maximum input bias current at pins FB\_TRK and ADJ ( $I_{FB\_TRK\_ADJ, max} = 0.2\mu A$ ).

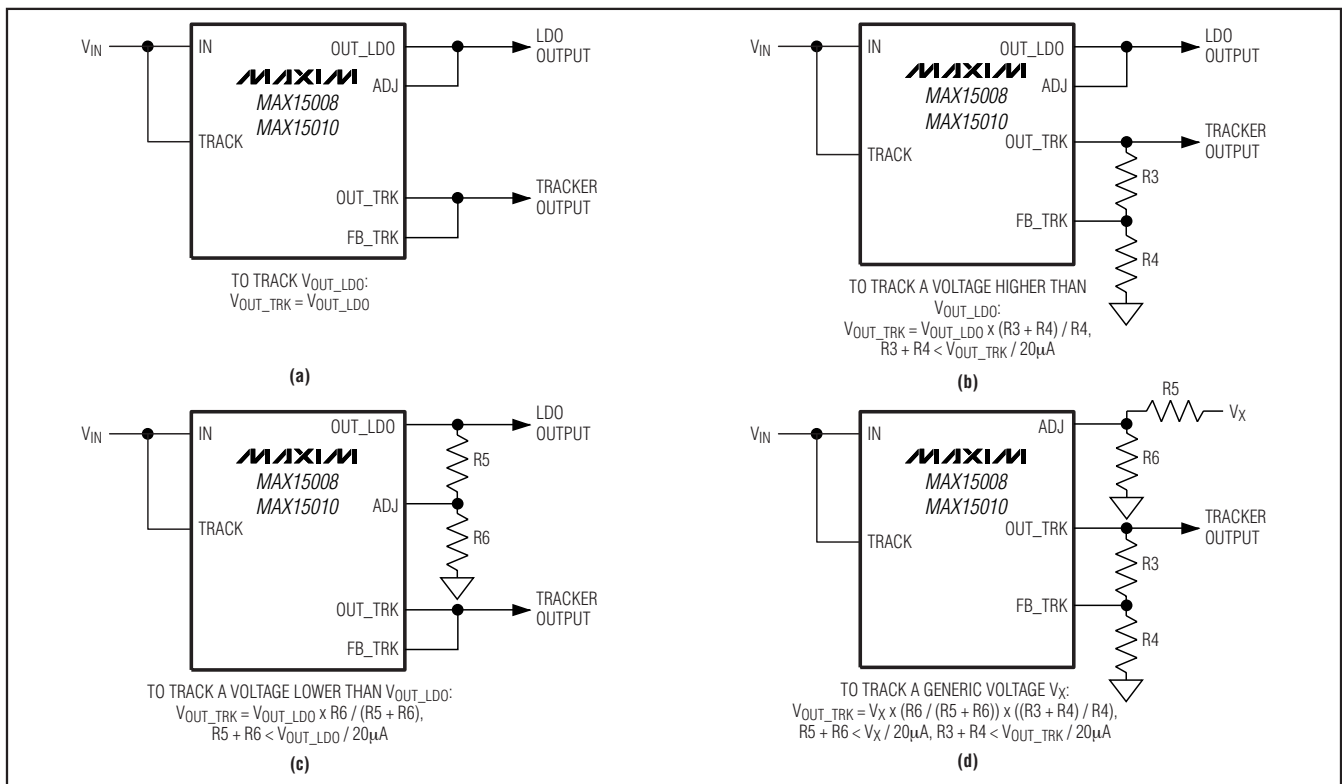

Figure 4. Tracker Input and Feedback Adjustment



# Automotive 300mA LDO Voltage Regulators with Tracker Output and Overvoltage Protector

MAX15008/MAX15010

## Setting the Overvoltage Threshold (MAX15008 Only)

The MAX15008 provides an accurate means to set the overvoltage threshold for the OVP controller using FB\_PROT. Use a resistive voltage-divider to set the desired overvoltage threshold (Figure 5). FB\_PROT has a rising 1.235V threshold with a 4% falling hysteresis.

Begin by selecting the total end-to-end resistance,  $R_{TOTAL} = R_5 + R_6$ . Choose  $R_{TOTAL}$  to yield a total current equivalent to a minimum of  $100 \times I_{FB\_PROT}$  (FB\_PROT's input maximum bias current) at the desired overvoltage threshold. See the *Electrical Characteristics* table.

For example:

With an overvoltage threshold ( $V_{OV}$ ) set to 20V,  $R_{TOTAL} < 20V / (100 \times I_{FB\_PROT})$ , where  $I_{FB\_PROT}$  is FB\_PROT's maximum 100nA bias current:

$$R_{TOTAL} < 2M\Omega$$

Use the following formula to calculate  $R_6$ :

$$R_6 = V_{TH\_PROT} \times R_{TOTAL} / V_{OV}$$

where  $V_{TH\_PROT}$  is the 1.235V FB\_PROT rising threshold and  $V_{OV}$  is the desired overvoltage threshold.  $R_6 = 124k\Omega$ :

$$R_{TOTAL} = R_5 + R_6$$

where  $R_5 = 1.88M\Omega$ . Use a standard 1.87M $\Omega$  resistor.

A lower value for total resistance dissipates more power, but provides better accuracy and robustness against external disturbances.

## Input Transients Clamping

When the external MOSFET is turned off during an overvoltage event, stray inductance in the power path may cause additional input-voltage spikes that exceed the  $V_{DSS}$  rating of the external MOSFET or the absolute maximum rating for the MAX15008 (IN, TRACK). Minimize stray inductance in the power path using wide traces and minimize the loop area included by the power traces and the return ground path.

For further protection, add a zener diode or transient voltage suppressor (TVS) rated below the absolute maximum rating limits (Figure 6).

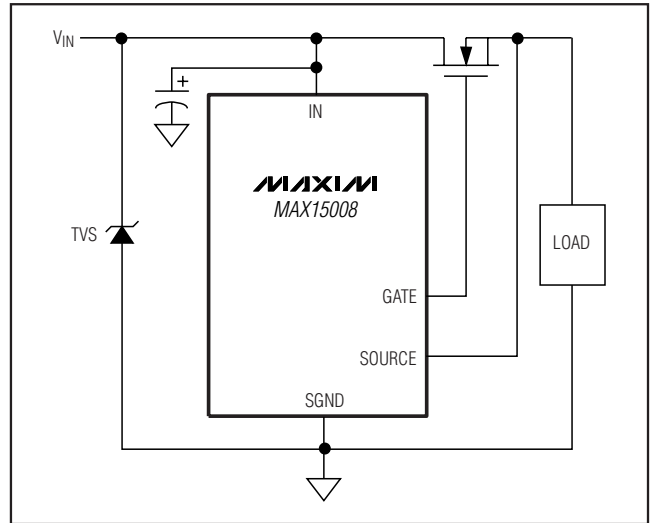

Figure 6. Protecting the MAX15008 Input from High-Voltage Transients

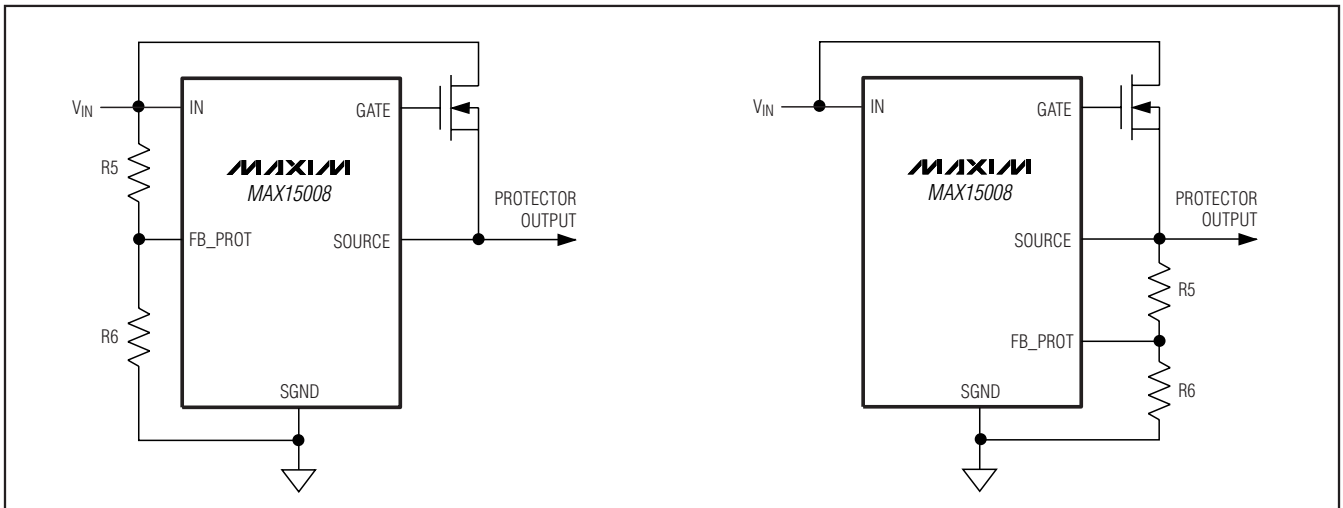

Figure 5. Setting the Overvoltage Threshold (MAX15008)

# Automotive 300mA LDO Voltage Regulators with Tracker Output and Overvoltage Protector

## External MOSFET Selection

Select the external MOSFET with adequate voltage rating,  $V_{DS}$ , to withstand the maximum expected load-dump input voltage. The on-resistance of the MOSFET,  $R_{DS(ON)}$ , should be low enough to maintain a minimal voltage drop at full load, limiting the power dissipation of the MOSFET.

During regular operation, the power dissipated by the MOSFET is:

$$P_{NORMAL} = I_{LOAD}^2 \times R_{DS(ON)}$$

Normally, this power loss is small and is safely handled by the MOSFET. However, when operating the MAX15008 in overvoltage-limiter mode under prolonged or frequent overvoltage events, select an external MOSFET with an appropriate power rating.

During an overvoltage event, the power dissipation in the external MOSFET is proportional to both load current and to the drain-source voltage, resulting in high power dissipated in the MOSFET (Figure 7). The power dissipated across the MOSFET is:

$$P_{OV\_LIMITER} = V_{Q1} \times I_{LOAD}$$

where  $V_{Q1}$  is the voltage across the MOSFET's drain and source during overvoltage-limiter operation, and  $I_{LOAD}$  is the load current.

## Overvoltage-Limiter Mode Switching Frequency

When the MAX15008 is configured in overvoltage-limiter mode, the external n-channel MOSFET is subse-

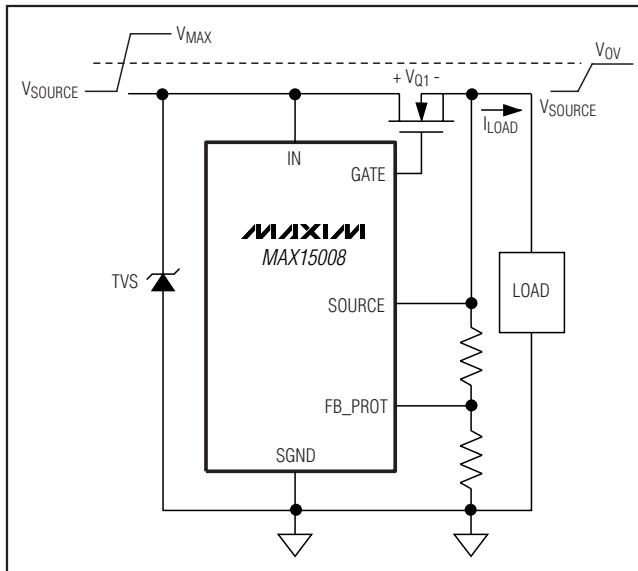

Figure 7. Power Dissipated Across MOSFETs During an Overvoltage Fault (Overvoltage Limiter Mode)

quently switched on and off during an overvoltage event. The output voltage at SOURCE resembles a periodic sawtooth waveform. Calculate the period of the waveform,  $t_{OVP}$ , by summing three time intervals (Figure 8):

$$t_{OVP} = t_1 + t_2 + t_3$$

where  $t_1$  is the  $V_{SOURCE}$  output discharge time,  $t_2$  is the GATE delay time, and  $t_3$  is the  $V_{SOURCE}$  output charge time.

During an overvoltage event, the power dissipated inside the MAX15008 is due to the gate pulldown current,  $I_{GATEPD}$ . This amount of power dissipation is worse when  $I_{SOURCE} = 0$  ( $C_{SOURCE}$  is discharged only by the internal current sink).

The worst-case internal power dissipation contribution in overvoltage-limiter mode,  $P_{OVP}$ , in watts can be approximated using the following equation:

$$P_{OVP} = V_{OV} \times 0.98 \times I_{GATEPD} \times \frac{t_1}{t_{OVP}}$$

where  $V_{OV}$  is the overvoltage threshold voltage in volts and  $I_{GATEPD}$  is the 63mA (typ) GATE pulldown current.

## Output Discharge Time ( $t_1$ )

When the voltage at SOURCE exceeds the adjusted overvoltage threshold, GATE's internal pulldown is enabled until  $V_{SOURCE}$  drops by 4%. The internal current sink,  $I_{GATEPD}$ , and the external load current,  $I_{LOAD}$ , discharge the external capacitance from SOURCE to ground.

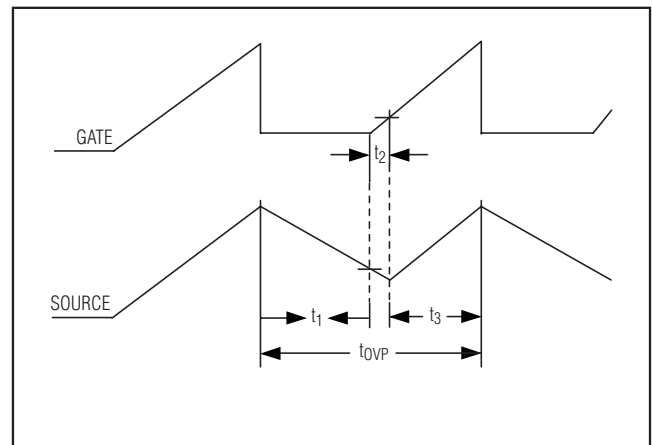

Figure 8. MAX15008 Timing Diagram

# Automotive 300mA LDO Voltage Regulators with Tracker Output and Overvoltage Protector

Calculate the discharge time,  $t_1$ , using the following equation:

$$t_1 = C_{\text{SOURCE}} \times \frac{0.04 \times V_{\text{OV}}}{I_{\text{LOAD}} + I_{\text{GATEPD}}}$$

where  $t_1$  is in ms,  $V_{\text{OV}}$  is the adjusted overvoltage threshold in volts,  $I_{\text{LOAD}}$  is the external load current in mA, and  $I_{\text{GATEPD}}$  is the 63mA (typ) internal pulldown current of GATE.  $C_{\text{SOURCE}}$  is the value of the capacitor connected between the source of the MOSFET and PGND in  $\mu\text{F}$ .

## GATE Delay Time ( $t_2$ )

When SOURCE falls 4% below the overvoltage threshold voltage, the internal current sink is disabled and the internal charge pump begins recharging the external GATE voltage. Due to the external load, the SOURCE voltage continues to drop until the gate of the MOSFET is recharged. The time needed to recharge GATE and re-enhance the external MOSFET is approximately:

$$t_2 = C_{\text{ISS}} \times \frac{V_{\text{GS(TH)}} + V_{\text{F}}}{I_{\text{GATE}}}$$

where  $t_2$  is in  $\mu\text{s}$ ,  $C_{\text{ISS}}$  is the input capacitance of the MOSFET in pF, and  $V_{\text{GS(TH)}}$  is the gate-to-source threshold voltage of the MOSFET in volts.  $V_{\text{F}}$  is the 0.7V (typ) internal clamp diode forward voltage of the MOSFET in volts, and  $I_{\text{GATE}}$  is the charge-pump current 45 $\mu\text{A}$  (typ). Any external capacitance between GATE and PGND will add up to  $C_{\text{ISS}}$ .

During  $t_2$ , the SOURCE capacitance,  $C_{\text{SOURCE}}$ , loses charge through the output load. The voltage across  $C_{\text{SOURCE}}$  decreases by  $\Delta V_2$  until the MOSFET reaches its  $V_{\text{GS(TH)}}$  threshold. Approximate  $\Delta V_2$  using the following formula:

$$\Delta V_2 = \frac{I_{\text{LOAD}} \times t_2}{C_{\text{SOURCE}}}$$

## SOURCE Output Charge Time ( $t_3$ )

Once the GATE voltage exceeds the gate-to-source threshold,  $V_{\text{GS(TH)}}$ , of the external MOSFET, the MOSFET turns on and the charge through the internal charge pump with respect to the drain potential,  $Q_{\text{G}}$ , determines the slope of the output-voltage rise. The time required for the SOURCE voltage to rise again to the overvoltage threshold is:

$$t_3 = \frac{C_{\text{RSS}} \times \Delta V_{\text{SOURCE}}}{I_{\text{GATE}}}$$

where  $\Delta V_{\text{SOURCE}} = (V_{\text{OV}} \times 0.04) + \Delta V_2$  in volts, and  $C_{\text{RSS}}$  is the MOSFET's reverse transfer capacitance in pF. Any external capacitance between GATE and PGND adds up to  $C_{\text{RSS}}$ .

## Power Dissipation/Junction Temperature

During normal operation, the MAX15008/MAX15010 has two main sources of internal power dissipation: the LDO and the voltage tracker.

Calculate the power dissipation due to the LDO as:

$$P_{\text{LDO}} = (V_{\text{IN}} - V_{\text{OUT\_LDO}}) \times I_{\text{OUT\_LDO}}$$

where  $V_{\text{IN}}$  is the LDO input supply voltage in volts,  $V_{\text{OUT\_LDO}}$  is the output voltage of the LDO in volts, and  $I_{\text{OUT\_LDO}}$  is the LDO total load current in mA.

Calculate power dissipation due to the tracker as:

$$P_{\text{TRK}} = (V_{\text{TRACK}} - V_{\text{OUT\_TRK}}) \times I_{\text{OUT\_TRK}}$$

where  $V_{\text{TRACK}}$  is the tracker input supply voltage in volts,  $V_{\text{OUT\_TRK}}$  is the output voltage of the tracker in volts, and  $I_{\text{OUT\_TRK}}$  is the tracker load current in mA.

The total power dissipation  $P_{\text{DISS}}$  in mW as:

$$P_{\text{DISS}} = P_{\text{LDO}} + P_{\text{TRK}}$$

For prolonged exposure to overvoltage events, use the  $V_{\text{IN}}$  and  $V_{\text{TRACK}}$  voltages expected during overvoltage conditions. Under these circumstances the corresponding internal power dissipation contribution,  $P_{\text{OVP}}$ , calculated in the *Overvoltage-Limiter Mode Switching Frequency* section should also be included in the total power dissipation,  $P_{\text{DISS}}$ .

For a given ambient temperature,  $T_{\text{A}}$ , calculate the junction temperature,  $T_{\text{J}}$ , as follows:

$$T_{\text{J}} = T_{\text{A}} + P_{\text{DISS}} \times \theta_{\text{JA}}$$

where  $T_{\text{J}}$  and  $T_{\text{A}}$  are in  $^{\circ}\text{C}$  and  $\theta_{\text{JA}}$  is the junction-to-ambient thermal resistance in  $^{\circ}\text{C}/\text{W}$  as listed in the *Absolute Maximum Ratings* section.

The junction temperature should never exceed  $+150^{\circ}\text{C}$  during normal operation.

## Thermal Protection

When the junction temperature exceeds  $T_{\text{J}} = +160^{\circ}\text{C}$ , the MAX15008/MAX15010 shut down to allow the device to cool. When the junction temperature drops to  $+140^{\circ}\text{C}$ , the thermal sensor turns all enabled blocks on again, resulting in a cycled output during continuous thermal-overload conditions. Thermal protection protects the MAX15008/MAX15010 from excessive power dissipation. For continuous operation, do not exceed the absolute maximum junction temperature rating of  $+150^{\circ}\text{C}$ .

# Automotive 300mA LDO Voltage Regulators with Tracker Output and Overvoltage Protector

## Typical Operating Circuits

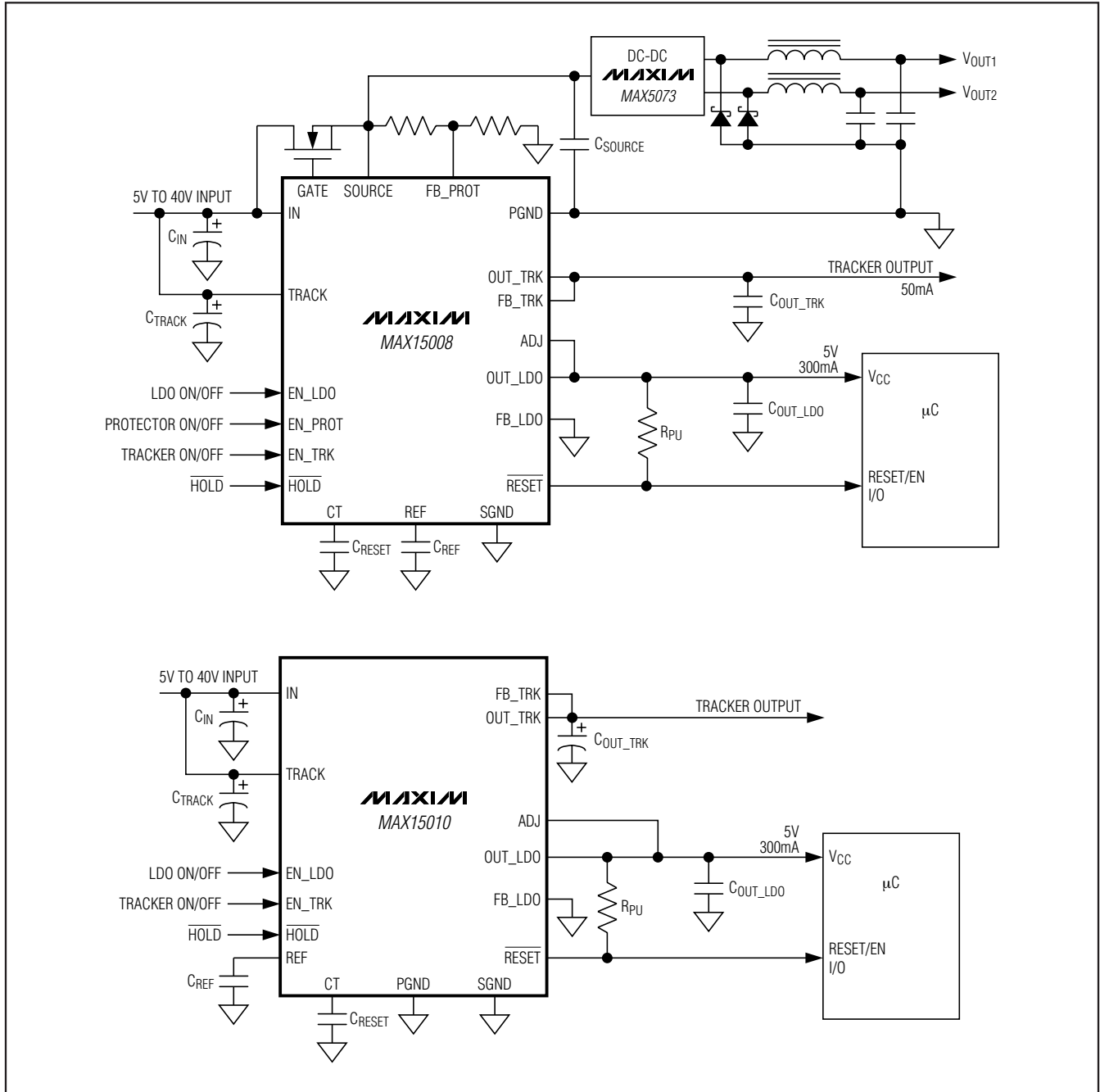

# Automotive 300mA LDO Voltage Regulators with Tracker Output and Overvoltage Protector

## Pin Configurations (continued)

## Chip Information

PROCESS: BiCMOS

**MAX15008/MAX15010**

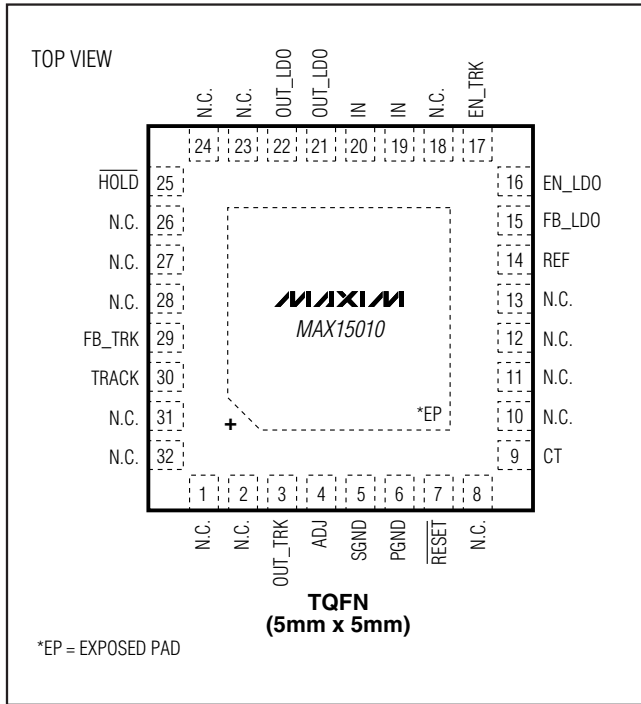



# Automotive 300mA LDO Voltage Regulators with Tracker Output and Overvoltage Protector

## Package Information (continued)

(The package drawing(s) in this data sheet may not reflect the most current specifications. For the latest package outline information go to [www.maxim-ic.com/packages](http://www.maxim-ic.com/packages).)

MAX15008/MAX15010

COMMON DIMENSIONS															
PKG.	16L 5x5			20L 5x5			28L 5x5			32L 5x5			40L 5x5		
SYMBOL	MIN.	NOM.	MAX.	MIN.	NOM.	MAX.	MIN.	NOM.	MAX.	MIN.	NOM.	MAX.	MIN.	NOM.	MAX.
A	0.70	0.75	0.80	0.70	0.75	0.80	0.70	0.75	0.80	0.70	0.75	0.80	0.70	0.75	0.80
A1	0	0.02	0.05	0	0.02	0.05	0	0.02	0.05	0	0.02	0.05	0	0.02	0.05
A2	0.20 REF.			0.20 REF.			0.20 REF.			0.20 REF.			0.20 REF.		
b	0.25	0.30	0.35	0.25	0.30	0.35	0.20	0.25	0.30	0.20	0.25	0.30	0.15	0.20	0.25
D	4.90	5.00	5.10	4.90	5.00	5.10	4.90	5.00	5.10	4.90	5.00	5.10	4.90	5.00	5.10
E	4.90	5.00	5.10	4.90	5.00	5.10	4.90	5.00	5.10	4.90	5.00	5.10	4.90	5.00	5.10
e	0.80 BSC.			0.65 BSC.			0.50 BSC.			0.50 BSC.			0.40 BSC.		
k	0.25	-	-	0.25	-	-	0.25	-	-	0.25	-	-	0.25	-	-
L	0.30	0.40	0.50	0.45	0.55	0.65	0.45	0.55	0.65	0.30	0.40	0.50	0.30	0.40	0.50
N	16			20			28			32			40		
ND	4			5			7			8			10		
NE	4			5			7			8			10		
JEDEC	VHBB			WHHC			WHHD-1			WHHD-2			----		

EXPOSED PAD VARIATIONS						
PKG. CODES	D2			E2		
	MIN.	NOM.	MAX.	MIN.	NOM.	MAX.
T1655-2	3.00	3.10	3.20	3.00	3.10	3.20
T1655-3	3.00	3.10	3.20	3.00	3.10	3.20
T1655N-1	3.00	3.10	3.20	3.00	3.10	3.20
T2055-3	3.00	3.10	3.20	3.00	3.10	3.20
T2055-4	3.00	3.10	3.20	3.00	3.10	3.20
T2055-5	3.15	3.25	3.35	3.15	3.25	3.35
T2055MN-5	3.15	3.25	3.35	3.15	3.25	3.35
T2855-3	3.15	3.25	3.35	3.15	3.25	3.35
T2855-4	2.60	2.70	2.80	2.60	2.70	2.80
T2855-5	2.60	2.70	2.80	2.60	2.70	2.80
T2855-6	3.15	3.25	3.35	3.15	3.25	3.35
T2855-7	2.60	2.70	2.80	2.60	2.70	2.80
T2855-8	3.15	3.25	3.35	3.15	3.25	3.35
T2855N-1	3.15	3.25	3.35	3.15	3.25	3.35
T3255-3	3.00	3.10	3.20	3.00	3.10	3.20
T3255-4	3.00	3.10	3.20	3.00	3.10	3.20
T3255M-4	3.00	3.10	3.20	3.00	3.10	3.20
T3255-5	3.00	3.10	3.20	3.00	3.10	3.20
T3255N-1	3.00	3.10	3.20	3.00	3.10	3.20
T4055-1	3.40	3.50	3.60	3.40	3.50	3.60
T4055-2	3.40	3.50	3.60	3.40	3.50	3.60
T4055MN-1	3.40	3.50	3.60	3.40	3.50	3.60

**NOTES:**

- DIMENSIONING & TOLERANCING CONFORM TO ASME Y14.5M-1994.
- ALL DIMENSIONS ARE IN MILLIMETERS. ANGLES ARE IN DEGREES.
- N IS THE TOTAL NUMBER OF TERMINALS.
- THE TERMINAL #1 IDENTIFIER AND TERMINAL NUMBERING CONVENTION SHALL CONFORM TO JEDEC 95-1 SPP-012. DETAILS OF TERMINAL #1 IDENTIFIER ARE OPTIONAL, BUT MUST BE LOCATED WITHIN THE ZONE INDICATED. THE TERMINAL #1 IDENTIFIER MAY BE EITHER A MOLD OR MARKED FEATURE.
- DIMENSION b APPLIES TO METALLIZED TERMINAL AND IS MEASURED BETWEEN 0.25 mm AND 0.30 mm FROM TERMINAL TIP.
- ND AND NE REFER TO THE NUMBER OF TERMINALS ON EACH D AND E SIDE RESPECTIVELY.
- DEPOPULATION IS POSSIBLE IN A SYMMETRICAL FASHION.
- COPLANARITY APPLIES TO THE EXPOSED HEAT SINK SLUG AS WELL AS THE TERMINALS.
- DRAWING CONFORMS TO JEDEC MO220, EXCEPT EXPOSED PAD DIMENSION FOR T2855-3, T2855-6, T4055-1 AND T4055-2.
- WARPAGE SHALL NOT EXCEED 0.10 mm.
- MARKING IS FOR PACKAGE ORIENTATION REFERENCE ONLY.
- NUMBER OF LEADS SHOWN ARE FOR REFERENCE ONLY.
- LEAD CENTERLINES TO BE AT TRUE POSITION AS DEFINED BY BASIC DIMENSION 'e', ±0.05.
- ALL DIMENSIONS APPLY TO BOTH LEADED AND P&FREE PARTS.

—DRAWING NOT TO SCALE—

TITLE: PACKAGE OUTLINE, 16,20,28,32,40L THIN QFN, 5x5x0.80mm		
APPROVAL	DOCUMENT CONTROL NO.	REV.
	21-0140	L 2/2

# Automotive 300mA LDO Voltage Regulators with Tracker Output and Overvoltage Protector

## Revision History

REVISION NUMBER	REVISION DATE	DESCRIPTION	PAGES CHANGED
0	9/07	Initial release	—
1	1/08	Removed future product asterisks, updated <i>Electrical Characteristics</i> table and <i>Typical Operating Characteristics</i> section.	1, 2, 6, 8

Maxim cannot assume responsibility for use of any circuitry other than circuitry entirely embodied in a Maxim product. No circuit patent licenses are implied. Maxim reserves the right to change the circuitry and specifications without notice at any time.

24 **Maxim Integrated Products, 120 San Gabriel Drive, Sunnyvale, CA 94086 408-737-7600**