

PART NUMBER	REV	FIRST USED
680819-1	A	854400-1
680819-2	A	565435-5

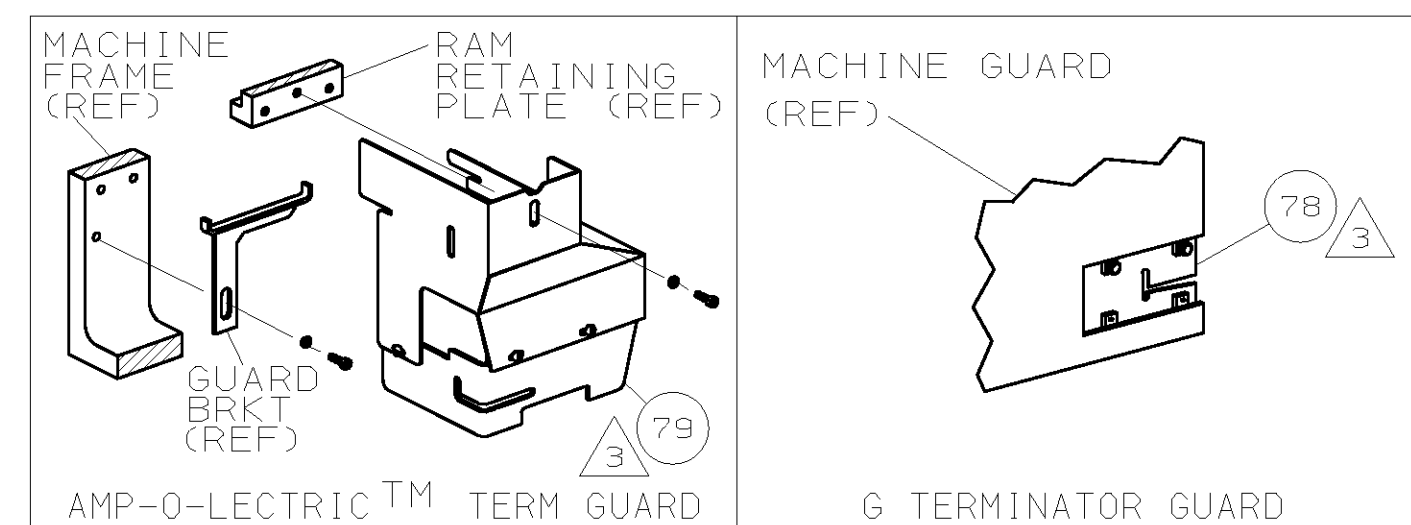

TERMINAL NAME:		CRIMPING DATA		
.110 SRS FLAG FASTON™ RECPT		PAD LTR	CRIMP HEIGHT	WIRE SIZE
141939		A	.047 ±.002 (1.2 ±0.05mm)	18
142893		B	.043 ±.002 (1.1 ±0.05mm)	20
		C	.040 ±.002 (1.02 ±0.05mm)	22
		D	NOT USED	
		CRIMP	SIZE	TYPE
		WIRE	.070	F
		INSUL	.110	0
		FEED	.430	APPL INST
		SET UP GAGE		LAYOUT
		458638-1		186
TERM APPL SPEC 114-35000		WIRE STRIP LENGTH .188-.219		

-1	LEADMAKER & BENCH MODEL G		AIRFEED	AIRFEED	
-2	BENCH MODEL K		AIRFEED		
1	-	-	C	692655-5	AIR FEED VALVE ASSY
REF	-	-	A	24042-2	VALVE, SHUT OFF
REF	-	-	C	692655-6	AIR FEED VALVE ASSY
1	1	-	B	460277-1	AIR FEED ASSY
2	2	-	A	3-21000-9	SCR, SHC 10-32x1.00 AIR ASSY
-	1	-	A	22294-6	ELBOW, TUBING 1/8NPT - 1/4 T
-	1	-	A	23238-1	QUICK DISCONNECT
12.00	12.00	IN	A	27319-4	TUBING, POLY-FLO Ø.25
					60
					59
					58
					57
					56
					55
					54
1	1	-	B	1-460680-8	FEED FINGER ASSY
					53
					52
					51
					50
					49
					48
					47
					46
1	1	-	A	690191-1	PLUG, NYLON
1	1	-	C	455674-5	RAM
1	1	-	A	690125-1	WASHER, LAMINATED
1	1	-	A	690124-4	WASHER, RAM
1	1	-	A	690686-2	BOLT, CRIMPER (5/16-24x1.00)
1	1	-	A	23241-6	BALL, STEEL
1	1	-	A	690170-1	SPRING, COMPRESSION
1	1	-	C	690142-1	DISC, INSULATION
1	1	-	D	354777-1	WIRE DISC, PLASTIC
1	1	-	A	22480-5	WASHER, SPRING
1	1	-	B	690212-1	POST, RAM
					35
					34
					33
					32
					31
					29
					28
1	1	-	B	3-690451-3	SPACER, STRIPPER
1	1	-	A	240639-2	STRIPPER
1	1	-	D	459717-1	PLATE, BASE
2	2	-	A	22354-8	DRAG, STUD
1	1	-	B	455678-1	PLATE, STRIP GUIDE
					25
					24
					23
2	2	-	A	4-22281-1	SPRING, DRAG
1	1	-	A	464451-1	ARM, STOCK DRAG
1	1	-	A	464452-5	DRAG, STOCK
1	1	-	B	454204-5	GUIDE, STRIP (REAR)
1	1	-	C	690871-1	GUIDE, STRIP (FRONT)
					19
					18
					17
					16
					15
					14
1	1	-	C	240645-9	SPACER, SHEAR PLATE (REAR)
1	1	-	B	690815-1	STOP, TERMINAL
1	1	-	B	690814-1	PLATE, REAR SHEAR
1	1	-	C	240645-3	SPACER, SHEAR PLATE (FRONT)
1	1	-	B	690619-6	PLATE, RETAINING
1	1	-	D	3-690618-3	ANVIL, WIRE
1	1	-	B	461297-2	BLADE, SLUG
1	1	-	D	690816-1	ANVIL, INSULATION
1	1	-	B	455888-1	SPACER, CRIMPER
1	1	-	B	238009-1	SPACER, BLOCK CRIMPER
1	1	-	C	461296-1	CRIMPER, INSULATION
1	1	-	B	1-455888-2	SPACER, CRIMPER
1	1	-	C	2-459736-4	CRIMPER, WIRE
					1

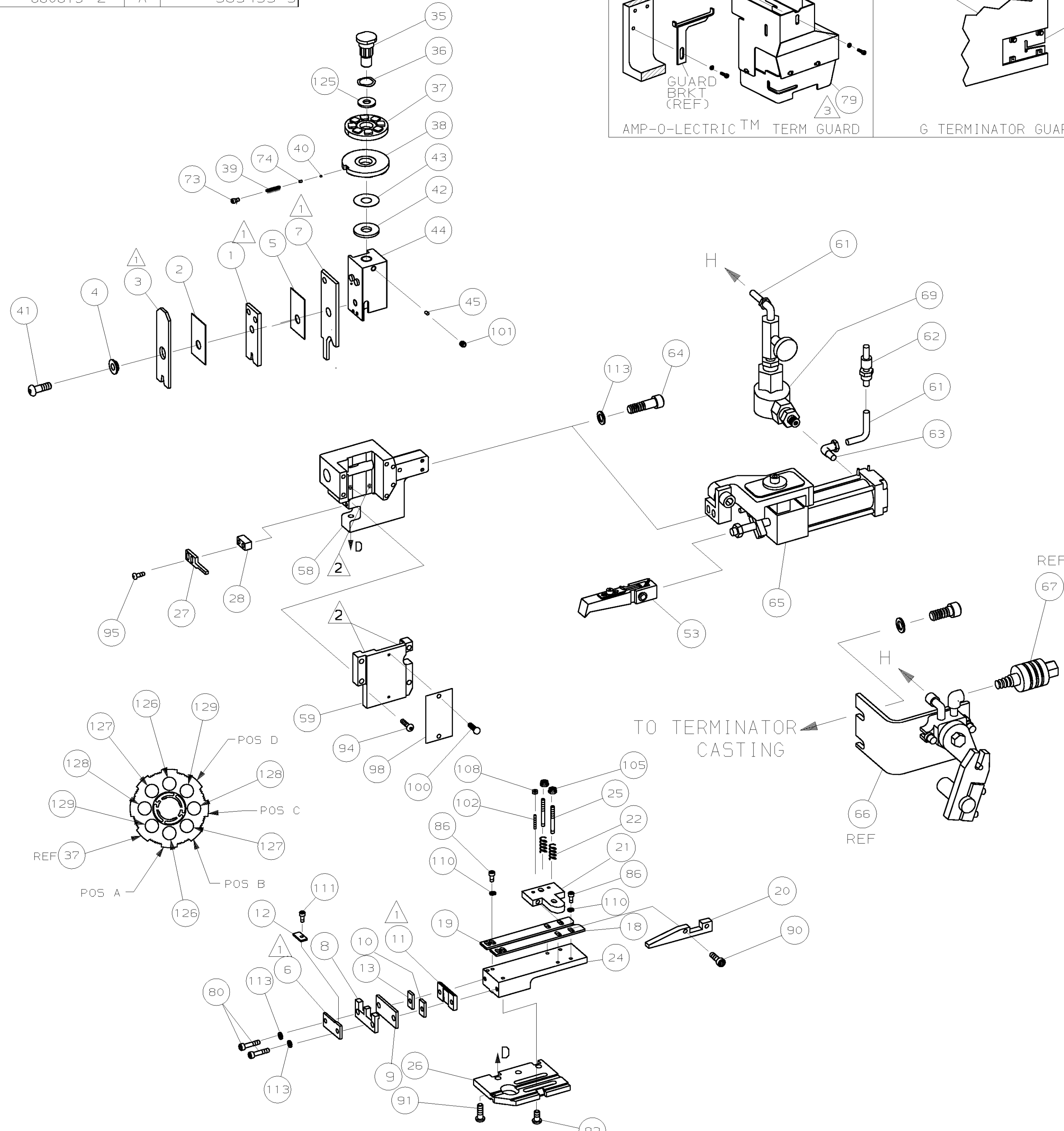

- ① RECOMMENDED SPARE PARTS.
- ② GREASE LIGHTLY.
- ③ GUARD MUST BE IN PLACE WHEN OPERATING APPLICATOR IN A BENCH MACHINE.
- ④ SEE DRAWING FOR COMPONENTS

2	2	-	C	4-354779-4	PIN, WIRE DISC (.3210)C	129
2	2	-	C	3-354779-8	PIN, WIRE DISC (.3180)B	128
2	2	-	C	2-354779-8	PIN, WIRE DISC (.3130)A	126
1	1	-	A	986950-1	WASHER, FLAT PRECISION	125
						124
						123
						122
						121
						120
						119
						118
						117
						116
						115
						114
2	2	-	A	21024-5	WASHER, LOCK (NO. 10) SHEAR PL	113
						112
1	1	-	A	1-21000-3	SCR, SHC (4-40x.25) STOP, TERM	111
4	4	-	A	21024-4	WASHER, LOCK (#8) SHEAR BL	110
						109
2	2	-	A	21018-4	NUT, HEX (4-40) DRAG	108
						107
						106
2	2	-	A	21022-2	NUT, HEX SL (8-32) DRAG STUD	105
						104
						103
2	2	-	A	4-21078-8	SKT SKT SET (4-40x.75) DRAG	102
1	1	-	A	21009-2	SCR, SKT SET (1/4-20x.25 )RAM	101
2	2	-	A	21017-2	SCR, DRIVE (#2x.19) ID PLATE	100
						99
1	1	-	B	461264-1	PLATE, IDENTIFICATION	98
						97
						96
2	2	-	A	2-21002-4	SCR, BHC (8-32x.75) STRIPPER	95
4	4	-	A	2-21002-9	SCR, BHC (10-32x.75) CAP	94
						93
4	4	-	A	3-21002-3	SCR, BHC (1/4-20x.50) ST GD PL	92
3	3	-	A	2-22733-8	SCR, BHC (1/4-20x.62) H5G	91
2	2	-	A	1-21000-3	SCR, SHC (4-40x.25) DRAG	90
						89
						88
						87
4	4	-	A	2-21000-6	SCR, SHC (8-32x.38) STRIP GUIDE	86
						85
						84
						83
						82
						81
2	2	-	A	3-21002-0	SCR, BUT CAP (10-32x. .875) SH PL	80
1	-	-	A	455750-8	GUARD ASSY	79
-	REF	-	A	679532-1	INSERT, GUARD	78
						77
						76
						75
1	1	-	A	690603-1	SPRING, ASSIST	74
1	1	-	A	23030-1	SCR, SKT CAP (6-32x.25) CP DSC	73
						72
						71

-2	-1	U/M	DWG SIZE	PART NO	DESCRIPTION	ITEM NO
REVISION OF EACH ASSY NO (WHEN BLANK, USE DWG REVISION)						
QTY REOD PER ASSY				PARTS LIST		

-2	-1	U/M	DWG SIZE	PART NO	DESCRIPTION	ITEM NO
REVISION OF EACH ASSY NO (WHEN BLANK, USE DWG REVISION)						
QTY REOD PER ASSY				PARTS LIST		

THIS DRAWING IS A CONTROLLED DOCUMENT.

THIS DRAWING IS UNRELEASED.  
RELEASED FOR PUBLICATION  
BY AMP INCORPORATED. ALL RIGHTS RESERVED.  
COPYRIGHT 19

LOC  
A  
DIST  
66

DIMENSIONS IN INCHES. DO NOT SCALE PRINT. TOLERANCES UNLESS OTHERWISE SPECIFIED:  
2 PLC DEC ±.25  
3 PLC DEC ±.  
4 PLC DEC ±.  
ANGLES ±.  
SURF TEXTURE: ✓  
REMOVE BURRS, BREAK SHARP EDGES R.015 MAX

MATL	HT TR	FIN
-	-	-

DR	4/16/99	APP	4/16/99
P.MATHIAS		T.ELBIN	
CHK	4/16/99	REL	4/16/99
C.ERISMAN			

**AMP** AMP Incorporated Harrisburg, PA 17105-3608

NAME: END FEED HDM APPLICATOR MACHINE REF: MINI APPL  
SCALE: - DWG NO: 680819 SHEET 1 OF 1 REV A

CASE CODE: 00779 CUSTOMER AND ASSEMBLY DRAWING 1 RESTRICTED TO