

NOTE 1. PER TRAY:100 PIECES.  
 2. REFER TO THE DF59 SERIES MATING/UNMATING OPERATION INSTRUCTION MANUAL(ETAD-H0496) FOR THE OPERATING OF THE PRODUCT.  
 3. UL(FILE NO. E52653),  
 C-UL(FILE NO. E52653) APPROVED PRODUCT.



3	PS	CLEAR
2	BRASS	CONTACT AREA : GOLD PLATING 0.2μm MIN UNDER PLATING : NICKEL PLATING 0.5μm MIN

1	PBT	UL94V-0 , NATURAL(WHITE)
NO.	MATERIAL	FINISH , REMARKS

UNITS	mm	SCALE	5 : 1	COUNT	1	DESCRIPTION OF REVISIONS	DESIGNED	CHECKED	DATE
						DIS-H-00000436	TS. KUMAZAWA	TS. FUKUSHIMA	15. 05. 15

APPROVED	: KI. AKIYAMA	10. 09. 28	DRAWING NO.	EDC3-332595-01
CHECKED	: OM. MIYAMOTO	10. 09. 27	PART NO.	DF59-3P-2SP(50)
DESIGNED	: KT. ISHII	10. 09. 27	CODE NO.	CL667-0018-3-50
DRAWN	: KT. ISHII	10. 09. 27		

# Operation Procedures for Crimp Socket

## 【 Mating 】

1. By positioning the convexity of the short circuit pin sides to the receptacle concavity, align the centers of the short circuit pin and the receptacle in pitch direction.

2. Press down at the center surface of short circuit pin.  
 Note>Press down until the short circuit pin touches to the receptacle.

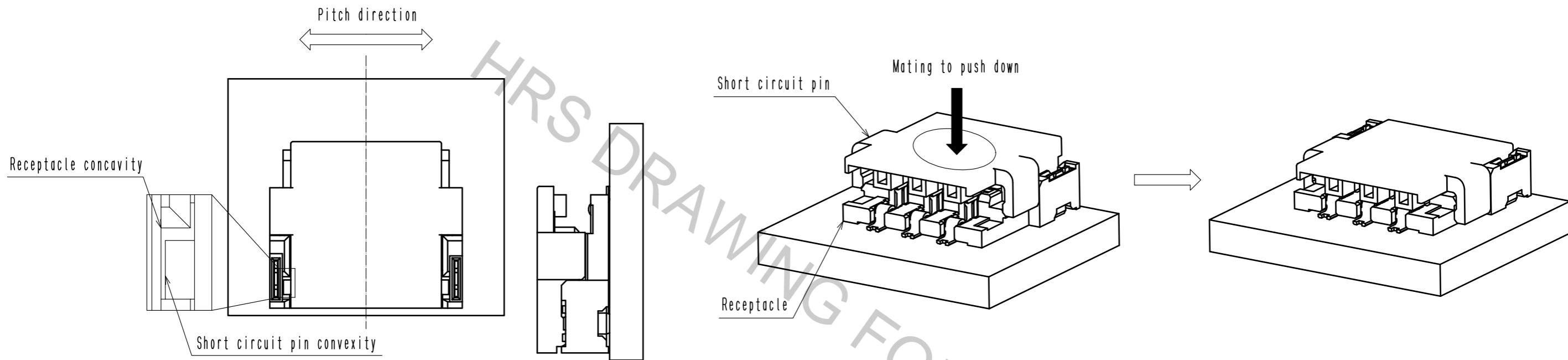

## 【 Unmating 】

1. Hook the lever with finger and lift up to the upper direction for unlock.

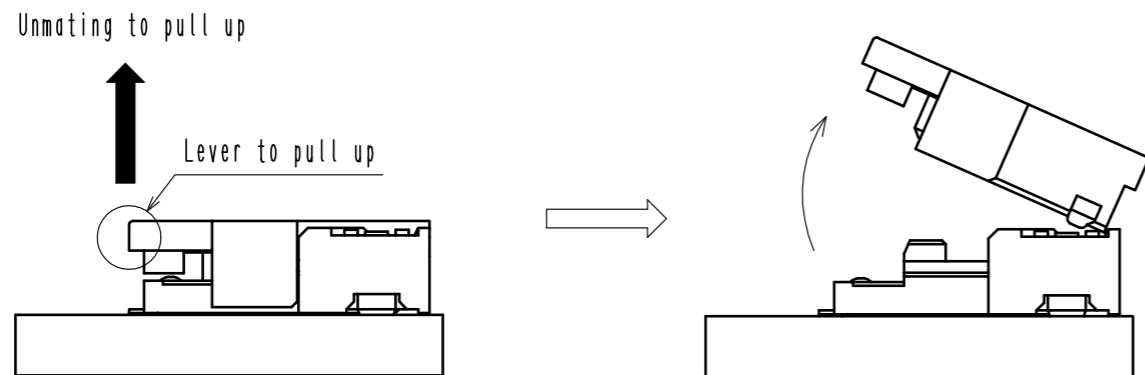

<b>HRS</b>	図番:	EDC3-332595-01	3/2
	製品名:	DF59-3P-2SP(50)	
	製品コード:	CL667-0018-3-50	