

UNCONTROLLED DOCUMENT

PART NUMBER  
SSL-LX20465LAD

REV.  
D

REV.	E.C.N. NUMBER AND REVISION COMMENTS	DATE
A	UPDATED AXIAL INTENSITY.	6.21.93
B	UPDATED SPECS.	2.16.93
C	CORRECTED DIM.	4.27.95
D	E.C.N. #10BRDR. & REDRAWN IN 3D.	9.27.00

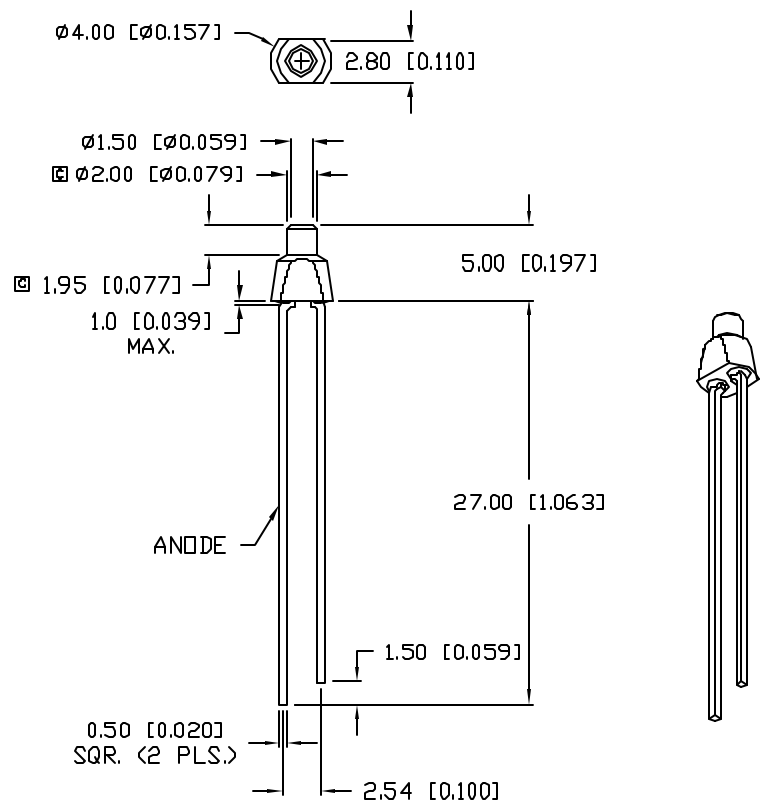

ELECTRO-OPTICAL CHARACTERISTICS  $T_A=25^{\circ}\text{C}$   $I_f=20\text{mA}$

PARAMETER	MIN	TYP	MAX	UNITS	TEST COND
PEAK WAVELENGTH		610		nm	
FORWARD VOLTAGE		2.0	2.5	V <sub>f</sub>	
REVERSE VOLTAGE	5.0			V <sub>r</sub>	I <sub>f</sub> =100μA
AXIAL INTENSITY		10		mcad	I <sub>f</sub> =20mA
		.8		mcad	I <sub>f</sub> =2mA
VIEWING ANGLE		70			2x theta
EMITTED COLOR:	AMBER				
EPOXY LENS FINISH:	AMBER TOP DIFFUSED				

LIMITS OF SAFE OPERATION AT 25°C

PARAMETER	MAX	UNITS
PEAK FORWARD CURRENT*	150	mA
STEADY CURRENT	30	mA
POWER DISSIPATION	105	mW
DERATE FROM 25°C	-1.6	mW/°C
OPERATING, STORAGE TEMP.	-40 TO +85	°C
SOLDERING TEMP.	+260	°C
2.0mm FROM BODY		3 SEC. MAX

\* t<10μS

\*UNLESS OTHERWISE SPECIFIED TOLERANCES PER DECIMAL PRECISION ARE: X=±1 (±0.039), XX=±0.5 (±0.020), XXX=±0.25 (±0.010), XXXX=±0.127 (±0.005). LEAD SIZE=±0.05 (±0.002), LEAD LENGTH=±0.75 (±0.030), MIN= <sup>+0.00</sup> <sub>-0.00</sub> DECIMAL PRECISION MAX= <sup>+0.00</sup> <sub>-0.00</sub> DECIMAL PRECISION

UNCONTROLLED DOCUMENT

REV. D	PART NUMBER SSL-LX20465LAD
-----------	-------------------------------

**CONFIDENTIAL INFORMATION**  
THE INFORMATION CONTAINED IN THIS DOCUMENT IS THE PROPERTY OF LUMEX INC. EXCEPT AS SPECIFICALLY AUTHORIZED IN WRITING BY LUMEX INC., THE HOLDER OF THIS DOCUMENT SHALL KEEP ALL INFORMATION CONTAINED HEREIN CONFIDENTIAL AND SHALL PROTECT SAME IN WHOLE OR IN PART FROM DISCLOSURE AND DISSEMINATION TO ALL THIRD PARTIES.



290 E. HELLEN ROAD  
PALATINE, ILLINOIS 60067  
PHONE: (847) 359-2790  
WEB: <http://www.lumex.com>

T-2mm TAPER BODY LED, TOP DIFFUSED,  
610nm AMBER LED, AMBER TOP DIFFUSED, LOW CURRENT.

**RELIABILITY NOTE**  
OUR MANY YEARS OF EXPERIENCE DATA ACCUMULATION INDICATE THAT SOLDER HEAT IS A MAJOR CAUSE OF EARLY AND FUTURE FAILURE. PLEASE PAY ATTENTION TO YOUR SOLDERING PROCESS.

DRAWN BY: BC	CHECKED BY:	APPROVED BY:	DATE: 11.30.92
			PAGE: 1 OF 1
			SCALE: N/A