

THIS DRAWING IS UNPUBLISHED. RELEASED FOR PUBLICATION, 19  
 © COPYRIGHT 19 BY AMP INCORPORATED. ALL INTERNATIONAL RIGHTS RESERVED.

|     |      |   |   |           |     |                                 |           |       |
|-----|------|---|---|-----------|-----|---------------------------------|-----------|-------|
| LOC | DIST | P | F | REVISIONS |     |                                 |           |       |
| AF  | 50   |   |   | ZONE      | LTR | DESCRIPTION                     | DATE      | APPD  |
|     |      |   |   |           | A   | RELEASE PER FASR & 0L10-0245-96 | 03/JAN/97 | PF/DS |

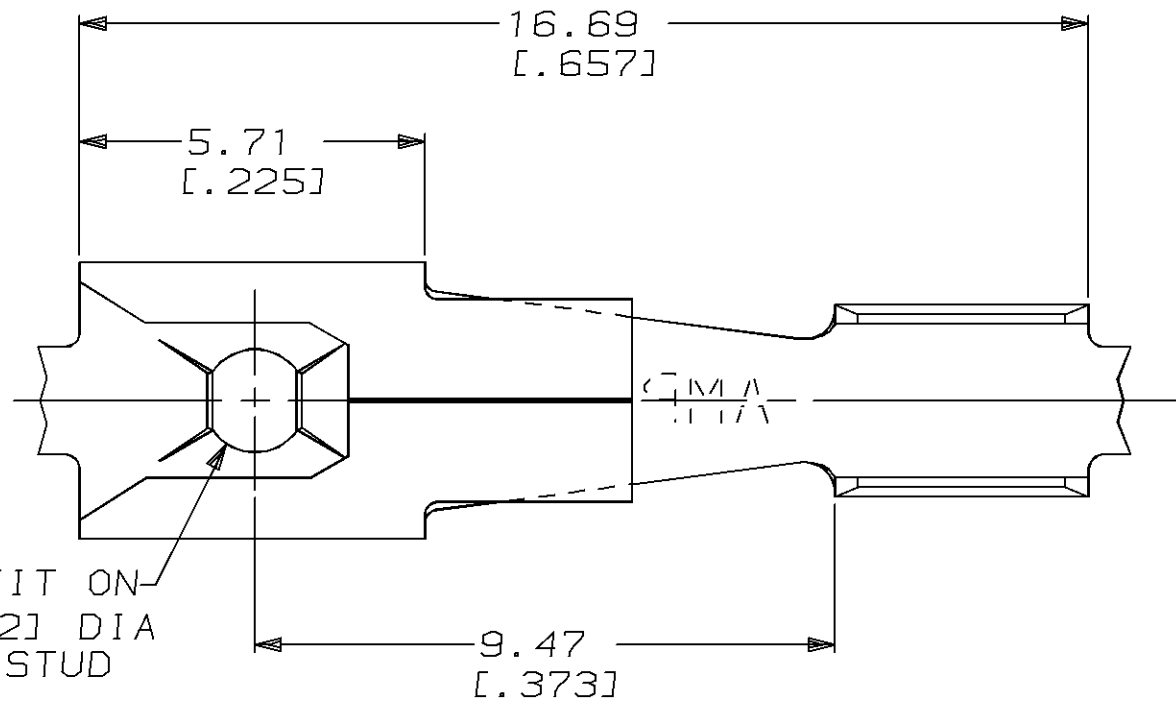

1 CONTINUOUS STRIP ON REEL.

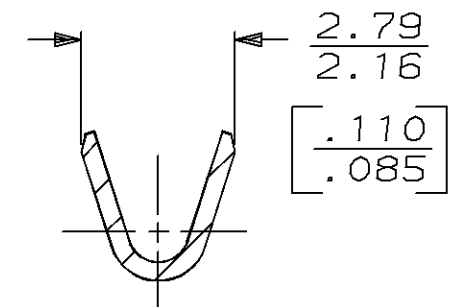
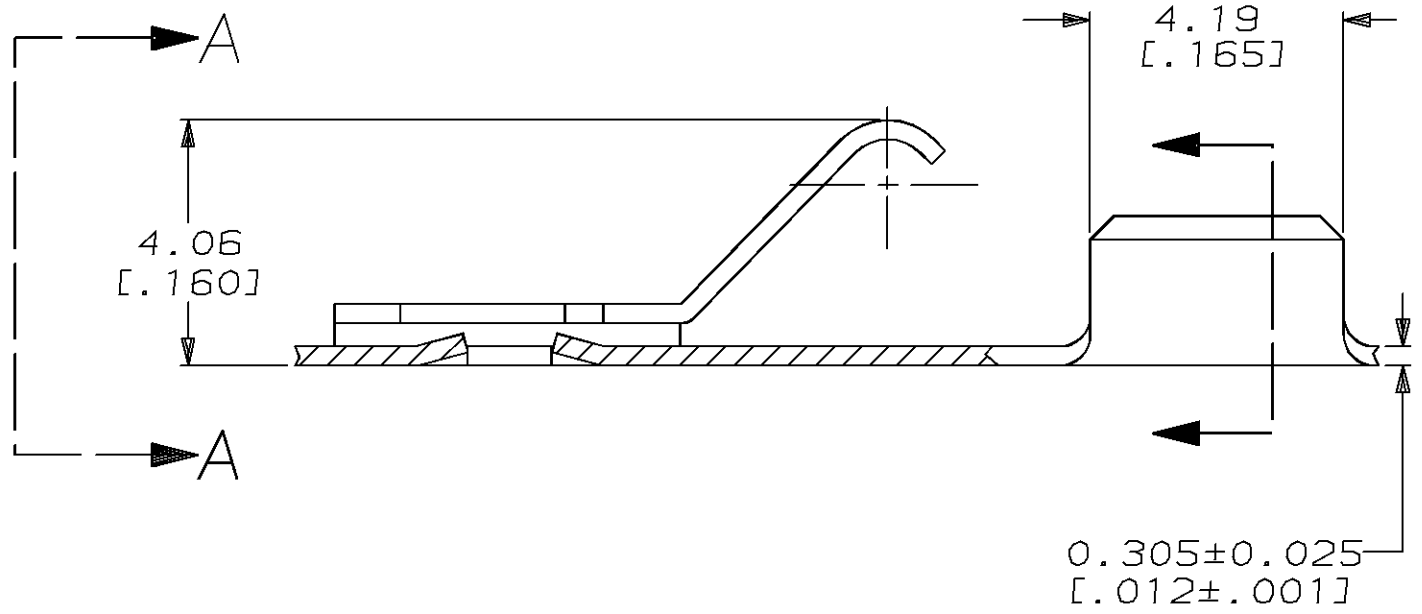
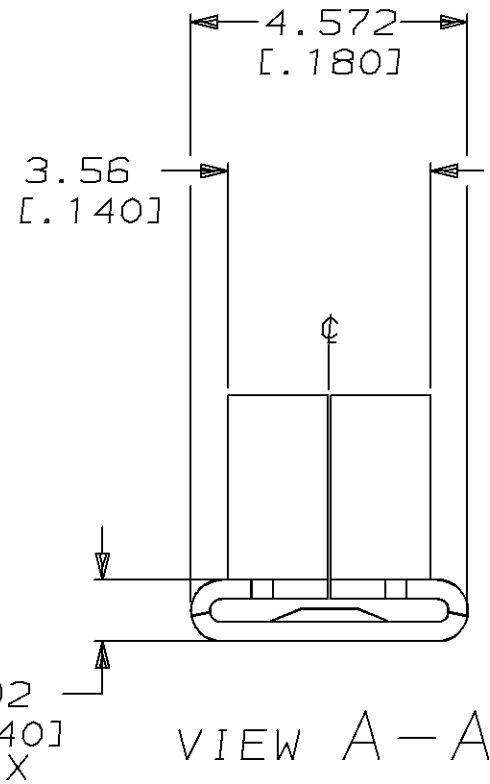

|             |         |
|-------------|---------|
| [22-18] AWG | 63937-1 |
| WIRE RANGE  | PART NO |

|  |                                   |
|--|-----------------------------------|
| DO NOT SCALE PRINT, UNLESS SPECIFIED. DIMENSIONS IN mm [INCHES] TOLERANCES ON:<br>2 PLC DEC ± 0.25 [.010]<br>3 PLC DEC ± -<br>ANGLES ± - | DR 18/SEP/96<br>PHILLIP M FORTNEY |
|  | CHK 18/SEP/96<br>JEFF R RUTH      |
|  | APPD 18/SEP/96<br>DENNIS SCHWENK  |
|  | APPD 18/SEP/96<br>MARK BARNABA    |
|  | PRODUCT SPEC<br>-                 |
| MATERIAL<br>H04 PHOS BRONZE  | APPLICATION SPEC<br>-             |
| FINISH<br>-  | WEIGHT<br>-                       |

|   |                    |                       |
|---|--------------------|-----------------------|
| AMP Incorporated<br>Harrisburg, PA 17105-3608 |                    |                       |
| NAME<br>SPECIAL TERMINAL                      |                    |                       |
| SIZE<br>B                                     | CAGE CODE<br>00779 | DRAWING NO<br>C-63937 |
| SCALE<br>8:1                                  | SHEET<br>1 OF 1    |                       |

THIS DRAWING IS A CONTROLLED DOCUMENT FOR AMP INCORPORATED. IT IS SUBJECT TO CHANGE AND THE CONTROLLING ENGINEERING ORGANIZATION SHOULD BE CONTACTED FOR THE LATEST REVISION.