

SECTION C-C

SECTION D-D

spec ref	-	dr	Chris Gieski	2010/02/26	projection	MM	size	A2	scale	4:1
tolerance std	ASME Y14.5	eng	Wei-Long Zhang	2011/09/19			ecn no	-	rel level	Released
TOLERANCES UNLESS OTHERWISE SPECIFIED		chr	-	product family			CARD EDGE	cat. no.	10116283	rev
surface	✓	appr	Pei-Ming Zheng	2011/09/19	www.fci.com		Product - Customer Drw		sheet 1 of 4	
linear	0.X ±0.3 0.XX ±0.1 0.XXX ±0.05	TITLE		VERTICAL PF RECT(36P-24S) NO PLASTIC PEG HIGH POWER CARD EDGE		PDS: Rev :A		STATUS:Released		Printed: Sep 19, 2011
angular	0° ±2°	cat. no.		-		-		-		-

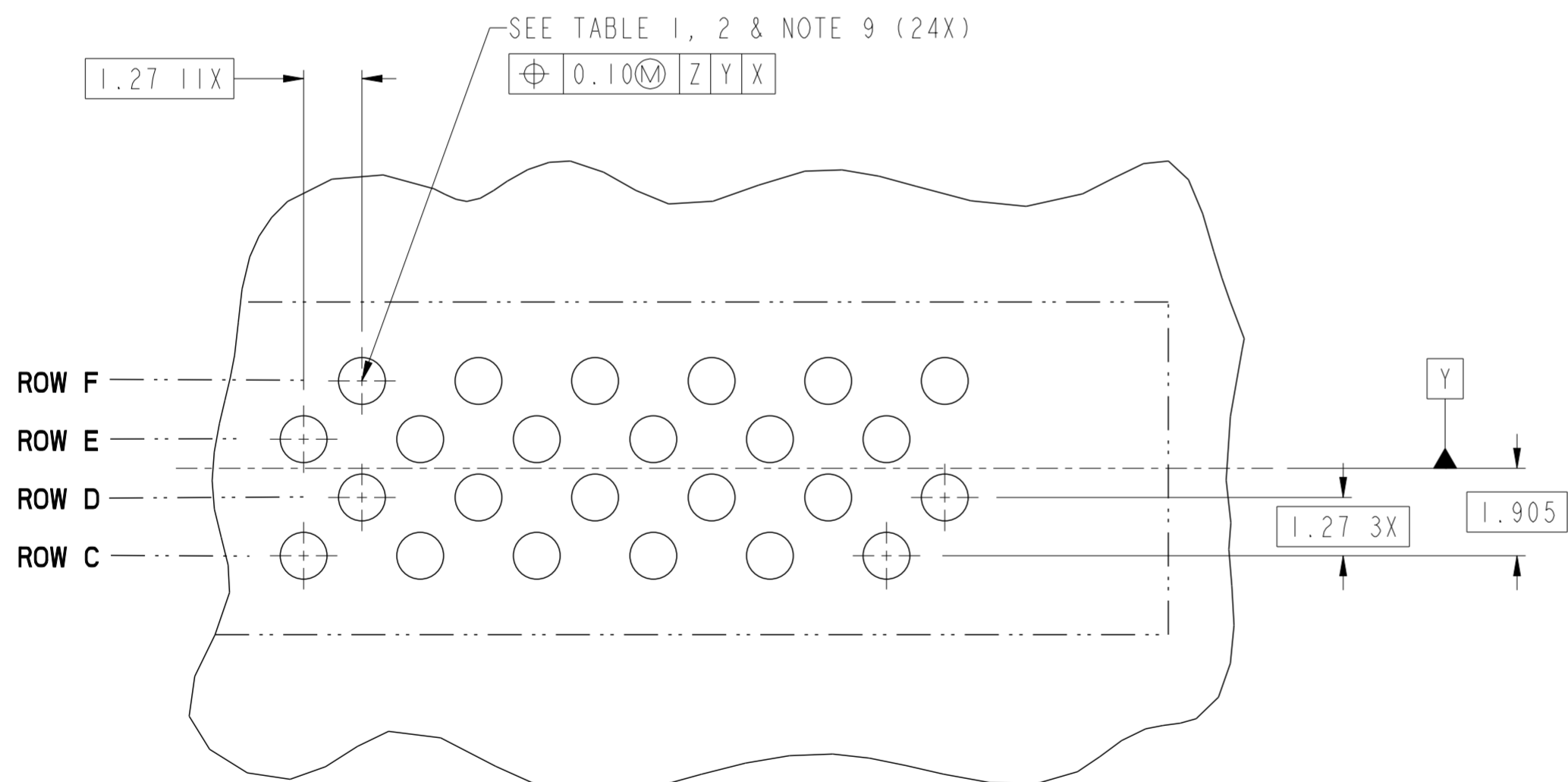
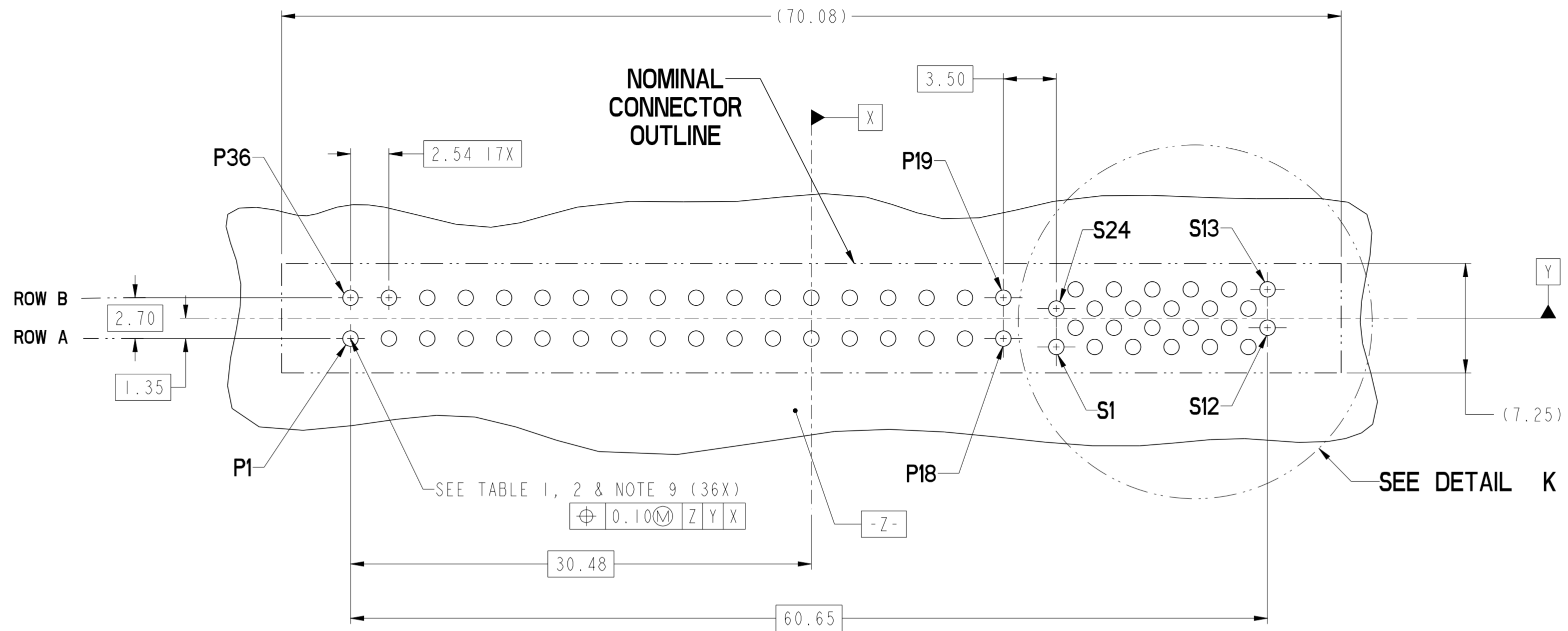

DETAIL K
SCALE 8:1

RECOMMENDED PCB LAYOUT
VIEWED FROM CONNECTOR SIDE

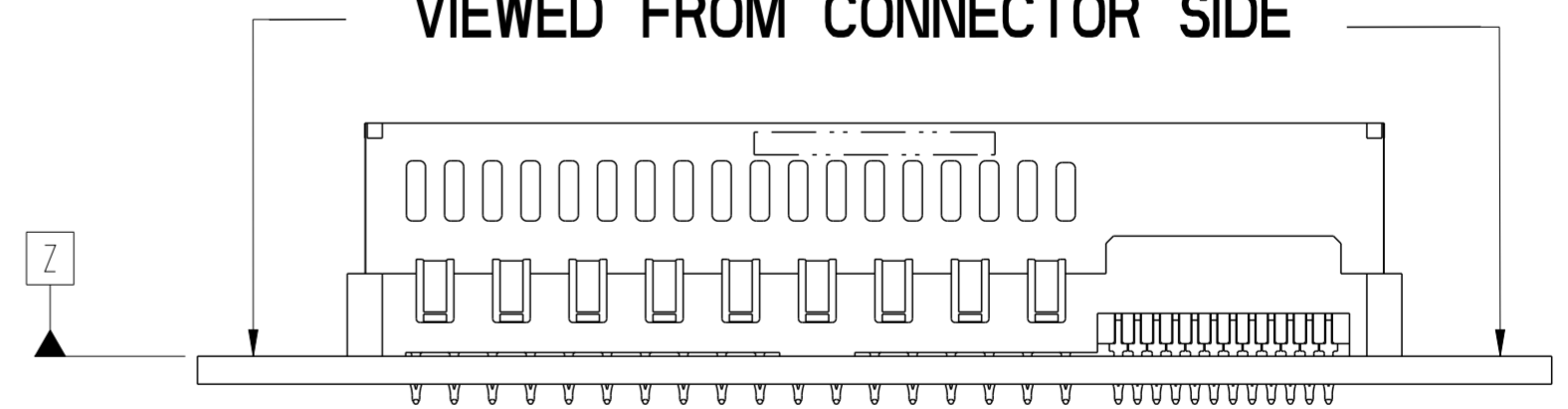

spec ref	-	dr	Chris Gieski	2010/10/26	projection	MM	size	A2	scale	4:1	
tolerance std	ASME Y14.5	eng	Wei-Long Zhang	2011/09/19			ecn no	-	rel level	Released	
TOLERANCES UNLESS OTHERWISE SPECIFIED		chr	-	app			Pai-Ming Zheng	2011/09/19	product family	CARD EDGE	rel level
surface	✓	linear	0.X	±0.3			title	VERTICAL PF RECT(36P-24S) NO PLASTIC PEG		rev	A
			0.XX	±0.1	www.fci.com	cat. no.	-	Product - Customer Drw	sheet 2 of 4		
		angular	0°	±2°							

CONTACT TYPE	TOP LAYER DESCRIPTION	TABLE 1 (HPCE / SOLDER TAILS) PLATED THROUGH-HOLE REQUIREMENTS				
		DRILLED HOLE DIAMETER	COPPER THICKNESS	TIN-LEAD THICKNESS	TIN THICKNESS	FINISHED HOLE DIAMETER
POWER & SIGNAL	TIN-LEAD	1.10-1.16 (1.15 DRILL)	0.025 - 0.050	0.005 - 0.015	--	0.94 - 1.10
	IMMERSION TIN	1.10-1.16 (1.15 DRILL)	0.025 - 0.050	--	0.9 - 1.5um	0.94 - 1.10
	COPPER (SEE NOTE 8)	1.10-1.16 (1.15 DRILL)	0.025 - 0.050	--	--	0.94 - 1.10

CONTACT TYPE	TOP LAYER DESCRIPTION	TABLE 2 (HPCE / PRESS-FIT TAILS) PLATED THROUGH-HOLE REQUIREMENTS				
		DRILLED HOLE DIAMETER	COPPER THICKNESS	TIN-LEAD THICKNESS	TIN THICKNESS	FINISHED HOLE DIAMETER
POWER & SIGNAL	TIN-LEAD	0.81-0.86 (0.85 DRILL)	0.025 - 0.050	0.005 - 0.015	--	0.65 - 0.80
	IMMERSION TIN	0.81-0.86 (0.85 DRILL)	0.025 - 0.050	--	0.9 - 1.5um	0.70 - 0.80
	COPPER (SEE NOTE 8)	0.81-0.86 (0.85 DRILL)	0.025 - 0.050	--	--	0.70 - 0.80

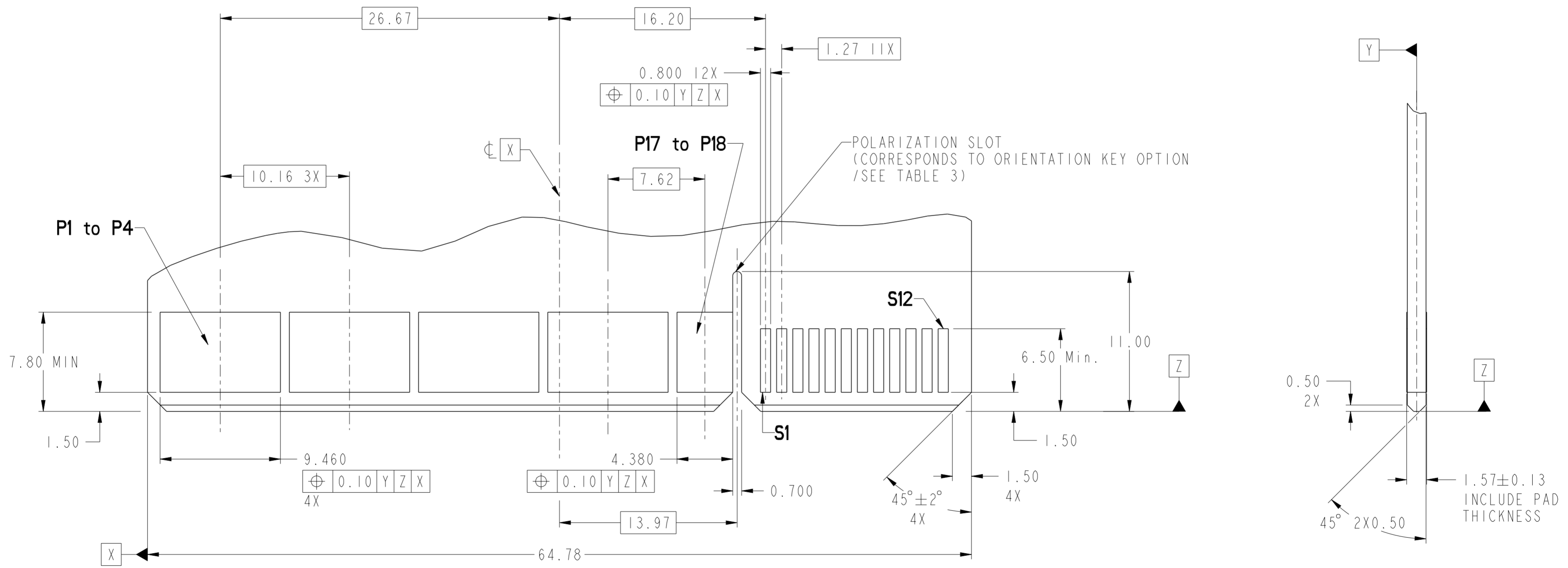

RECOMMENDED MATING BOARD FOOTPRINT

spec ref	-	dr	Chris Gieski	2010/026	projection	MM	size	A2	scale	4:1
tolerance std	ASME Y14.5	eng	Wei-Long Zhang	2011/09/19	chr	-	ecn no	-	rel level	Released
surface	linear	appr	Pei-Ming Zheng	2011/09/19	product family	CARD EDGE	dwg no	10116283	rev	A
ASME Y14.5	angular	0°	±2°	www.fci.com	cat. no.	-	Product - Customer Drw	sheet 3 of 4		

Copyright FCI. FCI

HPCE PART NUMBER (TABLE 3)

PART NUMBER	TAIL TYPE	ORIENTATION KEY	DIM "A" TYPICAL TAIL LENGTH	DIM "B" RECOMMENDED BOARD THICKNESS
10116283-003	PRESS-FIT	YES	3.17 ±0.25	1.57 MIN
10116283-003LF	PRESS-FIT	YES		
10116283-004	PRESS-FIT	NO		
10116283-004LF	PRESS-FIT	NO		

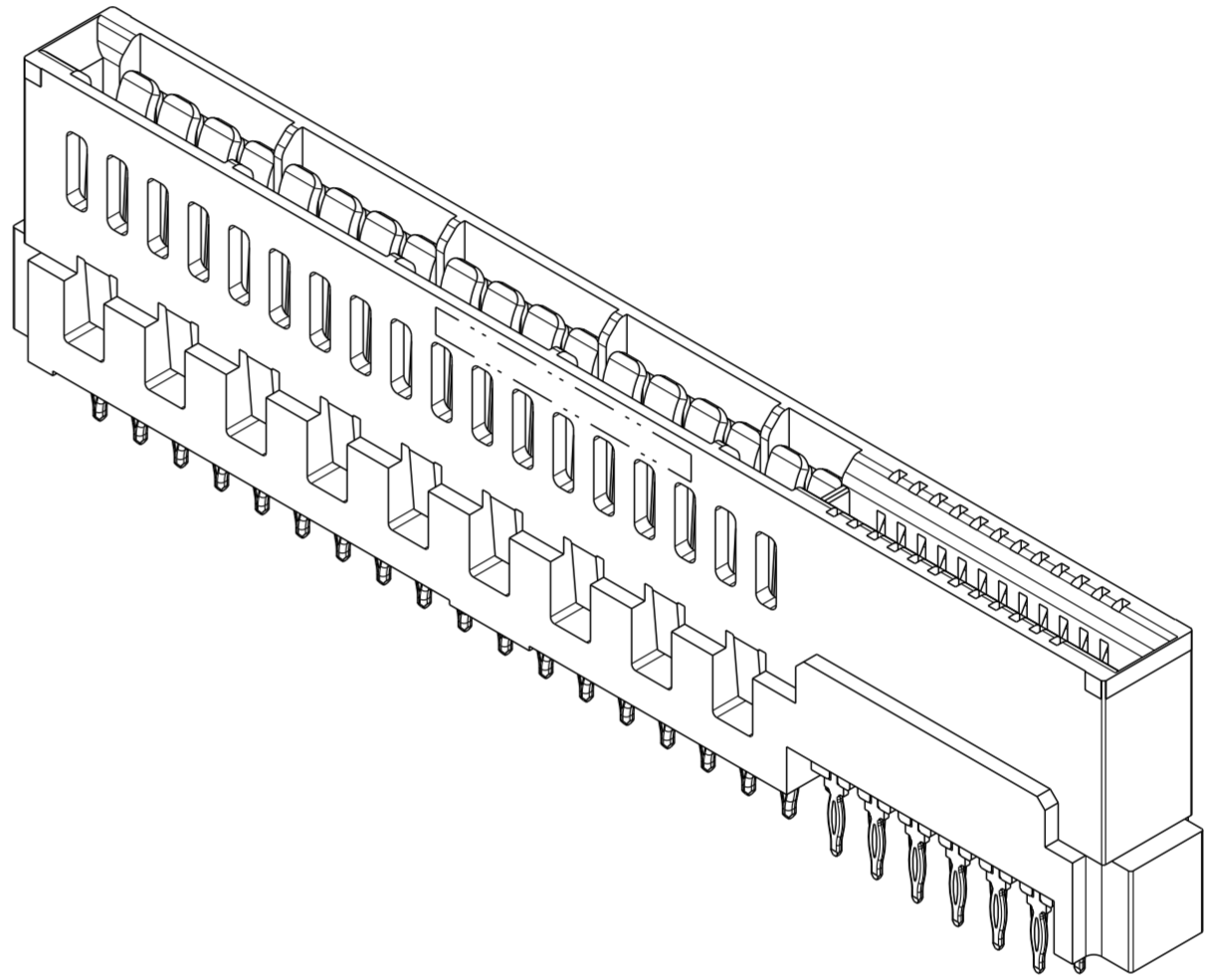

NOTES:

1. CONNECTOR MATERIALS:
 HOUSING: HIGH TEMPERATURE THERMO PLASTIC, BLACK
 UL 94V-0 COMPLIANT
 CONTACTS: HIGH PERFORMANCE COPPER ALLOY.
2. CONTACT FINISH REF. GS-12-604 SECTION 5.2.
3. PRODUCT SPECIFICATION: GS-12-604.
4. APPLICATION SPECIFICATION: GS-20-128.
5. PRODUCT MARKING (FCI - PART NUMBER & DATE CODE) ON HOUSING IN AREA SHOWN.
6. PACKAGING MEETS FCI SPECIFICATION GS-14-937.
7. HOUSING COMPONENT WILL WITHSTAND EXPOSURE TO 260°C PEAK TEMPERATURE FOR 60 SECONDS IN A CONVECTION, INFRA-RED, OR VAPOR PHASE REFLOW OVEN.
8. COPPER PLATING THICKNESS IN CENTER OF VIA-HOLE CAN BE NO MORE THAN 0.003 LESS THAN OTHER AREAS.
9. ALL HOLE SIZES ARE FINISHED HOLE SIZES.
10. MOUNTING HOLES ARE UNPLATED
 Ø 2.40 +/- 0.1 FOR PRESS-FIT TAILS
 Ø 2.10 +/- 0.1 FOR SOLDER TAILS

spec ref	-	dr	Chris Gieski	2010/10/26	projection	MM	size	A2	scale	4:1	
tolerance std	ASME Y14.5	eng	Wei-Long Zhang	2011/09/19			ecn no	-	rel level	Released	
surface	✓	chr	-	product family			CARD EDGE	cat. no.	10116283	rev	A
ASME Y14.5	linear	appr	Pei-Ming Zheng	2011/09/19			www.fci.com	Product - Customer Drw	sheet 4 of 4		
	angular										

Copyright FCI. FCI