

Getting started with the X-NUCLEO-IHM17M1 low voltage 3-phase brushless DC motor driver expansion board based on STSPIN233

Introduction

The **X-NUCLEO-IHM17M1** is a low voltage three-phase brushless DC motor driver expansion board based on **STSPIN233** for **STM32 Nucleo**. It is an affordable and easy-to-use solution with motor driver operation in low voltage battery scenarios, allowing zero consumption state (such as in thermal printers, robotics, toys, etc..).

The **X-NUCLEO-IHM17M1** supports the addition of other boards to a single STM32 Nucleo board through the Arduino UNO R3 and the ST morpho connectors.

Furthermore, the board is designed for six-step and FOC algorithms.

Figure 1. X-NUCLEO-IHM17M1 expansion board

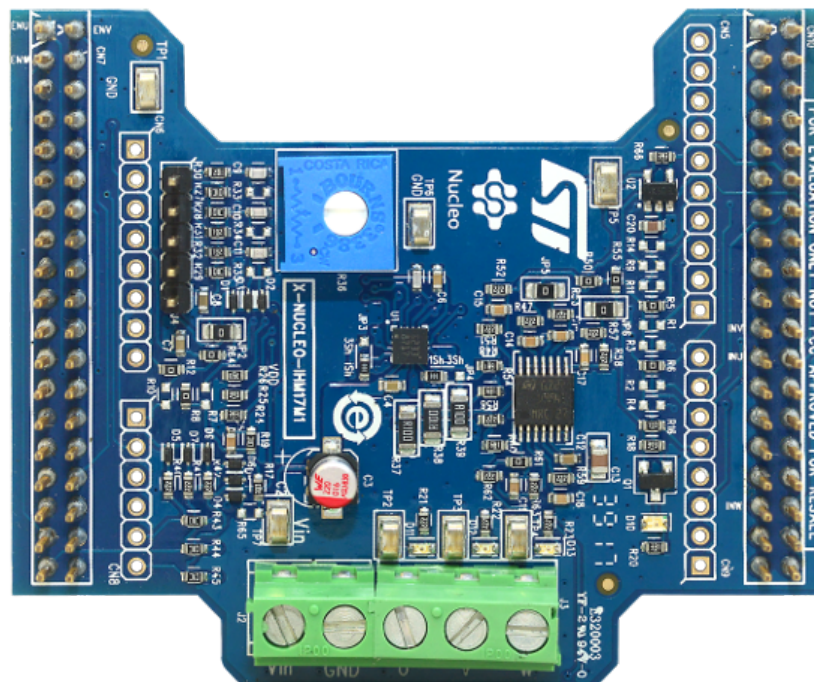

1 Hardware and software requirements

To use the [STM32 Nucleo](#) development boards with the [X-NUCLEO-IHM17M1](#) expansion board, the following software and hardware are required:

- a Windows PC (XP, Vista 7 , Win 8, Win 10) to install the software package
- an [X-NUCLEO-IHM17M1](#) expansion board
- an STM32 Nucleo development board ([NUCLEO-F030R8](#), [NUCLEO-F103RB](#), [NUCLEO-F302R8](#) or [NUCLEO-F401RE](#))
- a type A USB to mini-B USB cable to connect the STM32 Nucleo board to the PC
- the [X-CUBE-SPN17](#) software package (available on www.st.com)
- an IDE chosen among IAR Embedded Workbench for ARM ([IAR-EWARM](#)), Keil microcontroller development kit ([MDK-ARM-STM32](#)) and system workbench for STM32 Nucleo project ([SW4STM32](#))
- three-phase brushless DC motor with compatible voltage and current for [STSPIN233](#) driver
- an external power supply or battery able to provide the voltage required by the brushless motor used

2 Getting started

The [X-NUCLEO-IHM17M1](#) expansion board is a three-phase brushless DC motor driver covering a wide range of applications.

The board maximum ratings are:

- Power stage supply voltage from 1.8 to 10 V
- Motor phase current up to 1.3 A_{rms}

To start your project with the board:

- Procedure**
- Step 1.** Check the jumper position of your configuration (see [Section 3 Hardware description and configuration](#))
 - Step 2.** Connect the [X-NUCLEO-IHM17M1](#) with the [STM32 Nucleo](#) development board through ST morpho connectors (CN7, CN10)
 - Step 3.** Supply the board through input 2 (Vin) and 1 (GND) of the J2 connector: the D10 (red) LED turns on
 - Step 4.** Develop your application using the examples provided with the firmware library
Further support material is available at [STSPIN233](#) and [STM32 Nucleo](#)

3 Hardware description and configuration

The figure below shows the board connector and jumper positions.

Figure 2. X-NUCLEO-IHM17M1 jumper and connector positions

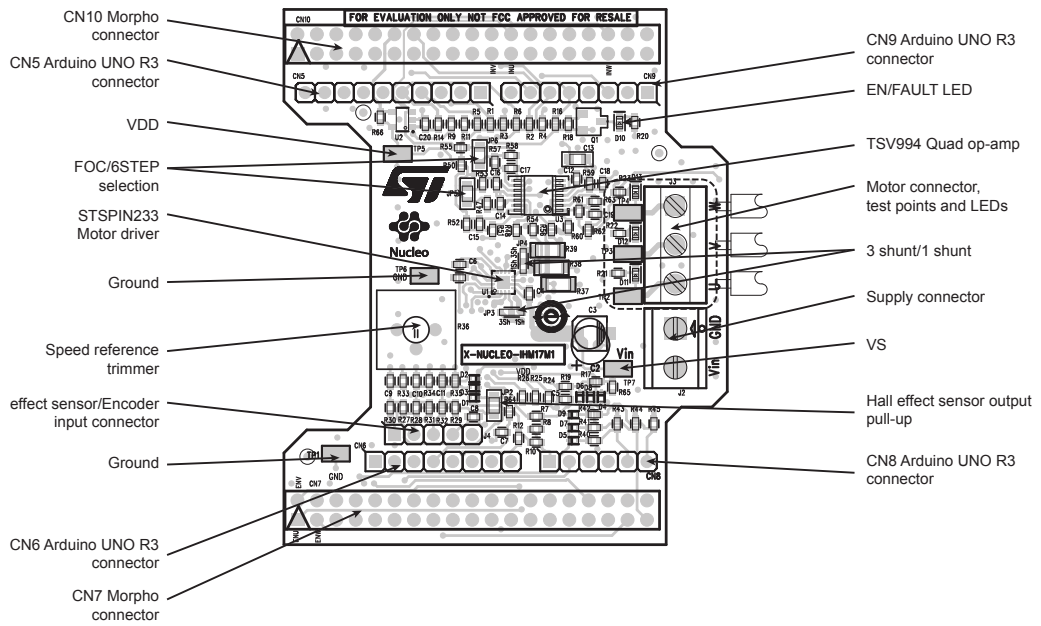

The table below shows ST morpho connector detailed pinout.

Table 1. ST morpho connectors

Connector	Pin ⁽¹⁾	Signal	Remarks
CN7	1	Enable 1	ENU input
	2	Enable 2	ENV input
	3	Enable 3	ENW input
	12	VDD	
	16	VDD	
	17	H1/Encoder A	Mounting option R12 (default)
	18	5 V	
	20	Ground	
	22	Ground	
	28	H1/Encoder A	Mounting option R10
		Bus voltage feedback	Mounting option R8
	30	H2/Encoder B	
	32	Current reference	Mounting option R9
	34	Current feedback 3	
	35	SPEED reference	
	36	BEMF sensing 1	
	37	BEMF sensing 2	
	38	BEMF sensing 3	
CN10	1	BEMF GPIO	Enable/disable voltage divider
	12	Stop PWM (ETR)	
	13	Current reference	Mounting option R14
		EN/FAULT	Mounting option R6
	14	EN/FAULT	Mounting option R2
	15	Current feedback 1	Mounting option R5 (default)
	16	Current feedback 1	Mounting option R1
	21	IN2	INV input
	23	IN1	INU input
	24	Current feedback 2	
	25	H3/Encoder Z	
	26	Current feedback 1	Mounting option R3
	27	Current reference	Mounting option R11 (default)
	28	EN/FAULT	Mounting option R4
	29	Standby	
	33	IN3	INW input
	34	Bus voltage feedback	Mounting option R7

1. All the non-listed pins are not connected

The **X-NUCLEO-IHM17M1** is equipped with screw connectors for motor and power supply, jumpers for selecting the single-shunt or three-shunt operation and a connector for Hall effect sensors (refer to the table below).

Table 2. Other connectors, jumpers and test points

Reference	Pins	Label	Description
J2	1, 2	Vin – GND	Supply voltage
J3	1, 2, 3	U – V – W	Motor phases
J4	1, 2, 3	-	Hall effect sensor/Encoder inputs
JP2	1, 2		Hall effect sensor pull-up
JP3	1, 2, 3	3 Sh – 1 Sh	Three shunt/single shunt topology
JP4	1, 2, 3	3 Sh – 1 Sh	Three shunt/single shunt topology
JP5	1, 2		FOC/6STEP configuration
JP6	1, 2		FOC/6STEP configuration
TP1		GND	Ground
TP2			OUT U test point
TP3			OUT V test point
TP4			OUT W test point
TP5			VDD test point
TP6		GND	Ground
TP7		VS	Supply voltage test point

3.1 Selecting the STM32 Nucleo board

This expansion board natively supports the following [STM32 Nucleo](#) development boards:

- [NUCLEO-F401RE](#)
- [NUCLEO-F302R8](#)
- [NUCLEO-F103RB](#)
- [NUCLEO-F030R8](#)

Before starting to work with the development board, check if the proper mounting option is implemented (see [Section 5 Mounting options](#)).

4 Circuit description

The [STSPIN233](#) integrates a protected triple half-bridge with low $R_{DS(on)}$ for evaluating a solution for a three-phase BLDC motor in very low consumption mode.

The device is protected against overload and short-circuits: short to ground, short to motor supply voltage, short between the outputs. If one of the failure events occurs, the fault signal is set and the fault LED D10 is lit (red).

The [STSPIN233](#) is compatible with single and three-shunt sensing, and the [X-NUCLEO-IHM17M1](#) expansion board is designed to provide both topologies. The current feedback signal conditioning is performed by hardware available on the board and sent to the STM32 Nucleo board through the ST morpho connectors.

Motor speed regulation can be performed by hardware, by acting on trimmer R36. In this way, you can change the reference used by STM32 firmware for speed regulation.

The [X-NUCLEO-IHM17M1](#) expansion board provides two hardware solutions for motor position feedback: one based on sensors and the other one based on sensorless detection.

4.1 Hall/encoder motor speed sensor

The [X-NUCLEO-IHM17M1](#) expansion board implements the Hall/encoder sensor detection circuit for motor speed feedback. The motor sensor feedback is connected through the J4 connector and an analog circuit to the STM32 Nucleo board in order to detect the motor rotation.

For sensors requiring external pull-up, three 10 k Ω resistors are already mounted and connected to the VDD voltage (if these are not necessary, you can remove them).

4.2 Sensorless detection

In six-step driving mode, one of the three phases is left in high impedance state: comparing this phase voltage with the center-tap voltage, we can detect the BEMF zero-crossing.

This signal is acquired through an analog circuit embedded on the expansion board and sent to the STM32 Nucleo board through the ST morpho connectors.

4.3 Bus voltage circuit

The [X-NUCLEO-IHM17M1](#) expansion board provides the hardware bus voltage sensing. This signal is acquired with a resistor divider from the motor supply voltage (VBUS) and sent to the analog to digital converter.

5 Mounting options

The X-NUCLEO-IHM17M1 provides different mounting options to be compatible with the following STM32 Nucleo development boards:

- [NUCLEO-F401RE](#)
- [NUCLEO-F302R8](#)
- [NUCLEO-F103RB](#)
- [NUCLEO-F030R8](#)

Table 3. Mounting options

Board	Curr fbk 1			Curr ref			VBUS fbk		EN/FAULT			Enc. A/H1	
	R1	R3	R5	R9	R11	R14	R7	R8	R2	R4	R6	R10	R12
NUCLEO-F401RE (default)	NM	NM	0R	NM	22k	NM	NM	0R	NM	NM	0R	NM	0R
NUCLEO-F302R8	NM	0R	NM	NM	NM	22k	NM	0R	NM	0R	NM	NM	0R
NUCLEO-F103RB	NM	NM	0R	NM	NM	NM	0R	NM	NM	NM	0R	0R	NM
NUCLEO-F030R8	NM	NM	0R	NM	NM	NM	NM	0R	NM	NM	0R	NM	0R

6 Bill of materials

Table 4. X-NUCLEO-IHM17M1 bill of materials

Item	Q.ty	Ref.	Part/Value	Description	Manufacturer	Order code
1	1	CN5	NP	Header	Samtec	SSQ-110-01-F-S
2	2	CN6, CN9	NP	Header	Samtec	SSQ-108-01-F-S
3	2	CN7, CN10	ESQ-119-24-G-D	Header	Samtec	ESQ-119-24-G-D
4	1	CN8	NP	Header	Samtec	SSQ-106-01-F-S
5	1	C1	1 nF 50 V 0.15 603	Cercamic capacitor	Any	1NF_50V_X5R_0603
6	1	C2	22 µF 16 V 0.2 D5_H11_P2	Aluminium capacitor	Wurth Elektronik	860010372002
7	1	C3	22 µF 16 V 0.2 L4.5_W4.5	Aluminium capacitor	Wurth Elektronik	865080340003
8	1	C4	2.2 µF 16 V 0.2 603	Cercamic capacitor	Any	2.2µF_16V_X5R_0603
9	7	C5, C14, C15, C16, C17, C18, C19	680 pF 50 V 0.15 603	Cercamic capacitor	Any	680PF_50V_X7R_0603
10	1	C6	10 nF 50 V 0.15 603	Cercamic capacitor	Any	10NF_50V_X7R_0603
11	1	C7	3.3 nF 50 V 0.15 603	Cercamic capacitor	Any	3.3NF_50V_X7R_0603
12	2	C8, C12	100 nF 50 V 0.15 603	Cercamic capacitor	Any	100NF_50V_X7R_0603
13	3	C9, C10, C11	10 pF 50 V 0.1 603	Cercamic capacitor	Any	10PF_50V_COG_0603
14	1	C13	4.7 µF 50 V 0.15 805	Cercamic capacitor	Any	4.7µF_50V_X7R_0805
15	1	C20	220 nF 50 V 0.1 603	Cercamic capacitor	Any	220NF_50V_X7R_0603
16	9	D1, D2, D3, D4, D5, D6, D7, D8, D9	BAT30KFILM SOD523	Small signal Schottky diode	ST	BAT30KFILM
17	1	D10	603	Red LED	Wurth Elektronik	150060RS75000
18	3	D11, D12, D13	603	Yellow LED	Wurth Elektronik	150060YS75000
19	1	JP2	Tin-drop close 805	Resistor	Any	Any
20	2	JP5, JP6	Tin-drop open 805	Resistors	Any	Any
21	2	JP3, JP4	Tin-drop dual 603	Resistors	Any	Any
22	1	J2		Screw	Wurth Elektronik	691213510002
23	1	J3		Screw	Wurth Elektronik	691213510003

Item	Q.ty	Ref.	Part/Value	Description	Manufacturer	Order code
24	1	J4		Header	Wurth Elektronik	61300511121
25	1	M8	PCB GY rev1 - 2 layers	PCB	Any	Any
26	1	Q1	P-MOS SOT23	CMS	Fairchild Semiconductors	FDV302P
27	8	R1, R2, R3, R4, R7, R9, R10, R65	NP 603	Resistors	Any	R_NP_0603
28	8	R5,R6,R8,R12, R50,R55,R61,R64	0 R 1/10 W ±5% 603	Resistors	Any	0R_5%_0603
29	1	R11	22 K 1/10 W ±5% 603	Resistor	Any	22K_5%_0603
30	1	R14	22 K (NP) 1/10 W ±5% 603	Resistor	Any	22K_5%_0603
31	1	R16	18 K 1/10 W ±5% 603	Resistor	Any	18K_5%_0603
32	1	R17	30 K 1/10 W ±1% 603	Resistor	Any	30K_1%_0603
33	5	R18, R24, R25, R26, R66	39 K 1/10 W ±5% 603	Resistors	Any	39K_5%_0603
34	1	R19	10 K 1/10 W ±1% 603	Resistor	Any	10.0K_1%_0603
35	1	R20	330 R 1/10 W ±5% 603	Resistor	Any	330R_5%_0603
36	16	R21, R22, R23, R40, R41, R42, R47, R51, R52, R53, R56, R57, R58, R59, R62, R63	2.2 K 1/10 W ±5% 603	Resistors	Any	2.2K_5%_0603
37	6	R27, R28, R29, R43, R44, R45	10 K 1/10 W ±5% 603	Resistors	Any	10K_5%_0603
38	3	R30, R31, R32	1.8 K 1/10 W ±5% 603	Resistors	Any	1.8K_5%_0603
39	3	R33, R34, R35	NP 1/10 W ±5% 603	Resistors	Any	4.7K_5%_0603
40	1	R36	100 K 1/2 W ±10% L9.5_W4.9_H9.5	Trimmer resistor	Bourns	3386P-1-104
41	3	R37, R38, R39	0.1 R 1/2 W ±1% 1206	Resistors	Any	0.1R_1%_1206_0.5W
42	3	R48, R54, R60	680 R 1/10 W ±5% 603	Resistors	Any	680R_5%_0603
43	7	TP1, TP2, TP3, TP4, TP5, TP6, TP7	S1751-46R	Test points	Harwin	S1751-46R
44	1	U1	STSPIN233 QFN16	Low voltage three phase and three sense motor driver	ST	STSPIN233

Item	Q.ty	Ref.	Part/Value	Description	Manufacturer	Order code
45	1	U2	LMV331 SOT23-5L	General purpose low voltage comparator	ST	LMV331ILT
46	1	U3	TSV994 TSSOP14	Wide bandwidth (20MHz) rail to rail input/ output 5V CMOS Op- Amps, quad	ST	TSV994IPT

7 X-NUCLEO-IHM17M1 schematic diagram

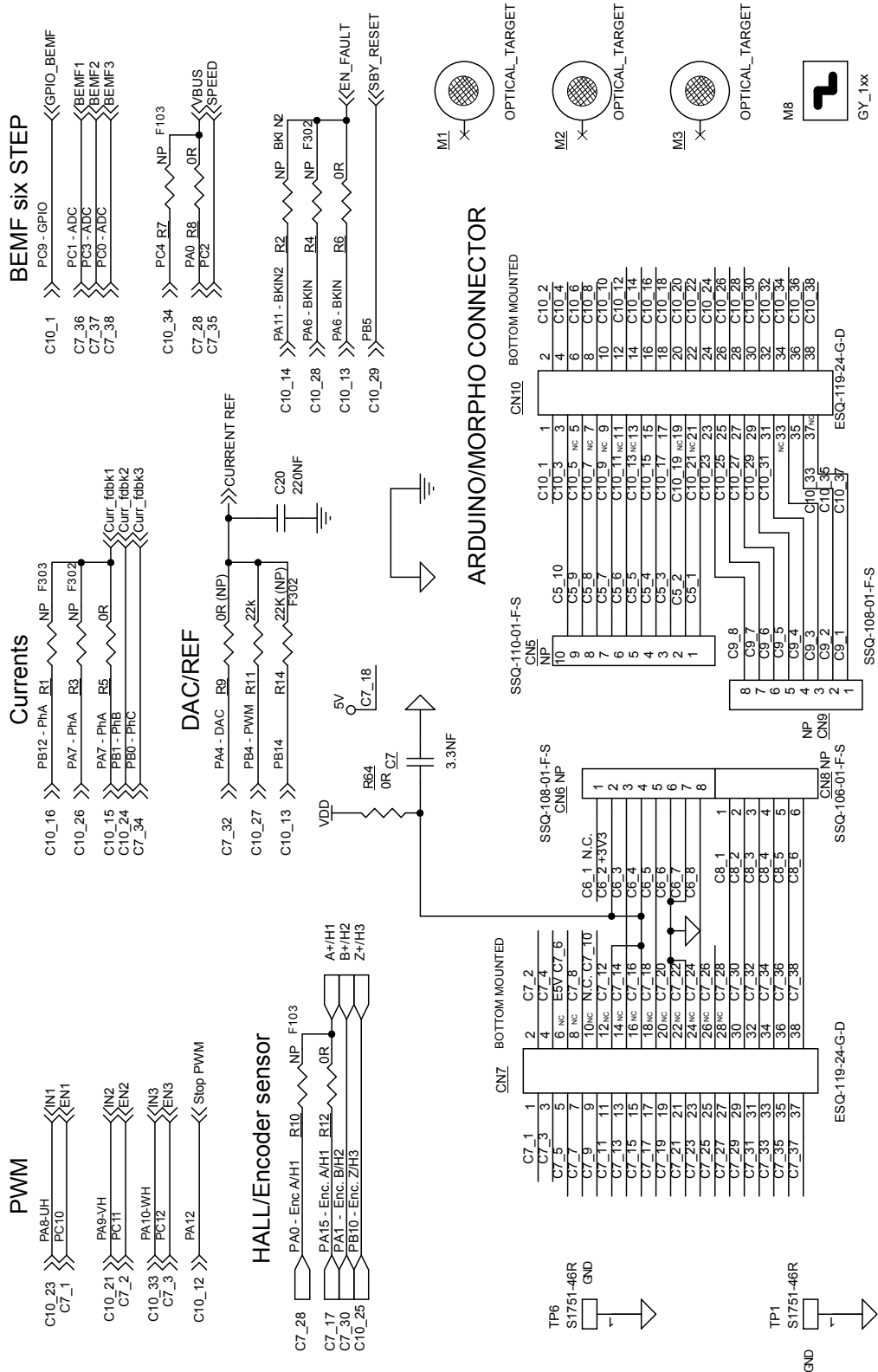
Figure 3. X-NUCLEO-IHM17M1 circuit schematic (1 of 2)

Revision history

Table 5. Document revision history

Date	Revision	Changes
09-Feb-2018	1	Initial release.

Contents

1	Hardware and software requirements	2
2	Getting started	3
3	Hardware description and configuration	4
3.1	Selecting the STM32 Nucleo board	6
4	Circuit description	7
4.1	Hall/encoder motor speed sensor	7
4.2	Sensorless detection	7
4.3	Bus voltage circuit	7
5	Mounting options	8
6	Bill of materials	9
7	X-NUCLEO-IHM17M1 schematic diagram	12
	Revision history	14

List of tables

Table 1.	ST morpho connectors	5
Table 2.	Other connectors, jumpers and test points.	6
Table 3.	Mounting options	8
Table 4.	X-NUCLEO-IHM17M1 bill of materials	9
Table 5.	Document revision history	14

List of figures

Figure 1.	X-NUCLEO-IHM17M1 expansion board	1
Figure 2.	X-NUCLEO-IHM17M1 jumper and connector positions	4
Figure 3.	X-NUCLEO-IHM17M1 circuit schematic (1 of 2)	12
Figure 4.	X-NUCLEO-IHM17M1 circuit schematic (2 of 2)	13

IMPORTANT NOTICE – PLEASE READ CAREFULLY

STMicroelectronics NV and its subsidiaries (“ST”) reserve the right to make changes, corrections, enhancements, modifications, and improvements to ST products and/or to this document at any time without notice. Purchasers should obtain the latest relevant information on ST products before placing orders. ST products are sold pursuant to ST’s terms and conditions of sale in place at the time of order acknowledgement.

Purchasers are solely responsible for the choice, selection, and use of ST products and ST assumes no liability for application assistance or the design of Purchasers’ products.

No license, express or implied, to any intellectual property right is granted by ST herein.

Resale of ST products with provisions different from the information set forth herein shall void any warranty granted by ST for such product.

ST and the ST logo are trademarks of ST. All other product or service names are the property of their respective owners.

Information in this document supersedes and replaces information previously supplied in any prior versions of this document.

© 2018 STMicroelectronics – All rights reserved