

NOTES:

1. METAL: PHOSPHOR BRONZE.
2. PLATING: OVERALL MATTE TIN MIN 1.0 MICRONS OVER NICKEL MIN 1.0 MICRONS UNDERCOAT
3. PACKAGING: REEL-2004490001PK.
4. THE MAXIMUM DIAMETER OF WIRE SHALL NOT EXCEED 1.40mm.
5. PARTS CONFORMS THE CLASS B REQUIREMENT OF THE MOLEX COSMETIC SPEC PS-45499-002.
6. PRODUCT SPECIFICATION: 2008900001PS
7. PARTS MATES WITH EDGELOCK HOUSING-200890 SERIES
8. DURING HARNESS ASSEMBLY PROPER CARE MUST BE TAKEN TO PROTECT TERMINAL LANCING AREA.

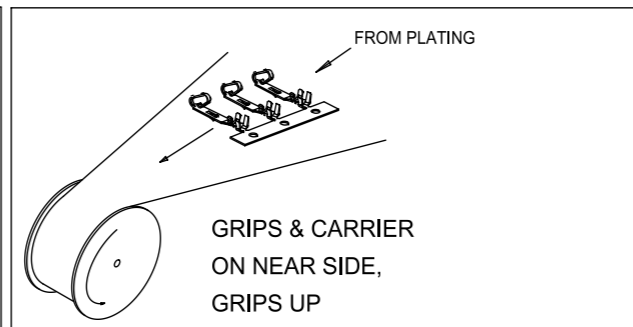
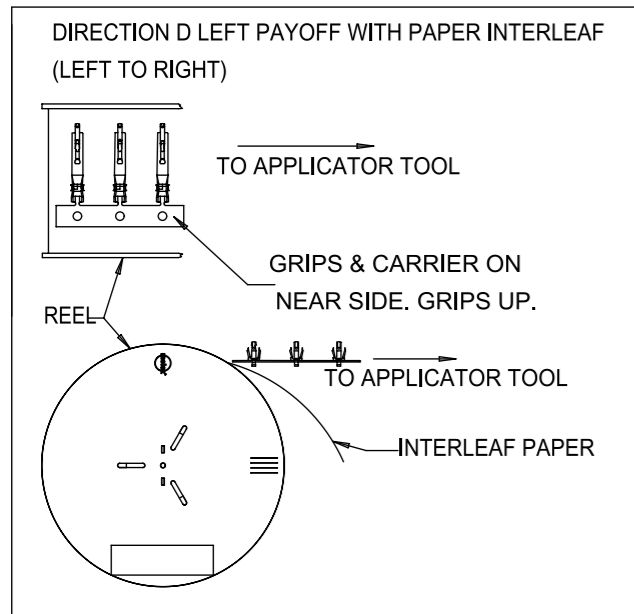

QUALITY SYMBOLS ▽ = 0 ▽ = 0 ▽ = 0 ▼ = 0 ▽ = 0 ⊠ = 0 ■ = 0 ▽ = 0	THIS DRAWING CONTAINS INFORMATION THAT IS PROPRIETARY TO MOLEX INCORPORATED AND SHOULD NOT BE USED WITHOUT WRITTEN PERMISSION										
	EC DESCRIPTION EC NO: 123177 DRWN: SCHONG03 CHK'D: SHCHU APPR: YSKIM02	2017/09/26	2017/10/23	2017/10/23	GENERAL TOLERANCES (UNLESS SPECIFIED)		DIMENSION UNITS	SCALE			
		ANGULAR TOL ± 0.5 °		mm	10:1						
		4 PLACES ±	DRWN BY		DATE		EDGELOCK CRIMP TERMINAL 24AWG UL1061 STYLE				
		3 PLACES ±	GB	2015/07/01							
		2 PLACES ± 0.25	CHK'D BY		DATE		PRODUCT CUSTOMER DRAWING				
	1 PLACE ± 0.38	SHCHU	2017/10/23								
	0 PLACES ±	APPR BY		DATE		SERIES	MATERIAL NUMBER	CUSTOMER			
	DRAFT WHERE APPLICABLE MUST REMAIN WITHIN DIMENSIONS		KPRASAD		2015/09/15		200449	2004490001			
	A3		THIRD ANGLE PROJECTION		DRAWING SIZE		DOCUMENT NUMBER		DOC TYPE	DOC PART	SHEET NUMBER
						2004490001		PSD	000	1 OF 2	