

NO.

CODE

C/M

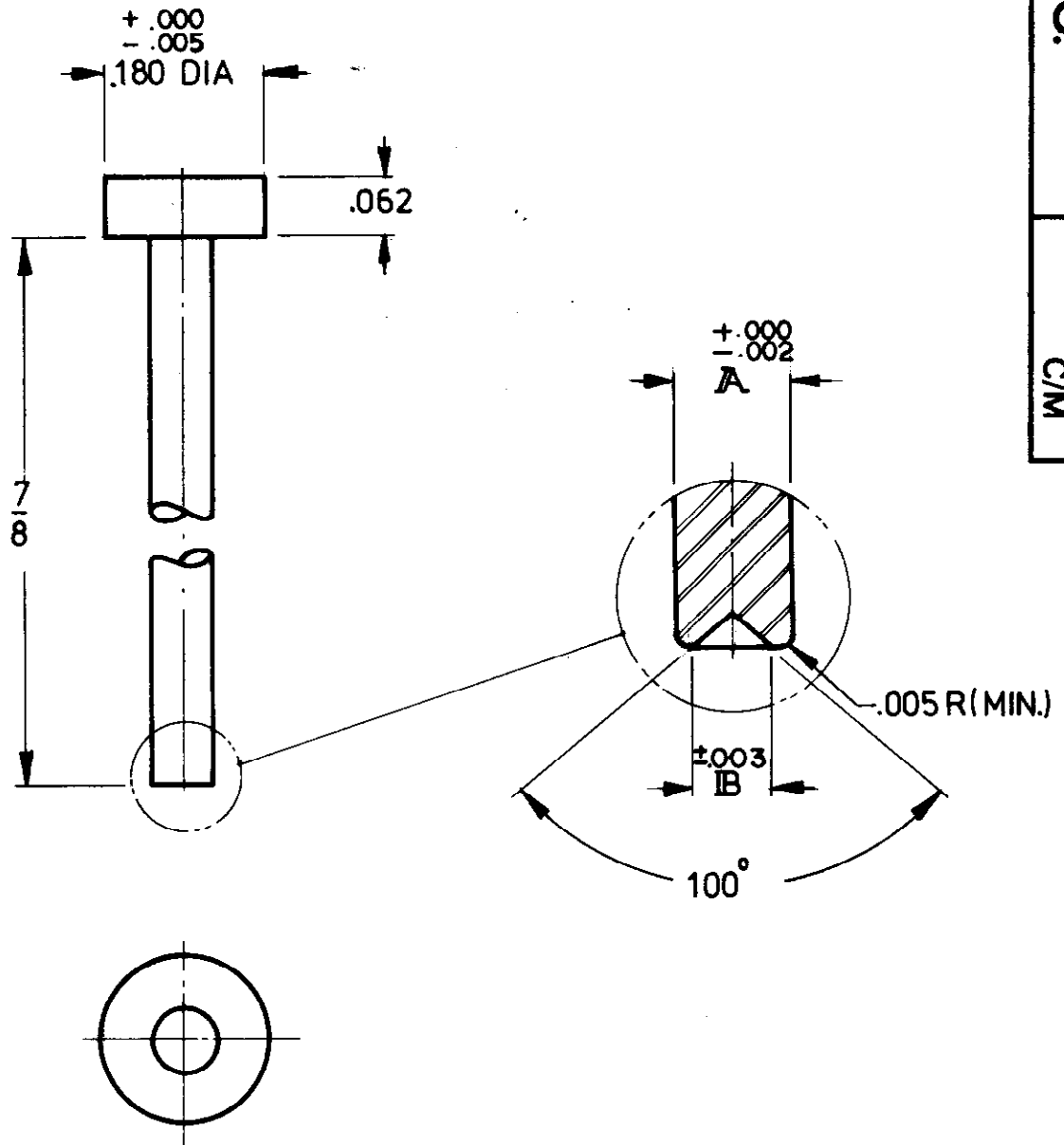

NOTE:

HEAT TREAT TO ROCK C 52-56
 BLACK OXIDE
 BREAK ALL SHARP EDGES

P/No.	A	IB
1315	.045	.038
1316	.069	.055

KEYSTONE ELECTRONICS CORP.

ASTORIA, N.Y. 11105-2017

PART NAME RECEDING PIN		
MATERIAL SAE (W1) DRILL ROD		
FINISH AS NOTED	DRAWN BY LN	DATE 8 12 83
	APPROVED AA	SCALE _____
TOLERANCES FRACTIONAL ± .015 DECIMAL ± .005 ANGULAR ± UNLESS OTHERWISE NOTED		DWG. NO. 1315 - 1316

9.16.94 CHANGE PER ECR 94-054

A

DATE

REVISION

ISSUE