

4 3 2 1
 DRAWING MADE IN THIRD ANGLE PROJECTION
 THIS DRAWING IS UNPUBLISHED. RELEASED FOR PUBLICATION .19
 © COPYRIGHT 19 BY AMP INCORPORATED. ALL INTERNATIONAL RIGHTS RESERVED.

| LOC | DIST | P | F | ZONE | LTR | REVISIONS | DATE | APPD |
|-----|------|---|---|------|-----|--------------------------|---------|------|
| G | 14 | | | | A | REVISED PER 0720-0230-93 | 2/28/94 | DAP |

METRIC
 DIMENSIONS LISTED IN mm [INCHES]

| | |
|----------------------------|----------------------------|
| AMP WIRE RANGE | UL E13288 Listed |
| 12-10 AWG STRANDED | 12-10 AWG STRANDED |
| LR7189 Certified | MILITARY P/N AND CLASS |
| NOT CERTIFIED | NOT APPLICABLE |

△ STAMP AMP 12-10* APPROX AS SHOWN

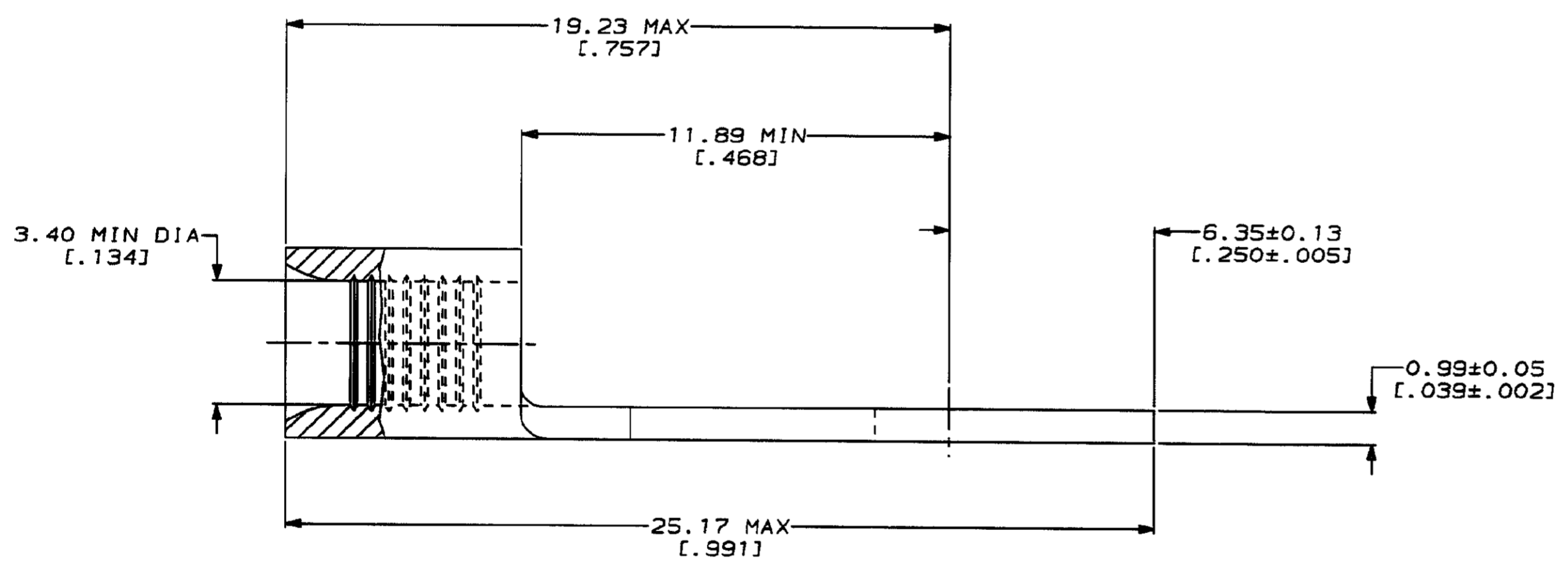
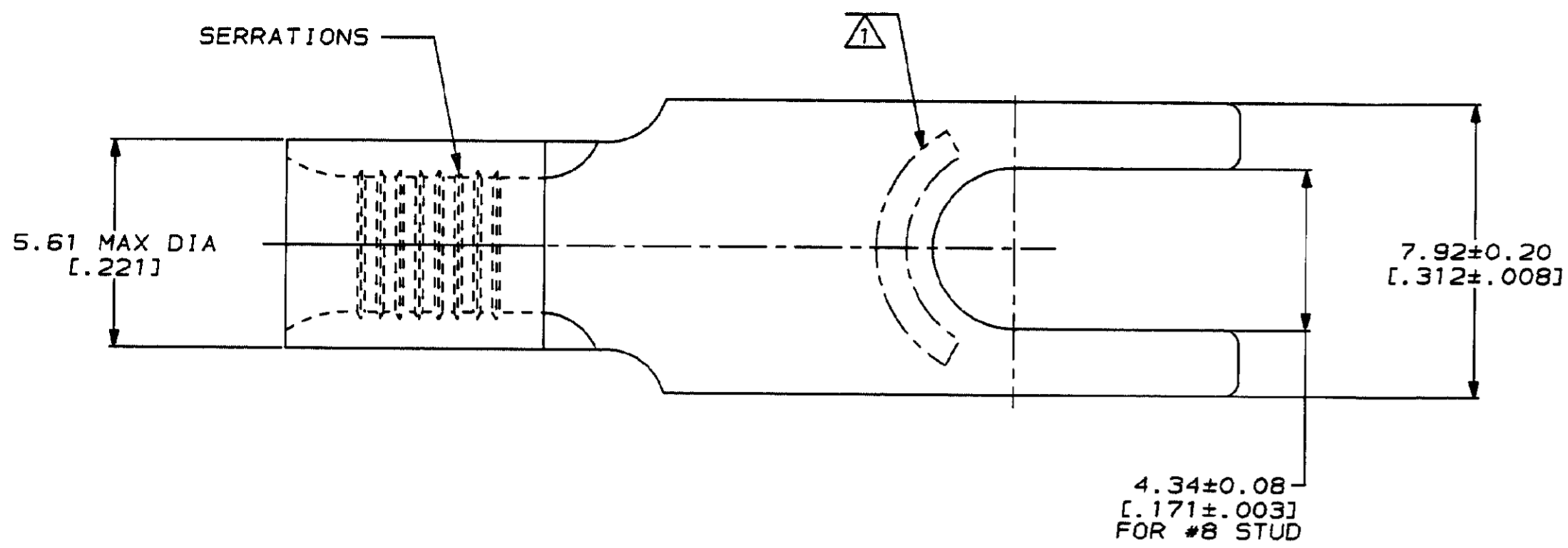

325195

| AMP INCORPORATED CUSTOMER SERVICE SYSTEMS | | MAX RECOMMENDED OPERATING TEMPERATURE: 170°C MAX | DO NOT SCALE PRINT. UNLESS SPECIFIED DIMENSIONS IN mm [INCHES] TOLERANCES ON: 2 PLC DEC ± - 3 PLC DEC ± - ANGLES ± - | DR 2-18-93 TA BRINKMAN | AMP Incorporated Harrisburg, PA 17105-3608 | |
|---|--|--|--|-----------------------------|---|--------------------|
| FOR ADDITIONAL PRODUCT INFORMATION OR COPIES OF DRAWINGS AND TECHNICAL DOCUMENTS | PRODUCT INFORMATION CENTER 1-800-522-6752 | VOLTAGE RATING: NOT APPLICABLE | MATERIAL COPPER PER ASTM B-152 ANNEALED | CHK 2-18-93 DA PATTERSON | NAME TERMINAL, SPADE TONGUE, BUDGET | |
| FOR APPLICATION TOOLING INFORMATION | TOOLING ASSISTANCE CENTER 1-800-722-1111 | WIRE CROSS SECTIONAL AREA RANGE: 2.62-6.64mm² [5,180-13,100] CIR MILS STRANDED | FINISH TIN PLATE 0.00254[.000100] MIN THK PER MIL-T-10727 | APPD 2-18-93 DE MILLER | SIZE C | CAGE CODE 00779 |
| FOR ORDER ENTRY | 1-800-526-5142 | THIS DRAWING IS A CONTROLLED DOCUMENT FOR AMP INCORPORATED. IT IS SUBJECT TO CHANGE AND THE CONTROLLING ENGINEERING ORGANIZATION SHOULD BE CONTACTED FOR THE LATEST REVISION. | | APPD 2-18-93 JL MECKLEY | DRAWING NO C-325195 | SCALE 8:1 |
| | | | | PRODUCT SPEC - | WEIGHT - | SHEET 1 OF 1 |