

TOSHIBA Bi-CMOS INTEGRATED CIRCUIT SILICON MOLITHIC**TB62754AFNG**

Step Up Type DC/DC Controller built in 6 ch sink driver for White LED

TB62754AFNG is a high efficient step-up type DC/DC controller specially designed for constant current drive of white LED.

This IC can drive white LEDs with constant current by dividing white LEDs, which are serial connected with lots of LEDs, into 6 lines.

LED current (I_F) is set with an external resistor and dimming control is available by PWM signal.

This IC is especially for driving back light white LEDs in large LCD which is 5 inches or more.

This IC is Pb-free product.

This IC is not in conformity with TS16949.

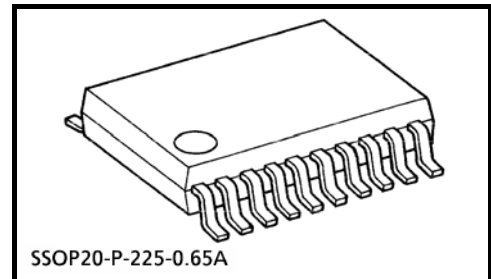

Weight :0.10g(TYP)

Characteristics

- Variable LED current (I_F) is set with an external resistor.
48mA (Typ.) @RSET =5.1 Ω
- IC package : SSOP20-P-225-0.65B
- Switching frequency : 1.6 MHz (Typ.)
- Constant current driver : Built-in open detect circuit.
- Built-in thermal shutdown circuit : 150 (MIN)
- Built-in output over voltage protect circuit : 32V(MIN)
-

Block Diagram

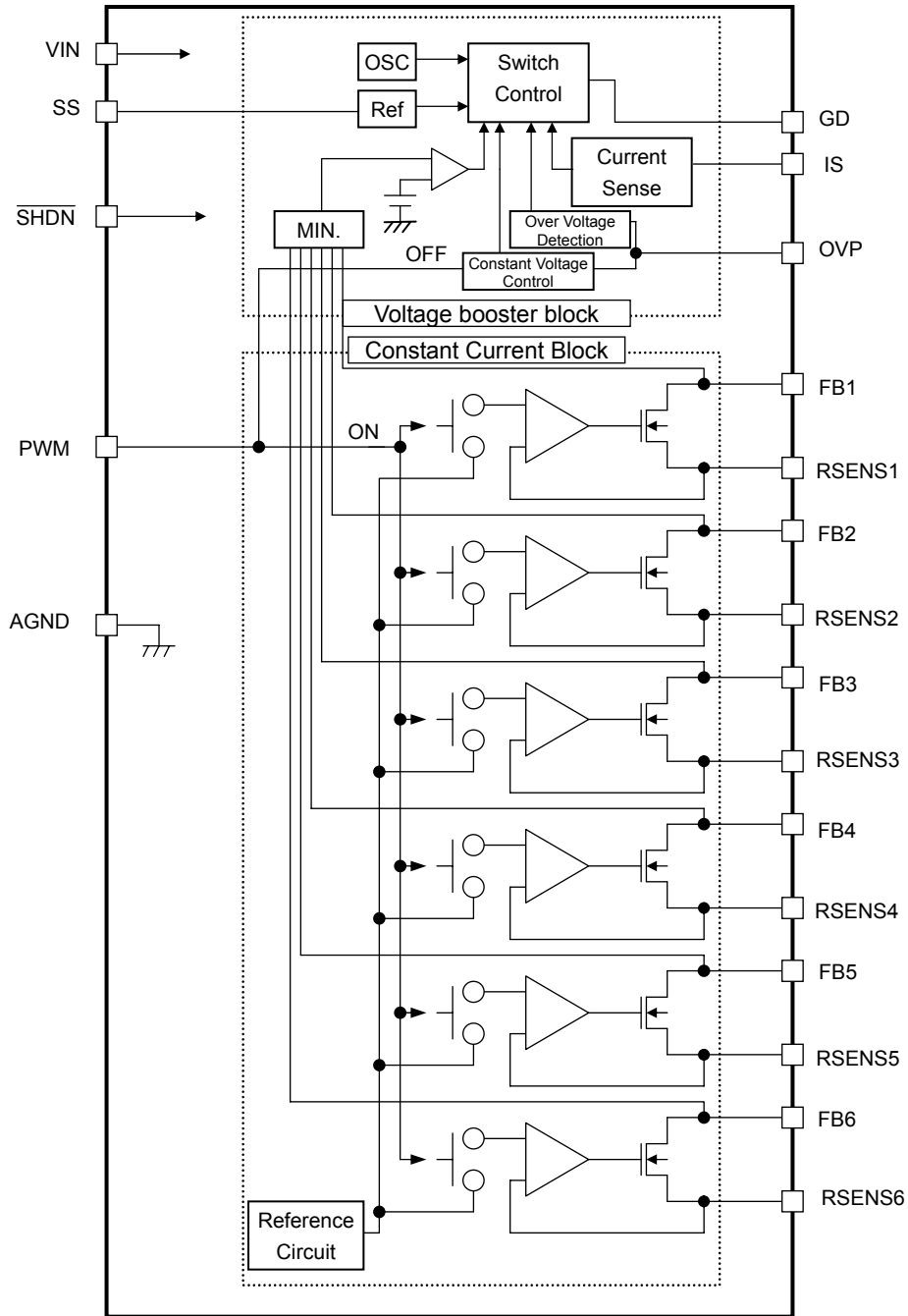

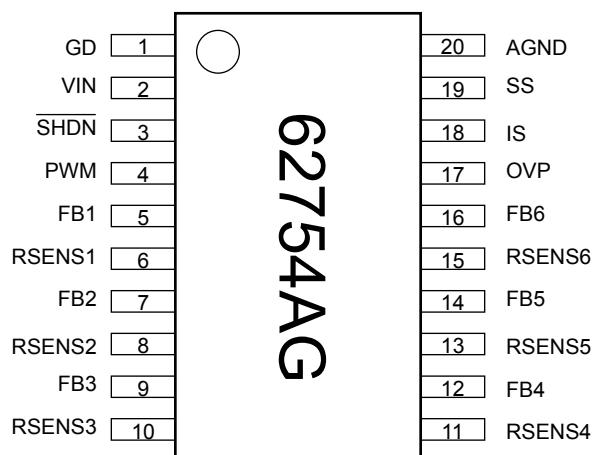
Pin Assignment (top view)

Note: This IC could be destroyed in some case if mounted in 180° inverse direction.
Please be careful about IC direction in mounting.

Pin Function

Pin No.	Symbol	Function Description																
1	GD	MOSFET control pin for DC/DC converter.																
2	VIN	Supply input pin for IC drive. Operating voltage: 4.5 to 5.5V.																
3	$\overline{\text{SHDN}}$	Input IC enable signal. $\overline{\text{SHDN}}=\text{"H"}$: Normal mode. $\overline{\text{SHDN}}=\text{"L"}$: Power saving mode. IC stops.																
4	PWM	Input ON/OFF control signal of constant current output pin (FB1 to 6). LED current (I_F) can be controlled by inputting PWM signal.																
		<table border="1"> <thead> <tr> <th>$\overline{\text{SHDN}}$ pin</th> <th>PWM pin</th> <th>Voltage booster block</th> <th>Constant current block</th> </tr> </thead> <tbody> <tr> <td>L</td> <td>-</td> <td>Stop</td> <td>Stop</td> </tr> <tr> <td>H</td> <td>H</td> <td>Feedback RSENS voltage</td> <td>Drive</td> </tr> <tr> <td>H</td> <td>L</td> <td>Feedback OVP voltage</td> <td>Stop</td> </tr> </tbody> </table>	$\overline{\text{SHDN}}$ pin	PWM pin	Voltage booster block	Constant current block	L	-	Stop	Stop	H	H	Feedback RSENS voltage	Drive	H	L	Feedback OVP voltage	Stop
		$\overline{\text{SHDN}}$ pin	PWM pin	Voltage booster block	Constant current block													
		L	-	Stop	Stop													
H	H	Feedback RSENS voltage	Drive															
H	L	Feedback OVP voltage	Stop															
5	FB1	Constant current synchronization.																
6	RSENS1	Constant current set resistor for sync driver (FB1).																
7	FB2	Constant current synchronization.																
8	RSENS2	Constant current set resistor for sync driver (FB2).																
9	FB3	Constant current synchronization.																
10	RSENS3	Constant current set resistor for sync driver (FB3).																
11	RSENS4	Constant current set resistor for sync driver (FB4).																
12	FB4	Constant current synchronization.																
13	RSENS5	Constant current set resistor for sync driver (FB5).																
14	FB5	Constant current synchronization.																
15	RSENS6	Constant current set resistor for sync driver (FB6).																
16	FB6	Constant current synchronization.																
17	OVP	Over voltage detection. IC switching operation is disabled with detection over voltage. When the voltage returns to detection level or less, operation is enabled again. In case $\overline{\text{SHDN}}$ is input H and PWM is input L, output voltage is kept over 20V (typ) by monitoring OVP voltage.																
18	IS	Monitoring MOSFET current.																
19	SS	When $\overline{\text{SHDN}}$ is input low to high, the constant number to limit the current is determined. VO _{UT} rising time changes depending on the constant number of Capacitor.																
20	AGND	Ground pin for analog.																

Application Circuit (Case of 3ch Outputs)

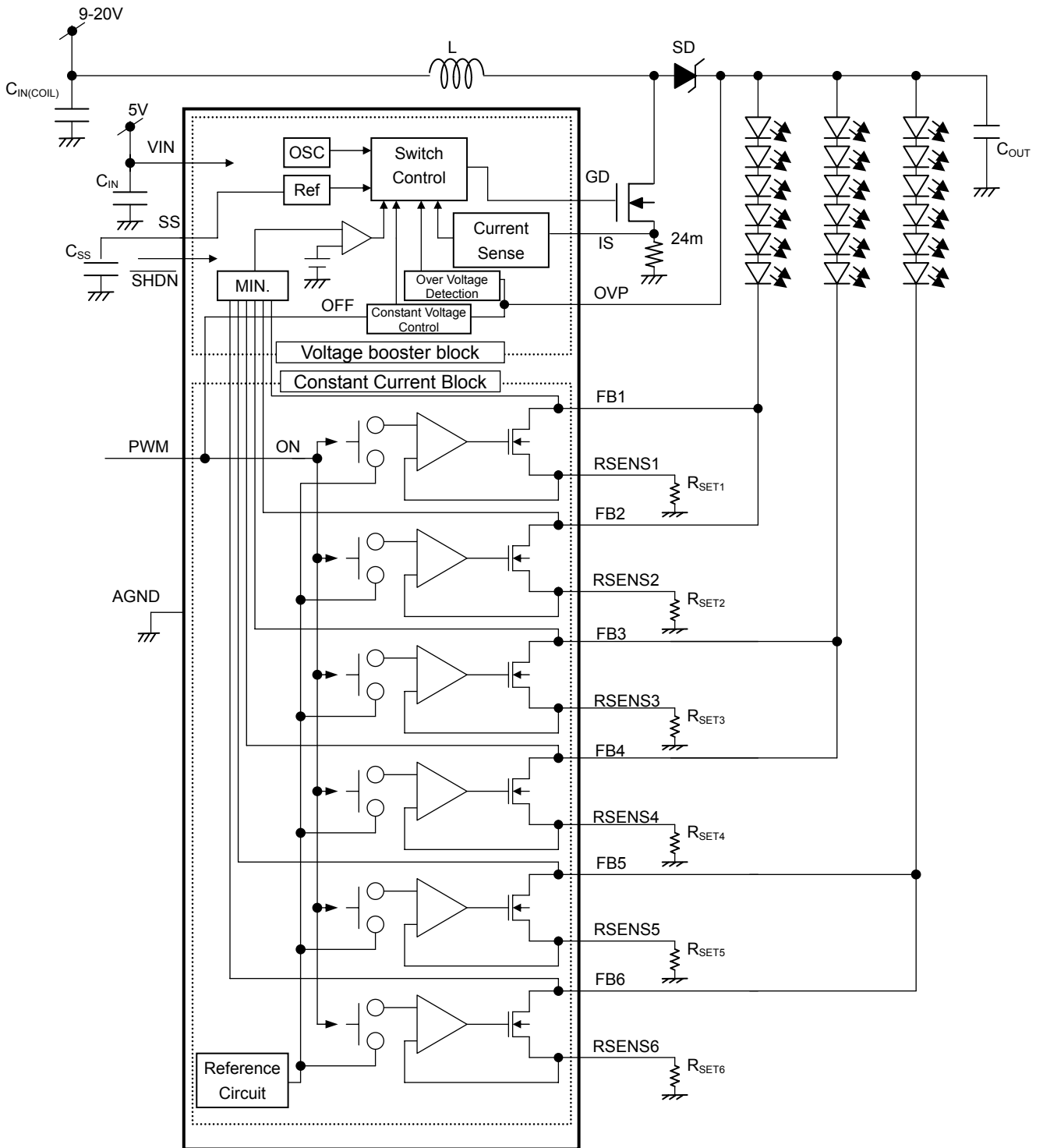

Application Circuit (Case of 6ch Outputs)

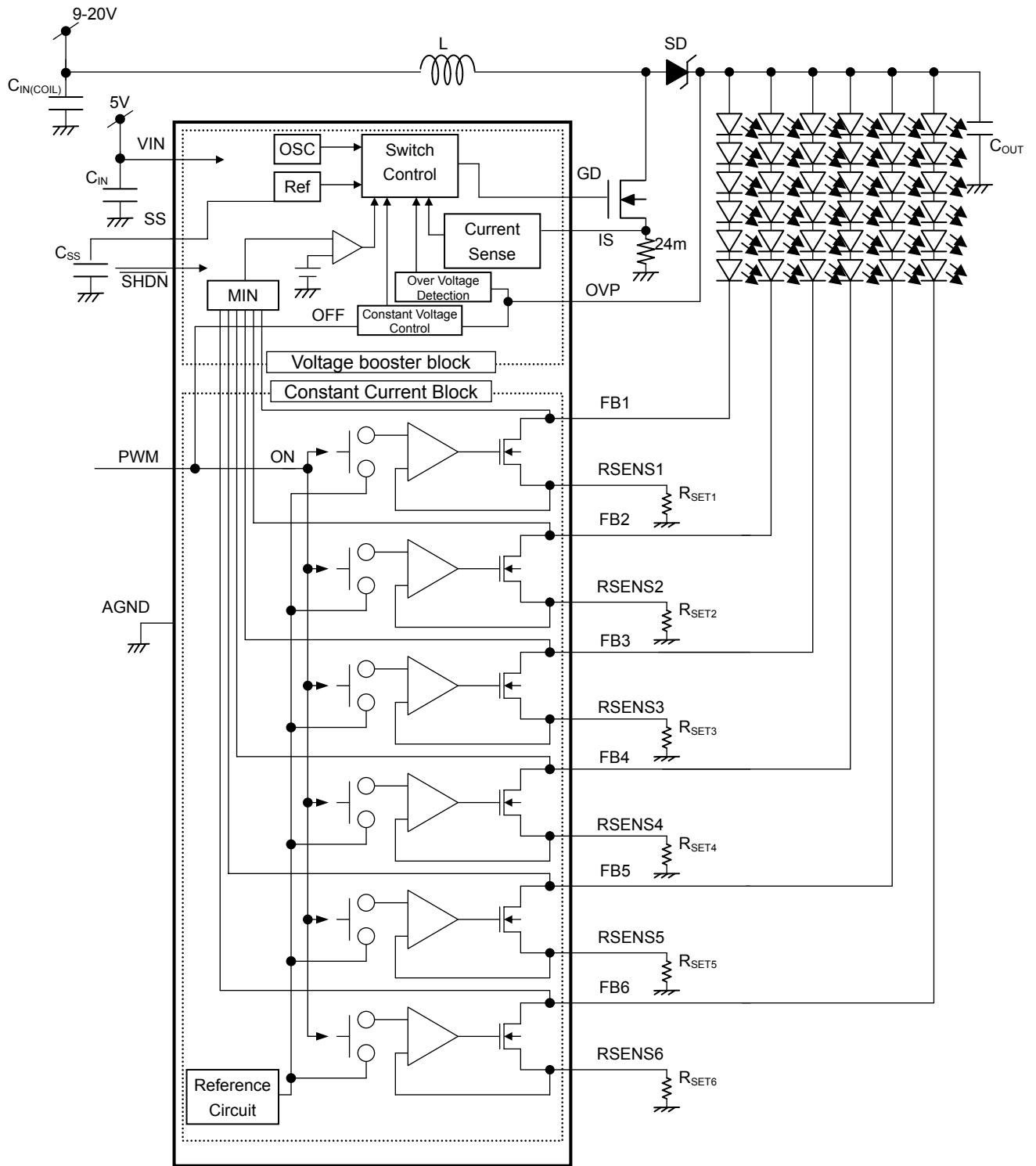

Explanation of Operation

Modes sets below are selectable by 2 input signals.

Mode	SHDN pin	PWM pin	Voltage booster block	Constant current block
Shutdown mode	L	-	Stop	Stop
LED drive mode	H	H	Feedback FB voltage	Drive
Constant current drive standby mode	H	L	Feedback OVP voltage	Stop

【Signal input sequence】

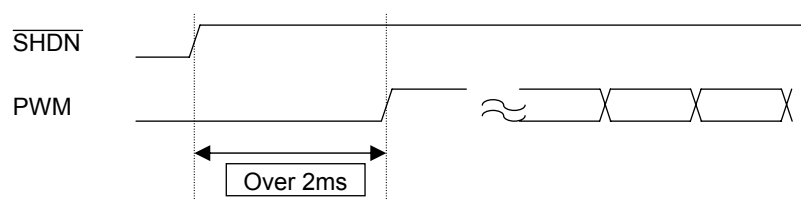

This IC has soft-start function to prevent rush current.

SHDN should be input high before PWM signal is input high because soft-start function works when PWM signal is input low.

Time difference between two input signals is recommended to be set 2 ms or more.

1 . Shutdown mode

It stops the operation.

Total consumption current is 1 μ A or less.

2 . LED drive mode

Voltage booster block and constant current block are both drive mode. Voltage booster block controls its voltage by monitoring FB voltage.

2-1 . Constant current control and voltage booster operation

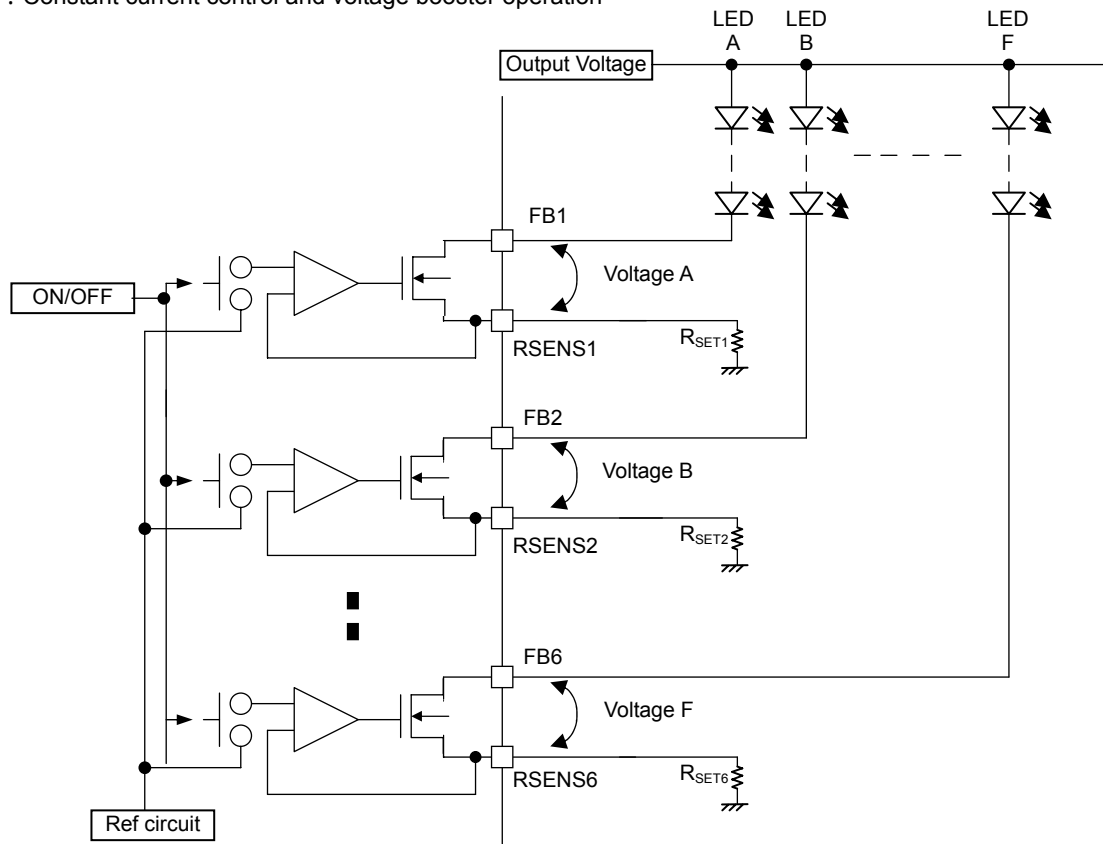

Applied voltage to FB1 to FB6 changes depending on Vf variation of white LED.
 The lowest voltage among "voltage A + V_{RSENS1} ", "voltage B + V_{RSENS2} " · · · , and "voltage F + V_{RSENS6} " in figure1 is determined as a reference value. And VOUT is controlled to set this reference voltage 1.25(Typ.).

(Ex.)

- LED A: TOTAL Vf = 25V
- LED B: TOTAL Vf = 24.5V
- LED F: TOTAL Vf = 25.5V

Output voltage is determined by referring "voltage F + V_{RSENS6} ".
 Output voltage = 25.5V + 1.25V = 26.75V
 In this case, voltage A is 1.5V, voltage B is 2V, and voltage F is 1V.

Applied voltage to each channel (FB1 to 6) changes depending on Vf variation of connected LED.
 However, in case power consumption exceeds power dissipation, IC is destroyed. Take care in designing by noticing the cautions below.

When applied voltage difference to FB pin is large, take care in determining current quantity per 1ch.
 The power dissipation is 1.5W in condition of 25 °C .
 $1.5W - (\text{Applied voltage per channel} \times \text{Set current} + \text{IC applied voltage} \times \text{IC consumption current}) > 0$
 (*) Whenever IC ambient temperature exceeds 25 °C , 12.5mW should be lopped off from 1.5W shown above.

(Ex.) In case ambient temperature is 60 °C ,
 $(1.5W - 12.5mW \times 60) - (\text{Applied voltage per channel} \times \text{Set current} + \text{IC applied voltage} \times \text{IC consumption current}) > 0$

3 . Constant current drive standby mode

Constant current block stops operating. Only voltage booster block drives.
Voltage booster block keeps its voltage 20V (Typ.) by monitoring OVP.

【Explanation of PWM dimmer control】

LED luminance is adjusted by switching LED drive mode and constant current drive standby mode. PWM signal is input to PWM pin and switches these 2 modes.

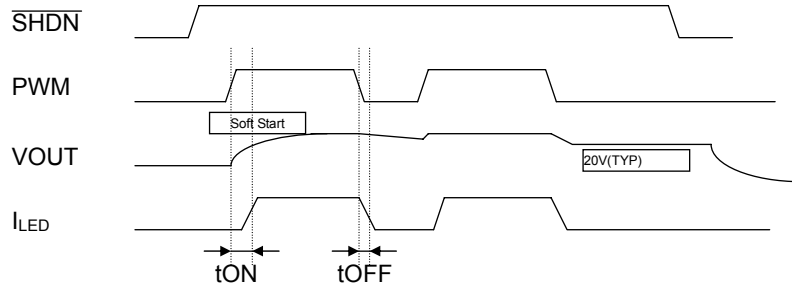

Voltage booster block starts driving by inputting high to $\overline{\text{SHDN}}$ pin.
VOUT starts rising at the set time with soft-start function.
LED current is not generated because PWM pin is input low and VOUT is controlled to 20V(Typ.).

LED current generates because $\overline{\text{SHDN}}$ is input high and PWM is input high.
VOUT is controlled by FB voltage.
Circuit delay is generated when LED current starts after PWM is input high.
This time is defined as tON in specification table.

Time passed since PWM is input low, and VOUT decreases with discharging.
However, VOUT keeps 20V (Typ.) because $\overline{\text{SHDN}}$ is input high.

$\overline{\text{SHDN}}$ is input low and the IC moves to shutdown mode.

Notice:

- When $\overline{\text{SHDN}}$ pin and PWM pin are turned on at the same time, VOUT has not had prepared voltage because of the soft-start function. So, ILED is different from the set current until VOUT has enough voltage.

4 . Set time range of PWM ON/OFF

Cycle set of PWM signal is 1 to 10 kHz.

However, take care in setting PWM cycle because the minimum ON/OFF time is defined as 10 μ s.

Ex.) When PWM signal frequency is set 10kHz, duty width has 0, 10 to 90, and 100%.

When PWM signal frequency is set 1 kHz, duty width has 0, 1 to 99, and 100%.

5 . Soft-start function

Soft-start function is built in this IC.

However, this function is available when $\overline{\text{SHDN}}$ pin is input from low to high.

It does not work while PWM signal changes.

Soft-start setting time can be adjusted with external capacitor C_{SS} .

6 . Thermal shut down function

When IC temperature reaches specified temperature and TSD circuit drives, output is turned off by driving internal shutdown circuit. TSD operation temperature range is 150 to 180 .

7 . LED open protection

The protection function shown below works when LED is open during operation.

1) V_{OUT} rises and OVP function works.

2) V_{OUT} rises and thermal shutdown function works influenced by internal power consumption before it reaches OVP voltage.

Applied voltage status of FB pins (1to 6) is detected when the protection function shown above works.

Outputs of these pins stop when open status pin exists.

$\overline{\text{SHDN}}$ pin should be input again to release the stop mode.

(In case LED is open during normal operation.)

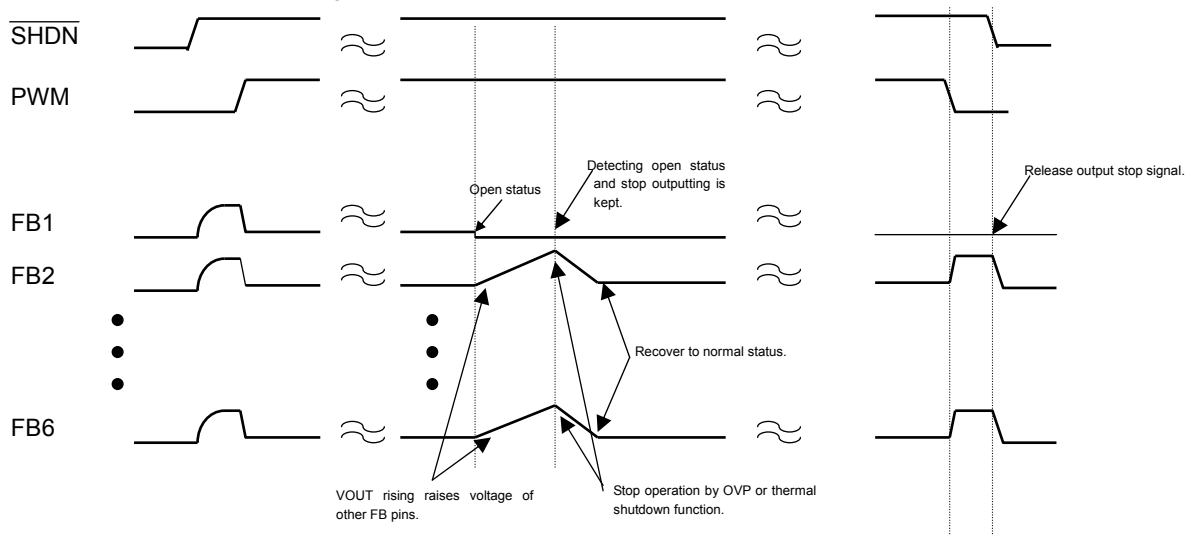

8 . Handling of unused channels

In case unused channels are used at open status, unnecessary consumption current may generate and the handling shown below is needed.

- RSENS pin of unused channels should be connected VIN.

Ex.) In case Ch6 is unused.

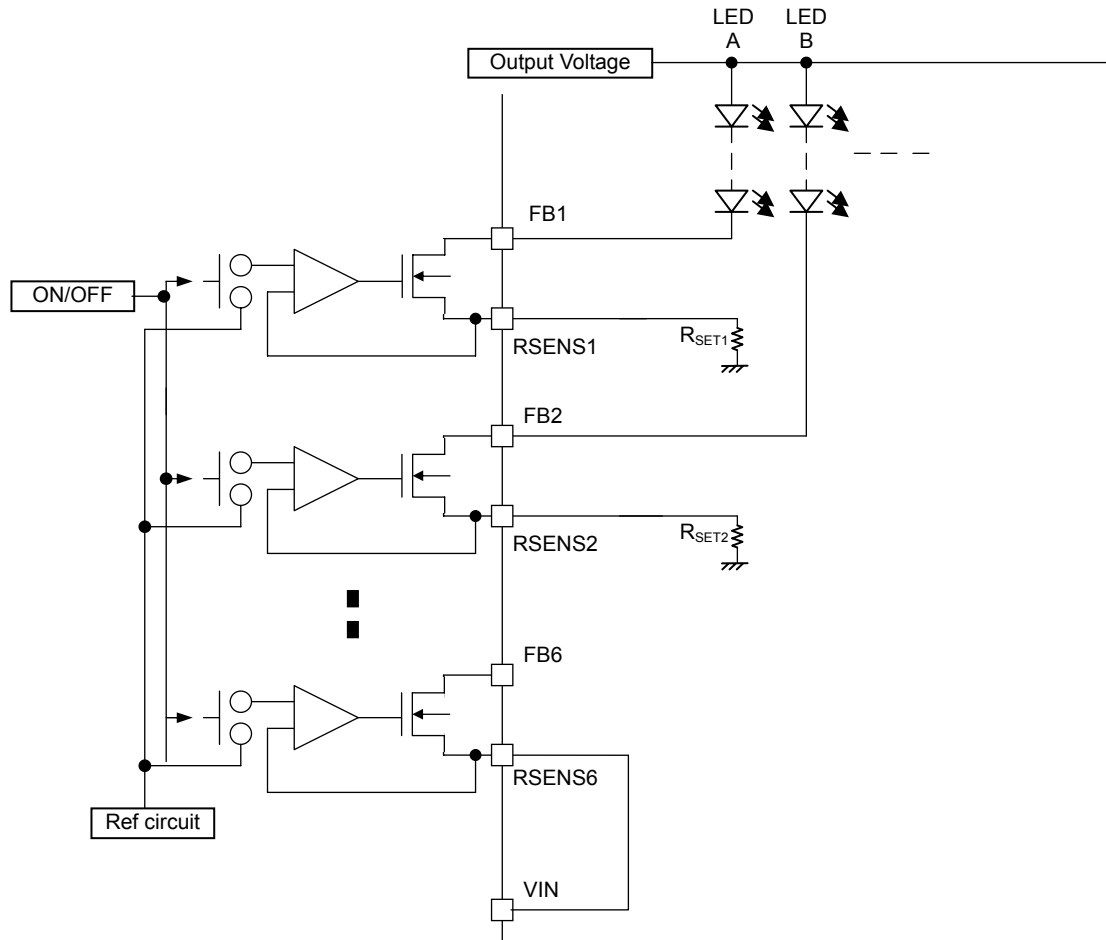

Absolute Maximum Ratings (Ta = 25°C if without notice)

Characteristics	Symbol	Rating	Unit
Power supply voltage	V _{IN}	-0.3 ~ +6	V
Power supply voltage (Coil)	V _{IN(Coil)}	9 ~ 24	V
Input voltage	V _{IN(LOGIC)}	-0.3 ~ +VIN+0.3V	V
FB terminal input voltage	V _{IN(FB)}	-0.3 ~ 40	V
LED Setting Current (each Channel)	I _F (MAX)	80	mA
Power dissipation	P _D	0.8 (Device)	W
		1.5 (ON PCB) Note1	
Thermal resistance	R _{th(j-a)}	150 (Device)	°C/W
		120 (ON PCB)	
Operation temperature range	T _{opr}	-40~+95	°C
Storage temperature range	T _{stg}	-55~+150	°C
Maximum junction temperature	T _j	150	°C

Note1: Power dissipation must be calculated with subtraction of 12.5 mW/°C from maximum rating with every 1°C if T_{opr} is upper 25°C. (on PCB)

Recommended Operating Condition (Ta = -40 to 95°C if without notice)

Characteristics	Symbol	Condition	Min	Typ.	Max	Unit
Power supply voltage	V _{IN}		4.5	-	5.5	V
Power supply voltage (Coil)	V _{IN(Coil)}		9	-	20	V
PWM terminal Input signal frequency	f _{PWM}		0.1	-	10	kHz
LED setting current range	I _{F(RANGE)}	FB1,FB2,FB3,FB4,FB5,FB6	30	-	70	mA
LED setting current	I _F	V _{IN} =5V, R _{SENS} =5.1Ω 18LEDs, Ta=25	-	48	-	mA
PWM signal Input pulse width			10	-	-	μs
Input capacitance for Coil	CIN(COIL)		-	22	-	μF
Input Capacitance	CIN		-	1	-	μF
Output Capacitance	COUT		-	10	-	μF
Capacitance for soft start	C _{SS}		-	0.047	-	μF
Inductance	L		-	2.4	-	μH
Resistance for ISENS	R1		-	24	-	mΩ

Electrical Characteristics (Ta = 25°C, VIN = 4.5 to 5.5 V if without notice)

Characteristics	Symbol	Test Condition	Min	Typ.	Max	Unit
Operating consumption current	I _{IN} (On)	SHDN = H , PWM = H , R _{SENS1~6} = 5.1	-	7.5	15	mA
		SHDN = H , PWM = H , R _{SENS1~6} = 5.1 , V _{OVP} = 40V	-	2	3	mA
Operating consumption current	I _{IN} (Off)	VIN=5.0V,SHDN=L	-	0.5	1.0	μA
Input terminal "H" level voltage	V _{(LOGIC)H}		1.5	-	VIN	V
Input terminal "L" level voltage	V _{(LOGIC)L}	-	0	-	0.4	V
Input terminal Current	I _{LOGIC}	V _{LOGIC} =5.0V	-	0	1.0	μA
Switching frequency	f _{OSC}		1.23	1.60	2.28	MHz
GD terminal leakage current	I _{oz} (GD)	VIN=5.0V,SHDN=L	-	0.5	1	μA
OVP terminal detect voltage	V _{OVP}		32	35.5	39	V
OVP terminal input current	I _{OVP}	SHDN = H , PWM = H , V _{OVP} =29V Input	-	100	200	μA
OVP terminal leakage current	I _{OVP} PLK	SHDN = L	-	0.5	1	μA
SS terminal output current	I _{SS}	SHDN="L"→"H"	20	-	60	μA
Soft start setting time		C _{SS} = 0.047μF	-	1	2	ms
Thermal shutdown temperature (detect temperature)	T _{TSD}		150	-	190	
RSENS terminal feedback voltage	RSENS _{1~6}	SHDN = H , PWM = H	0.235	0.245	0.255	V
Constant Current regulation			-	-	4	%
FB terminal leakage current	I _{FBLEAK1~6}	SHDN = H , PWM = L	-	-	1	μA
Output current ON time	t _{ON}		-	-	0.3	μs
Output current OFF time	t _{OFF}		-	-	0.15	μs

Package Dimensions

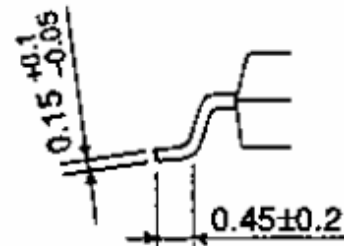
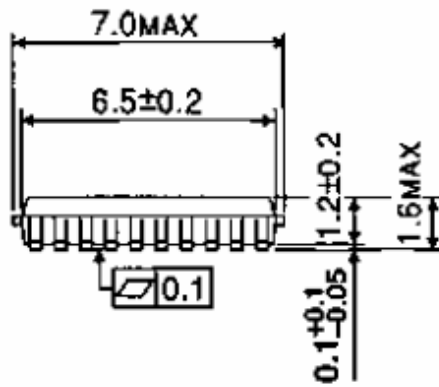
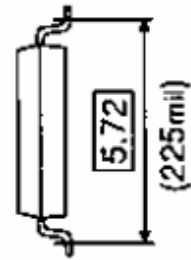
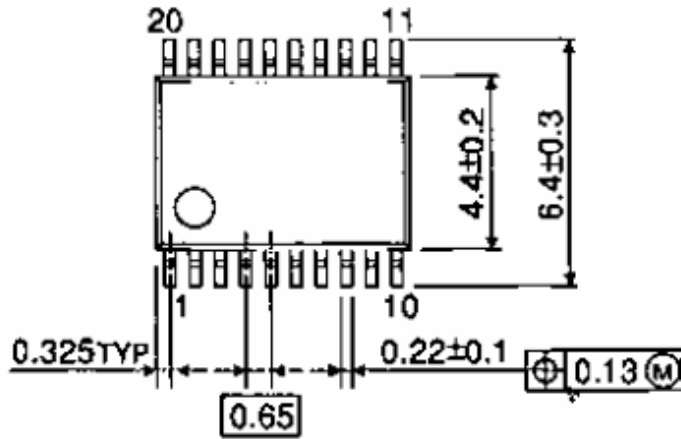

Weight: 0.10g (TYP)

Notes on Contents**1. Block Diagrams**

Some of the functional blocks, circuits, or constants in the block diagram may be omitted or simplified for explanatory purposes.

2. Equivalent Circuits

The equivalent circuit diagrams may be simplified or some parts of them may be omitted for explanatory purposes.

3. Timing Charts

Timing charts may be simplified for explanatory purposes.

4. Application Circuits

The application circuits shown in this document are provided for reference purposes only. Thorough evaluation is required, especially at the mass production design stage.

Toshiba does not grant any license to any industrial property rights by providing these examples of application circuits.

5. Test Circuits

Components in the test circuits are used only to obtain and confirm the device characteristics. These components and circuits are not guaranteed to prevent malfunction or failure from occurring in the application equipment.

IC Usage Considerations**Notes on handling of ICs**

- [1] The absolute maximum ratings of a semiconductor device are a set of ratings that must not be exceeded, even for a moment. Do not exceed any of these ratings.
Exceeding the rating(s) may cause the device breakdown, damage or deterioration, and may result injury by explosion or combustion.
- [2] Use an appropriate power supply fuse to ensure that a large current does not continuously flow in case of over current and/or IC failure. The IC will fully break down when used under conditions that exceed its absolute maximum ratings, when the wiring is routed improperly or when an abnormal pulse noise occurs from the wiring or load, causing a large current to continuously flow and the breakdown can lead smoke or ignition. To minimize the effects of the flow of a large current in case of breakdown, appropriate settings, such as fuse capacity, fusing time and insertion circuit location, are required.
- [3] If your design includes an inductive load such as a motor coil, incorporate a protection circuit into the design to prevent device malfunction or breakdown caused by the current resulting from the inrush current at power ON or the negative current resulting from the back electromotive force at power OFF. IC breakdown may cause injury, smoke or ignition.
Use a stable power supply with ICs with built-in protection functions. If the power supply is unstable, the protection function may not operate, causing IC breakdown. IC breakdown may cause injury, smoke or ignition.
- [4] Do not insert devices in the wrong orientation or incorrectly.
Make sure that the positive and negative terminals of power supplies are connected properly.
Otherwise, the current or power consumption may exceed the absolute maximum rating, and exceeding the rating(s) may cause the device breakdown, damage or deterioration, and may result injury by explosion or combustion.
In addition, do not use any device that is applied the current with inserting in the wrong orientation or incorrectly even just one time.
- [5] Carefully select external components (such as inputs and negative feedback capacitors) and load components (such as speakers), for example, power amp and regulator.
If there is a large amount of leakage current such as input or negative feedback condenser, the IC output DC voltage will increase. If this output voltage is connected to a speaker with low input withstand voltage, overcurrent or IC failure can cause smoke or ignition. (The over current can cause smoke or ignition from the IC itself.) In particular, please pay attention when using a Bridge Tied Load (BTL) connection type IC that inputs output DC voltage to a speaker directly.

About solderability, following conditions were confirmed

- Solderability

- (1) Use of Sn-63Pb solder Bath

- solder bath temperature = 230°C
 - dipping time = 5 seconds
 - the number of times = once
 - use of R-type flux

- (2) Use of Sn-3.0Ag-0.5Cu solder Bath

- solder bath temperature = 245°C
 - dipping time = 5 seconds
 - the number of times = once
 - use of R-type flux

RESTRICTIONS ON PRODUCT USE

030619EBA

- The information contained herein is subject to change without notice.
- The information contained herein is presented only as a guide for the applications of our products. No responsibility is assumed by TOSHIBA for any infringements of patents or other rights of the third parties which may result from its use. No license is granted by implication or otherwise under any patent or patent rights of TOSHIBA or others.
- TOSHIBA is continually working to improve the quality and reliability of its products. Nevertheless, semiconductor devices in general can malfunction or fail due to their inherent electrical sensitivity and vulnerability to physical stress. It is the responsibility of the buyer, when utilizing TOSHIBA products, to comply with the standards of safety in making a safe design for the entire system, and to avoid situations in which a malfunction or failure of such TOSHIBA products could cause loss of human life, bodily injury or damage to property.
In developing your designs, please ensure that TOSHIBA products are used within specified operating ranges as set forth in the most recent TOSHIBA products specifications. Also, please keep in mind the precautions and conditions set forth in the "Handling Guide for Semiconductor Devices," or "TOSHIBA Semiconductor Reliability Handbook" etc..
- The TOSHIBA products listed in this document are intended for usage in general electronics applications (computer, personal equipment, office equipment, measuring equipment, industrial robotics, domestic appliances, etc.). These TOSHIBA products are neither intended nor warranted for usage in equipment that requires extraordinarily high quality and/or reliability or a malfunction or failure of which may cause loss of human life or bodily injury ("Unintended Usage"). Unintended Usage include atomic energy control instruments, airplane or spaceship instruments, transportation instruments, traffic signal instruments, combustion control instruments, medical instruments, all types of safety devices, etc.. Unintended Usage of TOSHIBA products listed in this document shall be made at the customer's own risk.
- The products described in this document are subject to the foreign exchange and foreign trade laws.
- TOSHIBA products should not be embedded to the downstream products which are prohibited to be produced and sold, under any law and regulations.