

Apr.1.2017 Copyright 2017 HIROSE ELECTRIC CO., LTD. All Rights Reserved.

COUNT	DESCRIPTION OF REVISIONS	BY	CHKD	DATE	COUNT	DESCRIPTION OF REVISIONS	BY	CHKD	DATE
△				..	△				..
△				..	△				..
△				..	△				..

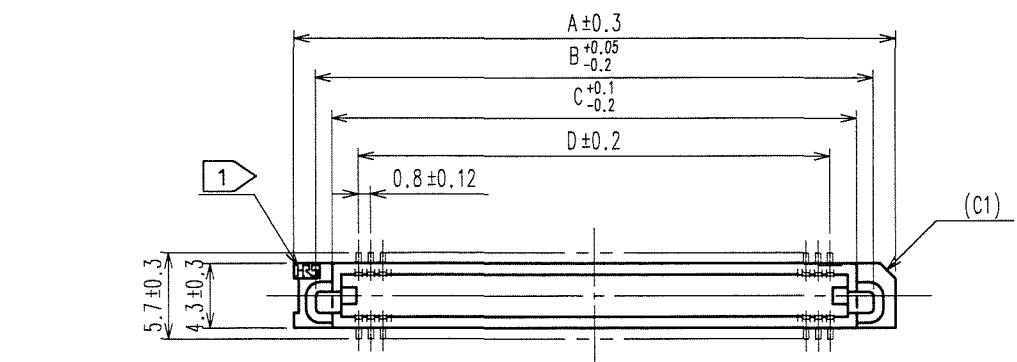

A-A(10:1)

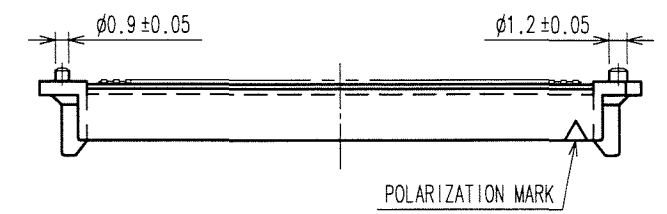
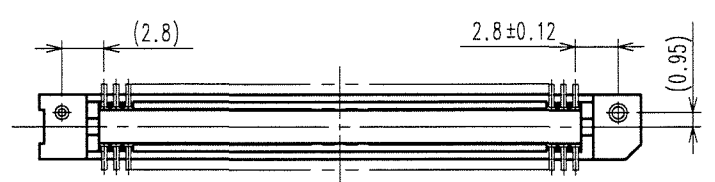
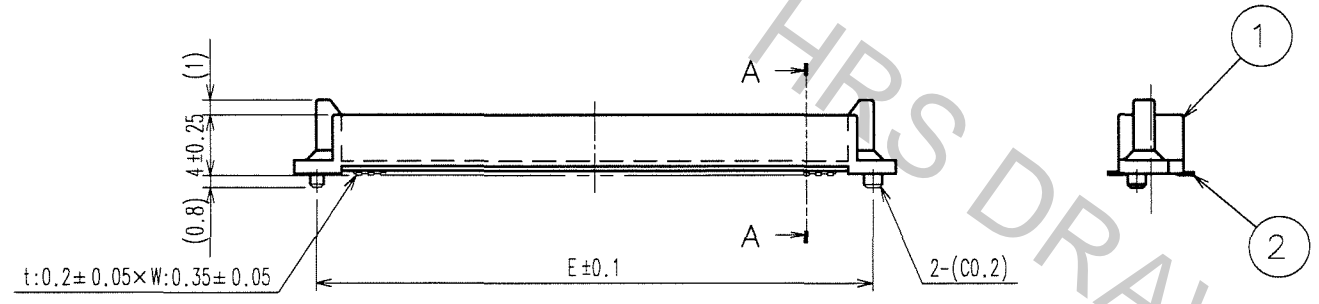
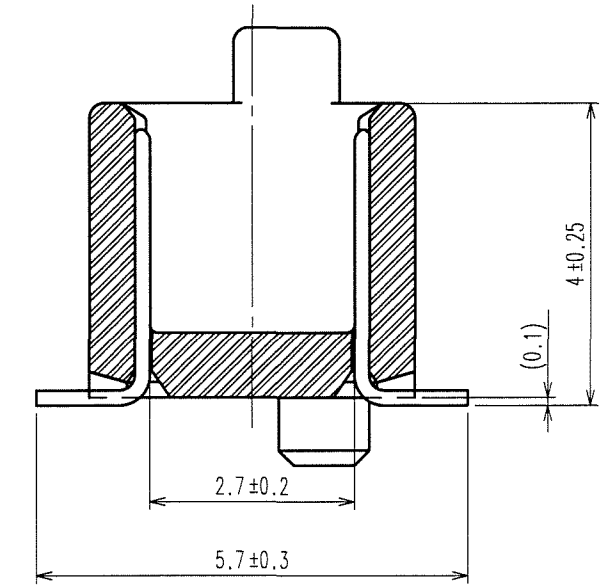

PART No.	CODE No.	5	A	B	C	D	E
FX6-20P-0.8SV(71)	CL576-0001-3-71	20	15.8	12.9	10.7	7.2	12.8
FX6-40P-0.8SV(71)	CL576-0003-9-71	40	23.8	20.9	18.7	15.2	20.8
FX6-50P-0.8SV(71)	CL576-0004-1-71	50	27.8	24.9	22.7	19.2	24.8
FX6-60P-0.8SV(71)	CL576-0005-4-71	60	31.8	28.9	26.7	23.2	28.8
FX6-80P-0.8SV(71)	CL576-0007-0-71	80	39.8	36.9	34.7	31.2	36.8
FX6-100P-0.8SV(71)	CL576-0008-2-71	100	47.8	44.9	42.7	39.2	44.8

- NOTE
- 1 HRS MARK SHALL BE OPTIONAL.
 - 2 LEAD CO-PLANARITY SHALL BE 0.1mm MAX.
 - 3 FOR MODIFICATION, ETC., PREVENTIVE HOLE FOR SINK MARK MAY BE ADDED ACCORDING TO CIRCUMSTANCES.
 - 4 THE DIMENSIONS IN PARENTHESES ARE FOR REFERENCE.
 - 5 NUMBER OF CONTACTS.

RECOMMENDED LAND PATTERN DIMENSION OF PCB (MOUNTING SIDE)

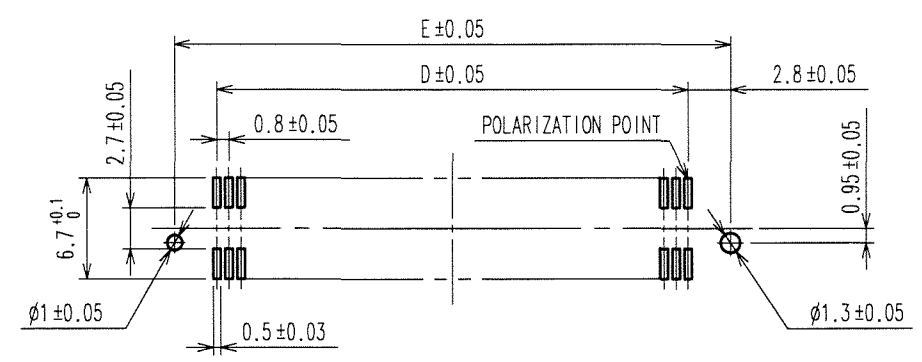

1	PPS	LIGHT BROWN (UL94V-0)	2	PHOSPHOR BRONZE	CONTACT AREA: GOLD 0.1μm min. LEAD AREA: GOLD FLASH UNDER PLATING: NICKEL 1μm min.	
NO.	MATERIAL	FINISH, REMARKS	NO.	MATERIAL	FINISH, REMARKS	
CODE NO. (OLD)		DRAWN	DESIGNED	CHECKED	APPROVED	RELEASED
		A. SUZUKAWA	H. Nakamura	X. Ogawa	H. Okawa	..
		06.05.23	06.05.24	06.05.24	06.05.24	..
DRAWING NO. EDC3-071174-25			PART NO. FX6-**P-0.8SV(71)			
SCALE FREE			CODE NO. CL576			
UNITS mm			1/1			

TO
PCK