

THIS DRAWING IS UNPUBLISHED. RELEASED FOR PUBLICATION ,19 .
 © COPYRIGHT 19 BY AMP INCORPORATED. ALL INTERNATIONAL RIGHTS RESERVED.

LOC	DIST	P	F	ZONE	LTR	DESCRIPTION	DATE	APPD
G	14					C REVISED PER 0L20-0220-97	020CT97	OK MJS

AMP WIRE RANGE	UL E13288 Listed
2 AWG SOLID OR STRANDED	2 AWG STRANDED
SP LR7189 Certified	MILITARY P/N AND CLASS
2 AWG SOLID OR STRANDED	NOT APPLICABLE

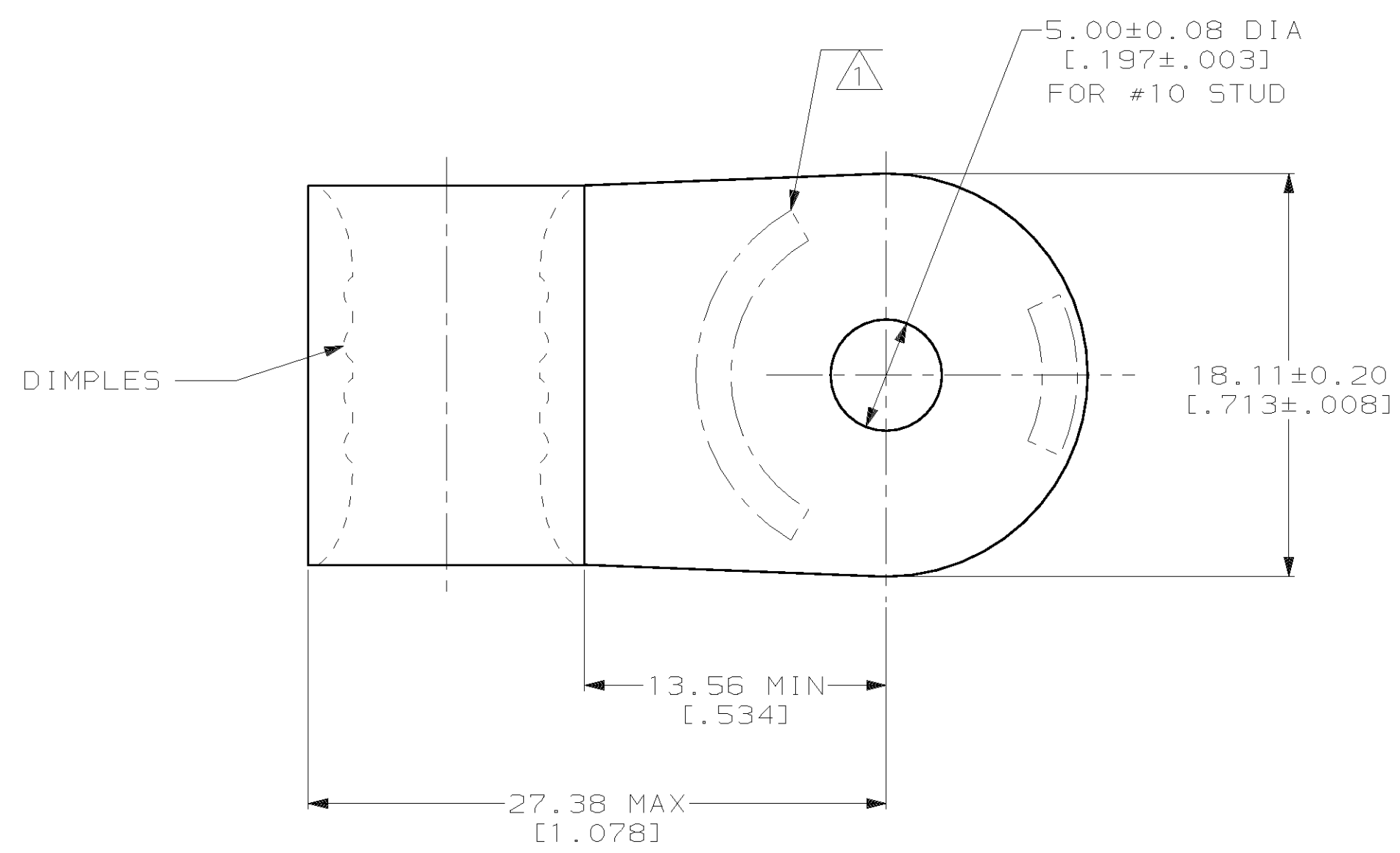

1 STAMP AMP 2W* 60-75 APPROX AS SHOWN

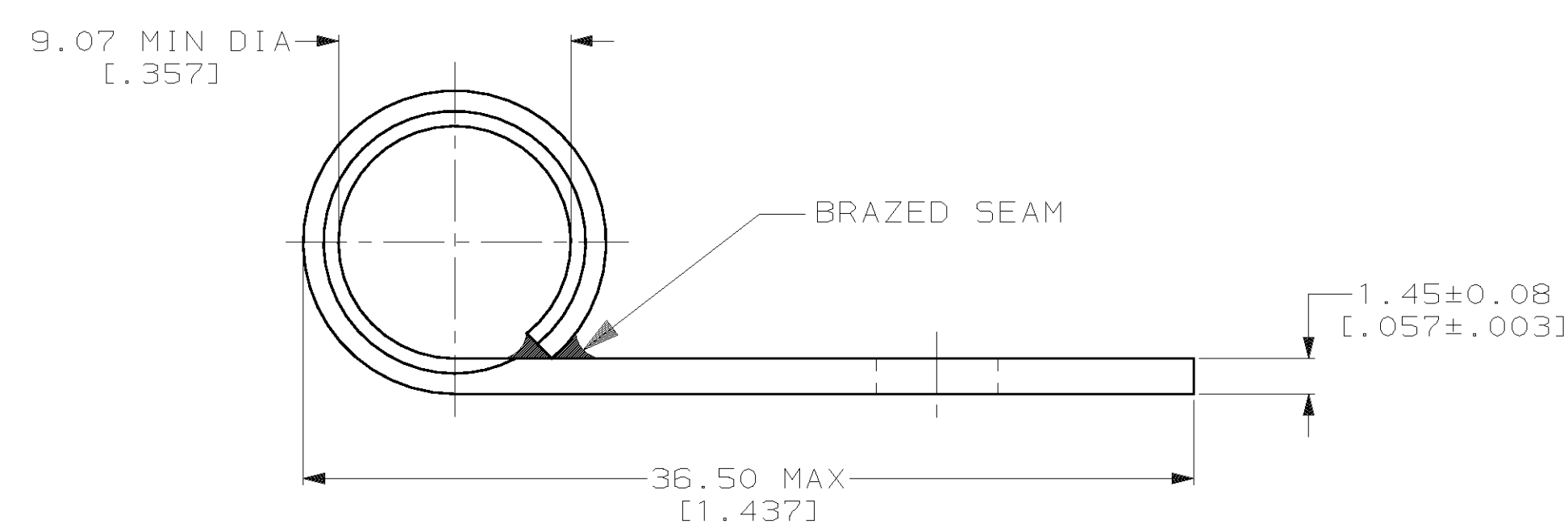

321063

321063
PART NO

AMP INCORPORATED
CUSTOMER SERVICE SYSTEMS

MAX RECOMMENDED OPERATING TEMPERATURE:
170°C MAX

DO NOT SCALE PRINT. UNLESS SPECIFIED
DIMENSIONS IN mm (INCHES)
TOLERANCES ON:
2 PLC DEC ± -
3 PLC DEC ± -
ANGLES ± -

DR 4-8-93
TA BRINKMAN
CHK 4-8-93
DA PATTERSON
APPD 4-8-93
DE MILLER
APPD 4-8-93
JL MECKLEY

AMP AMP Incorporated
Harrisburg, PA 17105-3608

FOR ADDITIONAL PRODUCT INFORMATION OR COPIES OF DRAWINGS AND TECHNICAL DOCUMENTS

PRODUCT INFORMATION CENTER
1-800-522-6752

VOLTAGE RATING:
NOT APPLICABLE

MATERIAL
COPPER PER ASTM B-152 ANNEALED

PRODUCT SPEC
-

NAME
TERMINAL, RING TONGUE, FLAG, SOLISTRAND™

FOR APPLICATION TOOLING INFORMATION

TOOLING ASSISTANCE CENTER
1-800-722-1111

WIRE CROSS SECTIONAL AREA RANGE:
26.7-42.4mm² [52,600-83,700] CIR MILS
SOLID OR STRANDED

FINISH
TIN PLATE
0.00254 [0.00100] MIN THK PER ASTM B-545

APPLICATION SPEC
-

SIZE CAGE CODE DRAWING NO
C 00779 C=321063

FOR ORDER ENTRY

1-800-526-5142

THIS DRAWING IS A CONTROLLED DOCUMENT FOR AMP INCORPORATED. IT IS SUBJECT TO CHANGE AND THE CONTROLLING ENGINEERING ORGANIZATION SHOULD BE CONTACTED FOR THE LATEST REVISION.

WEIGHT
-

SCALE 4:1

SHEET 1 OF 1