

THIS DRAWING IS UNPUBLISHED. RELEASED FOR PUBLICATION  
 © COPYRIGHT - By - ALL RIGHTS RESERVED.

LOC	DIST	REVISIONS					
AF	50	P	LTR	DESCRIPTION	DATE	DWN	APVD
		F		REVISED PER ECR-12-013459	29NOV2012	KH	PD

- 1 CONTINUOUS STRIP ON REELS
- 2 MATING TAB THK IS  $.032 \pm .001$
- 3 WIRE SIZE IS #18-#14 AWG
- 4 INSULATION RANGE IS  $.060-.110$  DIA.
- 5  PRELIMINARY - NOT FOR PRODUCTION

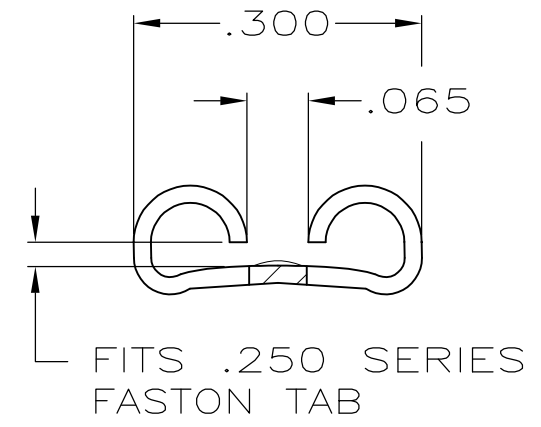
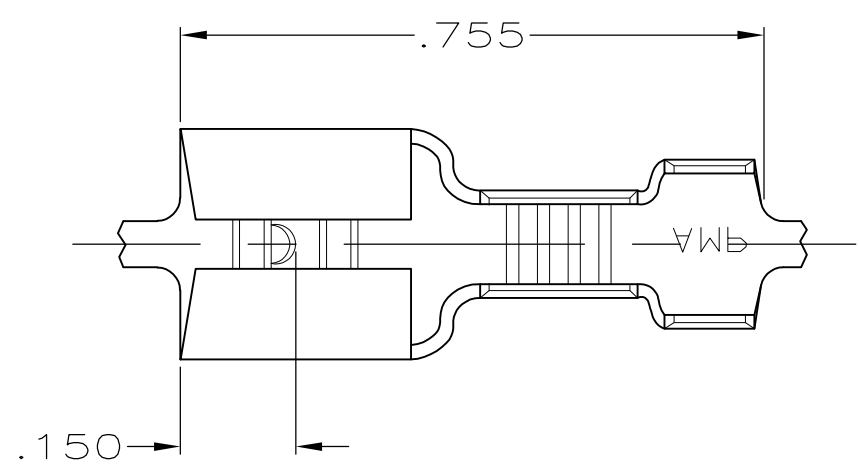

VIEW A-A  
SCALE 5:1

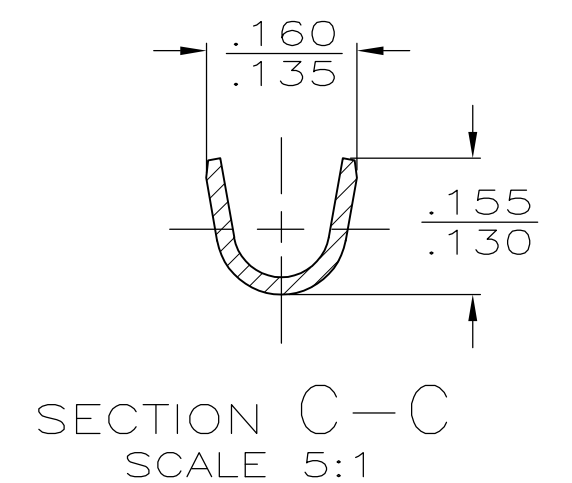
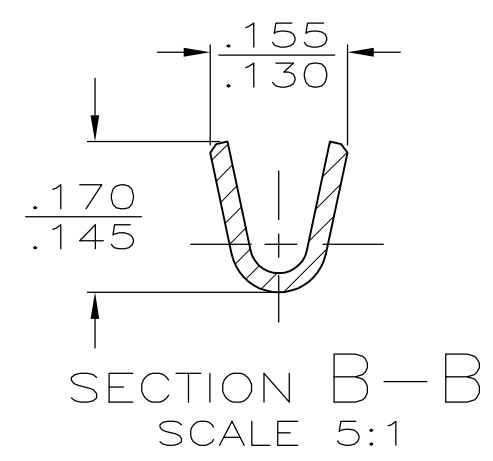
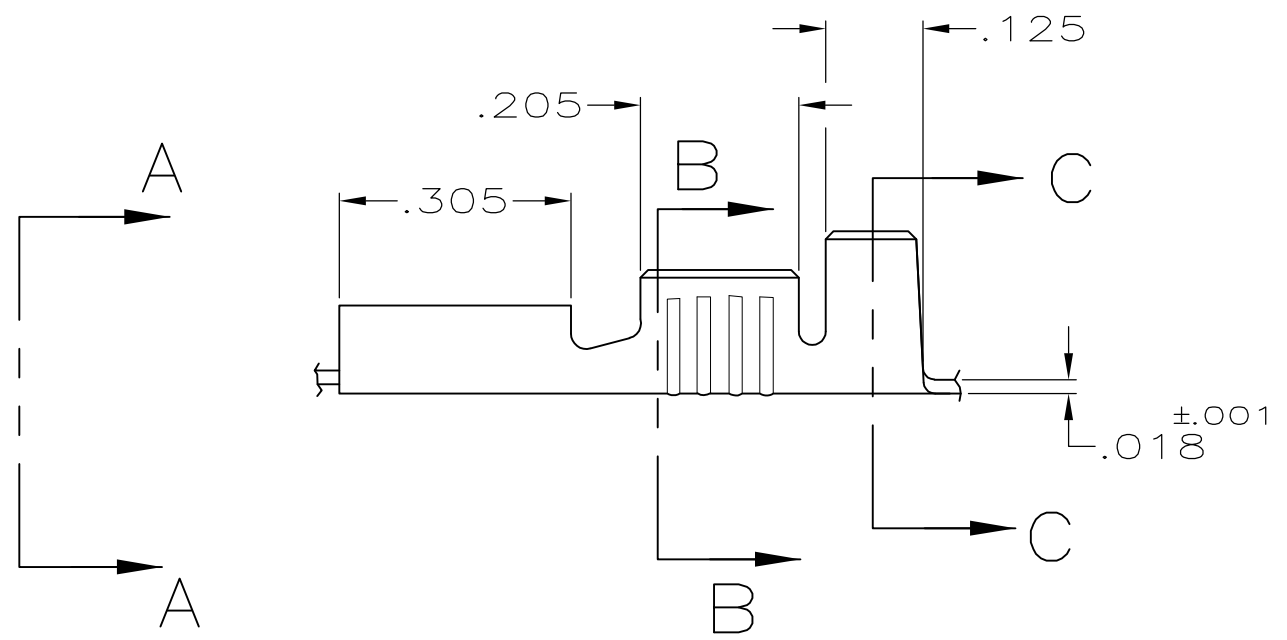

TIN	H03 PHOS BRONZE		61375-3
TIN	BRASS		61375-1
FINISH	MATERIAL		PART NO

F	.120	.252	F	.120	.075	14
					.066	16
					.061	18
TYPE	WIDTH	STRIP LENGTH	TYPE	WIDTH	±.002 HEIGHT	WIRE
INSUL BARREL CRIMP		±.015	WIRE BARREL CRIMP			

THIS DRAWING IS A CONTROLLED DOCUMENT.

DIMENSIONS: INCHES

TOLERANCES UNLESS OTHERWISE SPECIFIED:

0 PLC	± -
1 PLC	± -
2 PLC	± -
3 PLC	± .015
4 PLC	± -
ANGLES	± -

MATERIAL: SEE TABLE

FINISH: SEE TABLE

DWN JR RUTH 7/10/89

CHK MS FEHER 7/10/89

APVD C MEYERS 7/10/89

PRODUCT SPEC

APPLICATION SPEC

WEIGHT -

CUSTOMER DRAWING

**STE** TE Connectivity

RECEPTACLE, FASTON™  
.250 SERIES

SIZE	CAGE CODE	DRAWING NO	RESTRICTED TO
A3	00779	C-61375	-

SCALE 4:1 SHEET 1 OF 1 REV F