

Tool Specification

1. Part Number: YRS-1460

2. Terminal: SZE-002T-P0.3 / SZPD-002T-P0.3

3. Application

Crimp Position	AWG	Tensile Strength N (kgf)	Strip Length mm
28	UL1061 AWG 28	10(1.0)min.	2.1
26-24	UL1061 AWG 26	20(2.0)min.	2.1
26-24	UL1061 AWG 24	(30(3.1)min.)	2.1

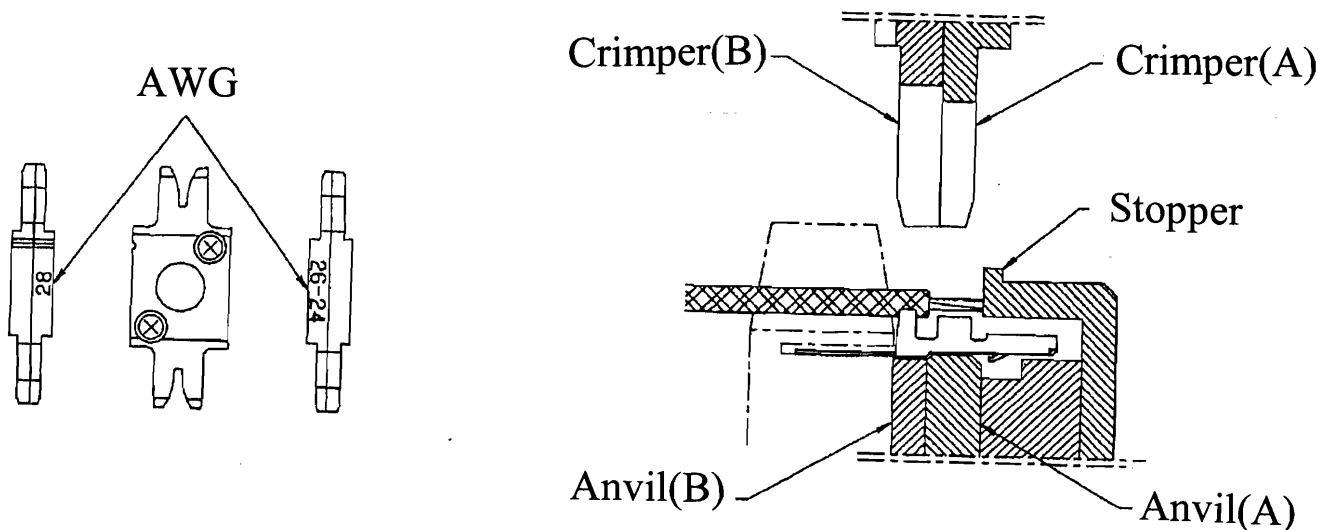

- Check the crimp appearance and tensile strength prior to use.
- Select the appropriate crimp position based on the wire size that will be used.
- The wire size in () above could cause excessive crimping. Check the tensile strength and crimp appearance to confirm an acceptable crimp.
- The insulation barrel is set for type of wire listed and is not adjustable.