

PART NUMBER	REV	FIRST USED
567839-1	D	854040-4

THIS DRAWING IS A CONTROLLED DOCUMENT.

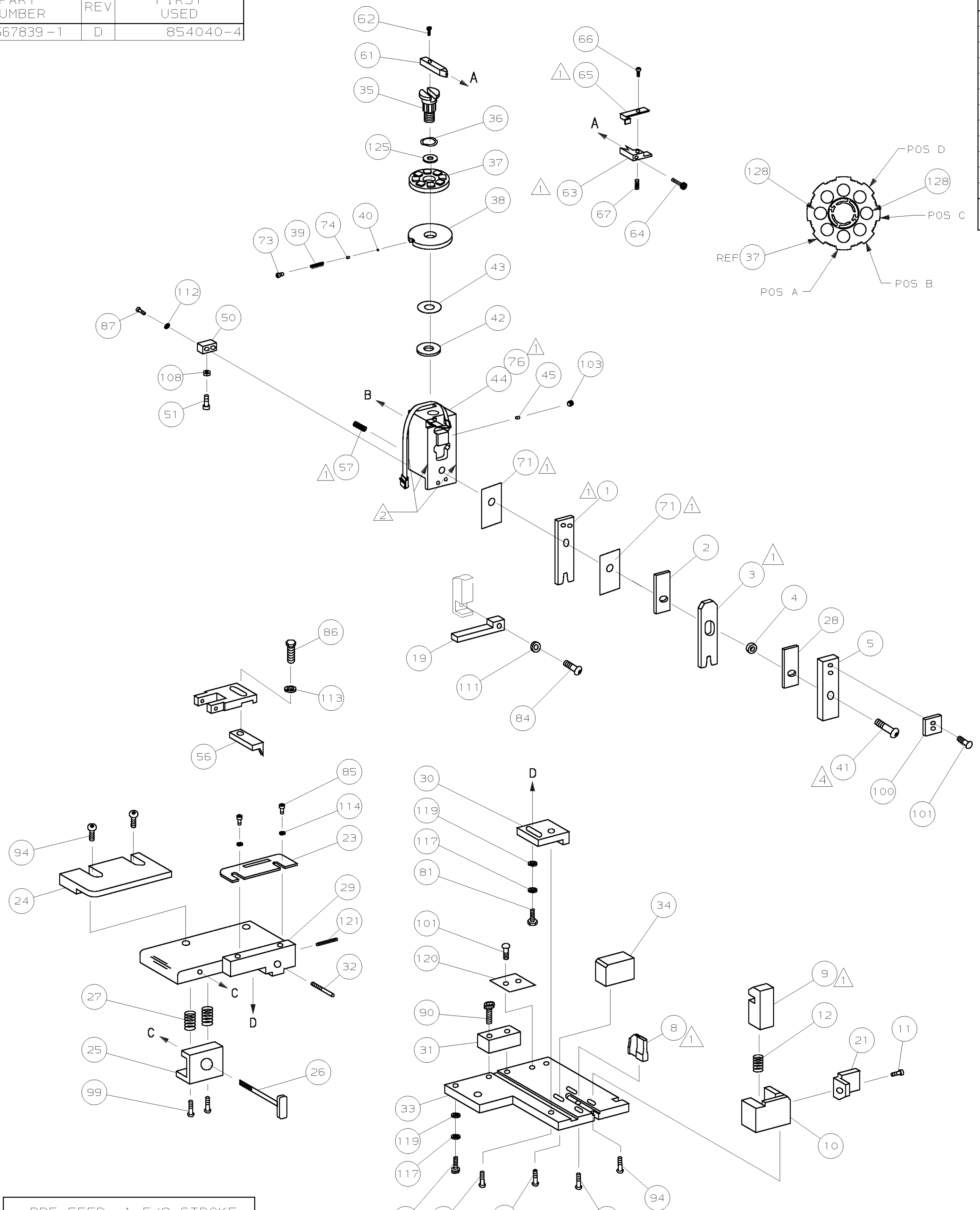

AMP P/N		MFG P/N		CRIMPING DATA			
318448		MX4-A-5CI-1-3500					
				CRIMP	SIZE	TYPE	RANGE
				WIRE	.078 [2.00mm]	F	0.75mm ²
				INSUL	.100 [2.54mm]	F	3-3.1 MM
WIRE STRIP LENGTH		TERM APPL	SPEC	FEED	APPL INSTRUCTION	SET UP GAGE	LAYOUT
			NONE	.472	SEE CUSTOMER MANUAL	NONE	L1670

QTY	REV	DESCRIPTION	ITEM NO		
2	-	C	4-354779-4	PIN, WIRE DISC (.3210)C	129
					128
					127
					126
					125
					124
					123
					122
1	-	A	4-21028-0	PIN, SLT SPR (#.093x.75) ST 60E PL	121
1	-	B	690701-2	PLATE, SERIAL NO.	120
2	-	A	21899-2	WASHER, FLAT (#10) 5 G ADJ BLK	119
					118
2	-	A	21024-5	WASHER, LOCK (#10) ADJ BLOCK	117
					116
					115
2	-	A	21024-2	WASHER, LOCK (#4) FRONT STP GUIDE	114
REF	-	A	21024-4	WASHER, LOCK (#8) FEED FINGER	113
2	-	A	21024-4	WASHER, LOCK (#8) DEP-HOLD	112
REF	-	A	21024-4	WASHER, LOCK (#8) STRIPPER	111
					110
					109
1	-	A	21018-5	NUT, HEX (#6) HOLD DOWN	108
					107
					106
					105
					104
1	-	A	21009-2	SCR, SKT 5ET (1/4-20x.25 LW) RAM	103
					102
4	-	A	21017-2	SCR, DRIVE (#2x.19) ID PLATE	101
1	-	B	819347-1	PLATE, IDENTIFICATION	100
2	-	A	3-21002-0	SCR, BHC (10-32x.88) DRAG	99
1	-	A	22733-8	SCR, BHC (8-32x.38 LW) ANVIL	98
					97
1	-	A	3-21000-8	SCR, SHC (10-32x.88) MOUNTING	96
1	-	A	2-21002-7	SCR, BHC (10-32x.50) 5G ADJ BLK	95
6	-	A	2-21002-2	SCR, BHC (8-32x.50) SHEAR-TERM SUP	94
					93
					92
					91
1	-	A	1-21002-7	SCR, SHC (6-32x.50) CAM	90
2	-	A	2-21000-7	SCR, SHC (8-32x.50) SCR BLK	89
					88
2	-	A	2-21000-7	SCR, SHC (8-32x.48) DEP-HOLD DOWN	87
REF	-	A	2-22603-0	SCR, HEX HD (8-32x.31) FEED FINGER	86
2	-	A	1-21000-3	SCR, SHC (4-40x.25) F ST GUIDE	85
REF	-	A	22733-9	SCR, BHC (8-32x.50 SL) STRIPPER	84
					83
					82
					81
1	-	A	3-22603-1	SCR, HEX (10-32x.38) 5G ADJ BL	80
					79
					78
2	-	B	463310-5	BLADE, STRIPPING (#20)	77
-	-	D	354440-3	FFC LOOP ASSY	76
					75
1	-	A	690603-1	SPRING, ASSIST	74
1	-	A	23030-1	SCR, SKT CAP (6-32x.25) CP DISC	73
					72
2	-	B	853495-1	GASKET	71

STANDARD FORCE CRIMP QUALITY MONITOR APPLICATOR
SIM TO HDM 680193

QTY	REV	DESCRIPTION	ITEM NO		
			70		
			69		
			68		
1	-	A	2-21010-7	SCR, SET (6-32x.12) LIFT ARM	67
1	-	B	1-21002-6	SCR, BHC (6-32x.25) LEVER	66
1	-	B	856044-1	LEVER, SLIDE LOCK	65
1	-	A	2-21000-0	SCR, SHC (6-32x.50) LIFT ARM	64
1	-	B	856043-1	ARM, LIFT	63
1	-	A	2-21000-6	SCR, SHC (8-32x.38) EXT ARM	62
1	-	B	856042-1	ARM, EXTENSION	61
					60
					59
					58
1	-	A	7-21013-3	SCR, SET (5/16x.38) CR BOLT	57
REF	-	B	694433-8	PAWL, FEED	56
					55
					54
					53
					52
					51
1	-	A	811242-2	BUMPER, HOLDDOWN	50
1	-	A	690753-1	SPACER, TONKER	49
					48
1	-	A	690602-6	CAM, PRE-FEED 1.62 STROKE	47
					46
					45
1	-	A	690191-1	PLUG, NYLON	44
1	-	C	853493-4	SIDE FEED RAM ASSY	43
1	-	A	690125-1	WASHER, LAMINATED	42
1	-	A	690124-1	WASHER, RAM	41
1	-	A	7-21002-9	BOLT, CRIMPER (5/16x1.00)	40
1	-	A	23241-6	BALL, STEEL	39
1	-	A	690170-1	SPRING, COMPRESSION	38
1	-	C	690142-4	DISC, INSULATION	37
1	-	D	354777-1	WIRE DISC, PLASTIC	36
1	-	A	22480-5	WASHER, SPRING	35
1	-	B	856041-1	POST, RAM	34
1	-	B	690786-1	SUPPORT, TERMINAL	33
1	-	C	462544-1	PLATE, BASE SPECIAL	32
1	-	A	690432-3	SCREW, ADJUSTMENT	31
1	-	B	462543-1	BLOCK, SCREW SPECIAL	30
1	-	B	455689-1	BLOCK, STRIP GUIDE ADJ	29
1	-	C	455671-1	PLATE, STRIP GUIDE	28
1	-	C	2-455888-2	SPACER, FRONT SHEAR DEP	27
2	-	A	1-22284-0	SPRING, DRAG	26
1	-	B	690546-1	LEVER, DRAG RELEASE	25
1	-	B	240792-1	DRAG, TERMINAL	24
1	-	D	6-690504-8	GUIDE, STRIP (REAR)	23
1	-	A	690438-1	GUIDE, STRIP (FRONT)	22
					21
1	-	A	463756-1	GUIDE, SCRAP	20
REF	-	C	462615-1	STRIPPER	19
					18
					17
					16
					15
					14
					13
1	-	A	5-22280-0	SPRING, SHEAR	12
1	-	B	690461-2	STOP, SHEAR (FRONT)	11
1	-	B	462548-1	HOLDER, SHEAR (FRONT) SP	10
1	-	B	462547-2	SHEAR, FLOAT (FRONT) SP	9
1	-	C	3-189717-4	ANVIL	8
					7
					6
1	-	A	462838-1	DEPRESSOR, SHEAR (FRONT) SP	5
1	-	B	1-238011-6	SPACER, BLOCK CRIMPER	4
1	-	C	7-683453-4	CRIMPER, INSULATION	3
1	-	C	455888-5	SPACER, CRIMPER	2
1	-	C	2-568176-1	CRIMPER, WIRE	1

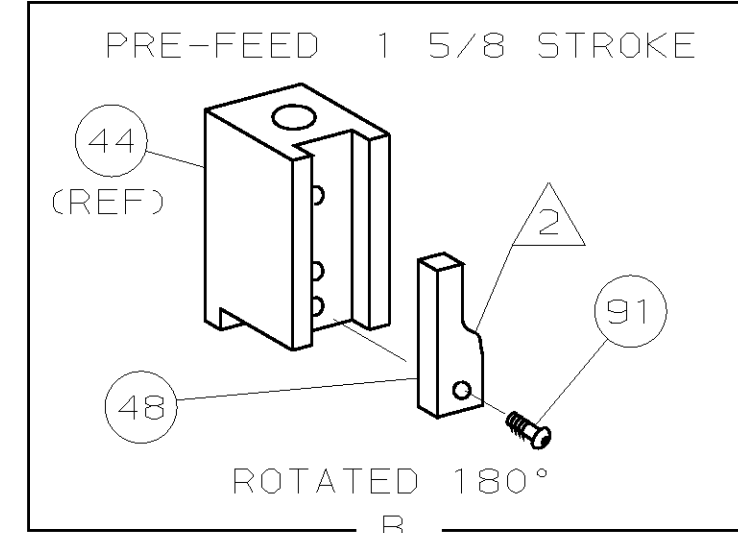

- ▲1 RECOMMENDED SPARE PARTS.
- ▲2 GREASE LIGHTLY.
- ▲3 ITEM NOT SHOWN
- ▲4 TORQUE ITEM 41 TO 60 INCH POUNDS

QTY	REV	DESCRIPTION	ITEM NO
-1	U/M	DWG SIZE	REVISION OF EACH ASSY NO (WHEN BLANK, USE DWG REVISION)

PARTS LIST		
MATL	HT TR	FIN
-	-	-

D1	ECN 0150-0458-04	TE	4-04
D	0150-0127-01	CE	FEB01
C	0150-7147-96	CE	8-96
B	0150-7052-96	TB	8/96
A	REVISED	CE	5-96

DR	J.BAKER	3/21/96	APP	T.ELBIN	3/21/96
CHK	C.ERISMAN	6/10/96	REL	B.MORGAN	6/10/96

NAME	CQM STRIPPER CRIMPER APPLICATOR	MACHINE REF	STRIPPER CRIMPER
SCALE	D	DWG NO	567839
SHEET	1 OF 1	REV	D1

CUSTOMER AND ASSEMBLY DRAWING 1