

REVISIONS							
LOC	QIST	P	F	ZONE	LTR	DESCRIPTION	
CM	53				C	REV & REDWN PER CM-11	
						DATE	APPD
						11-4-93	KW

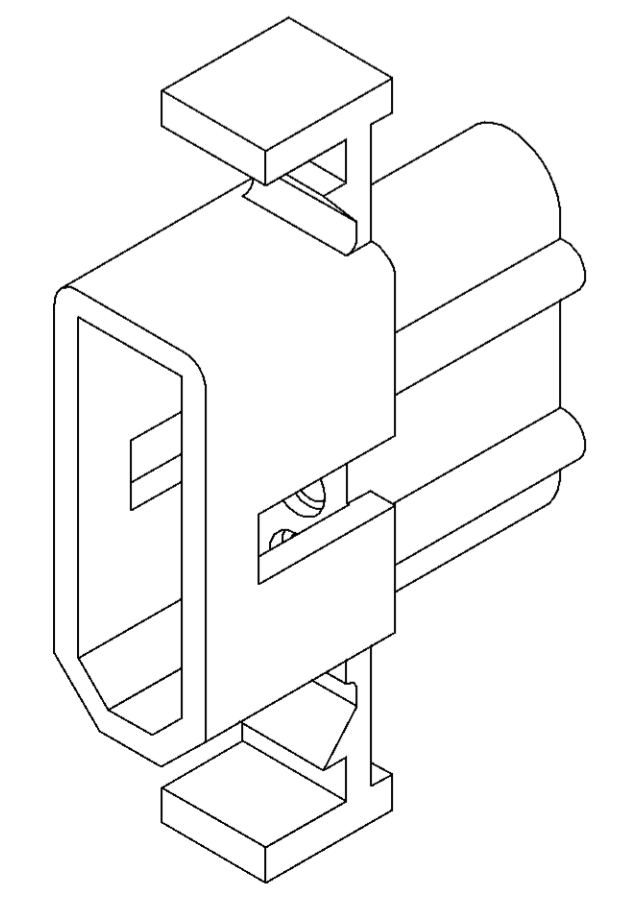
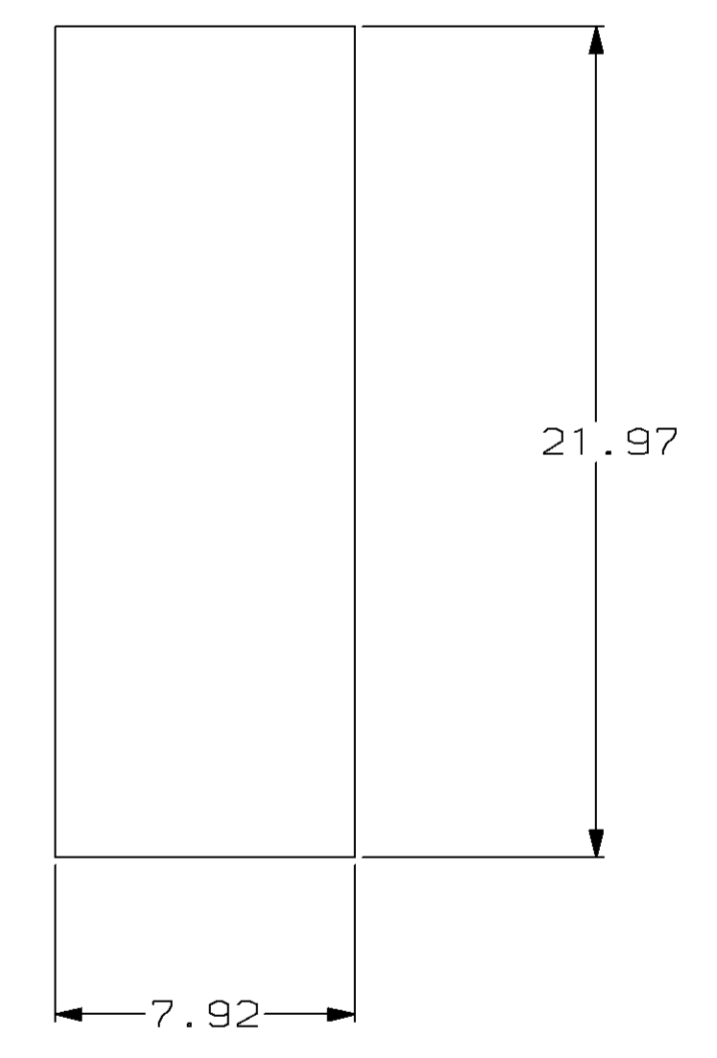
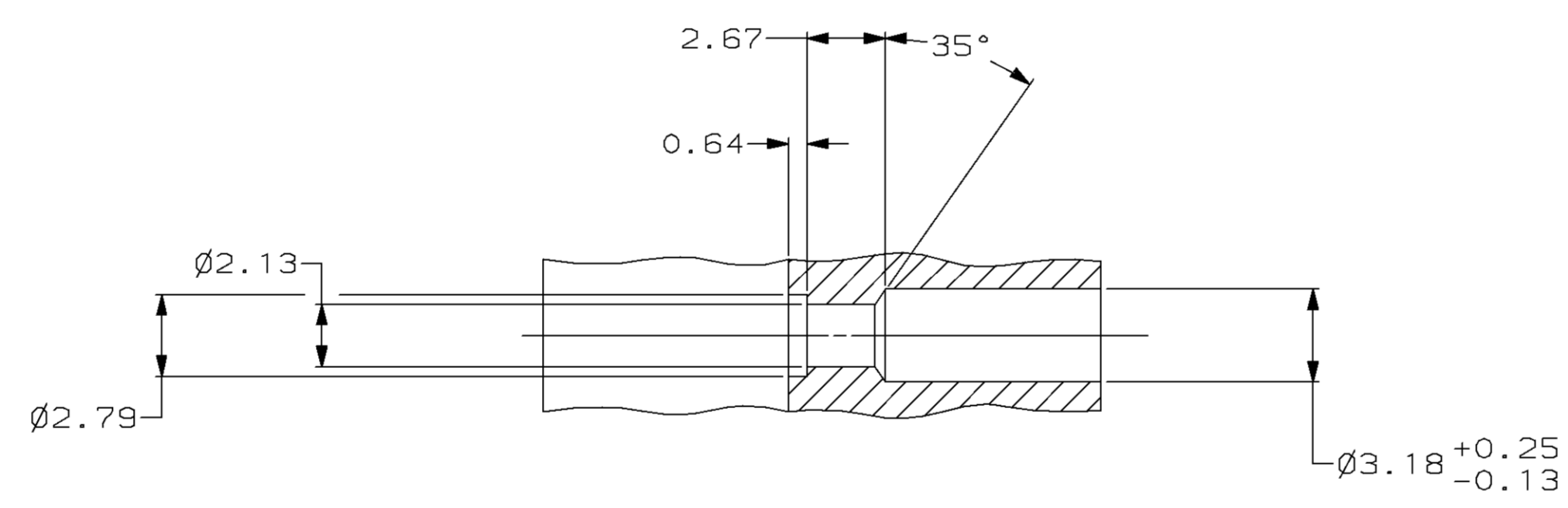
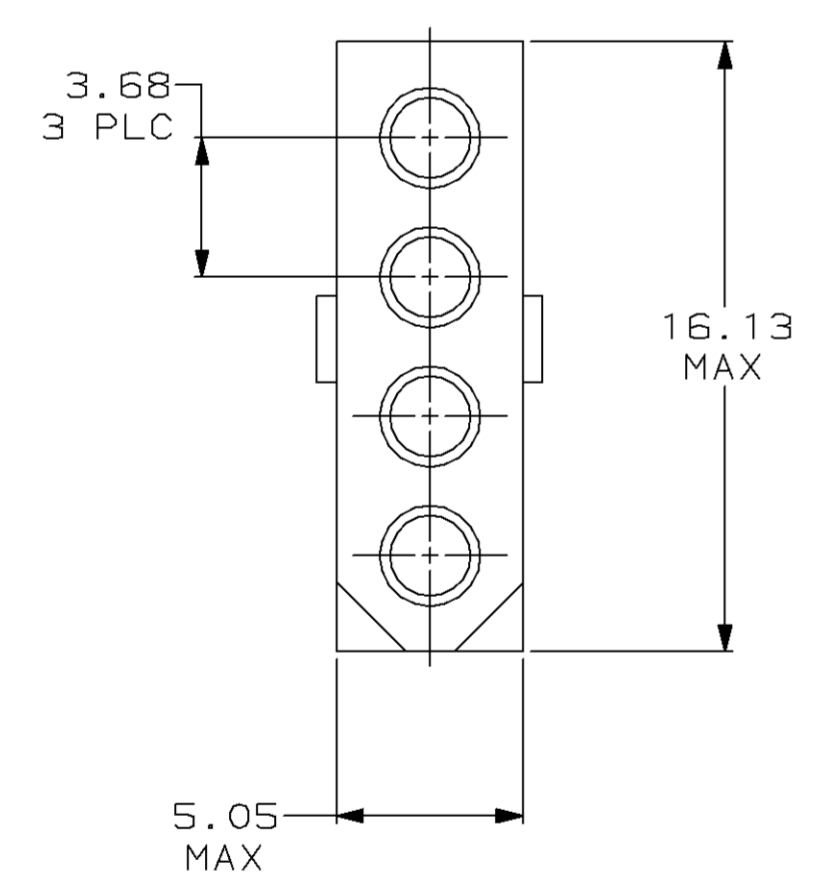
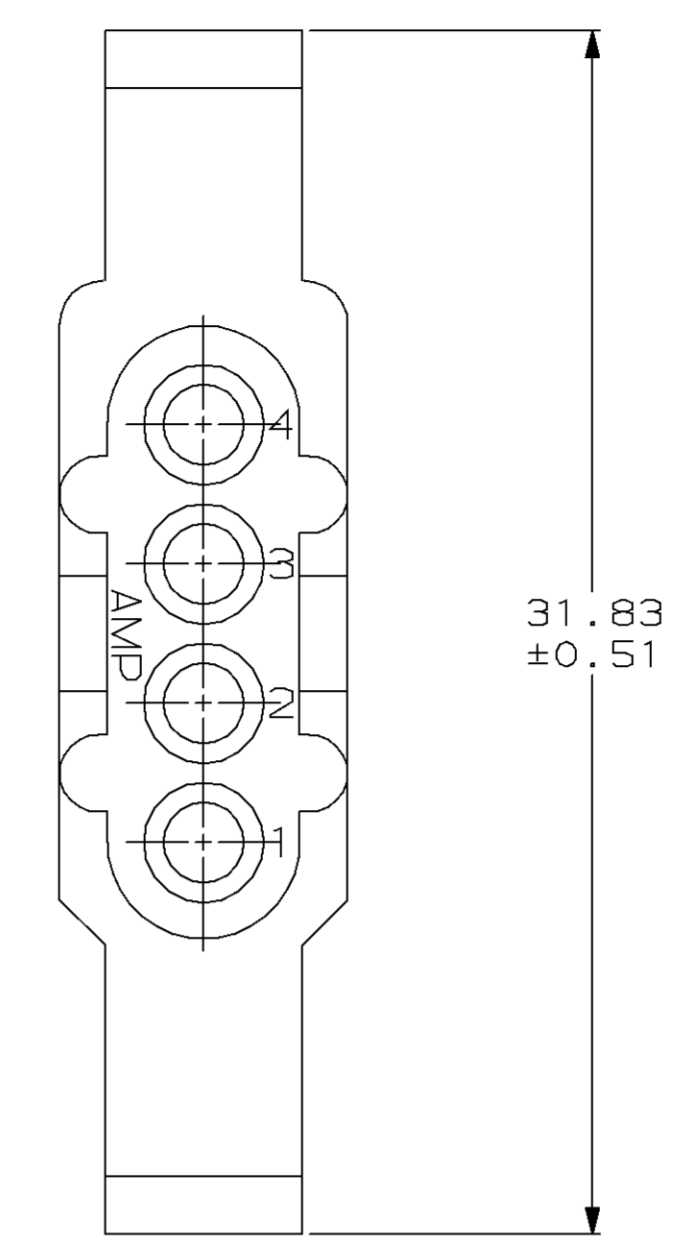
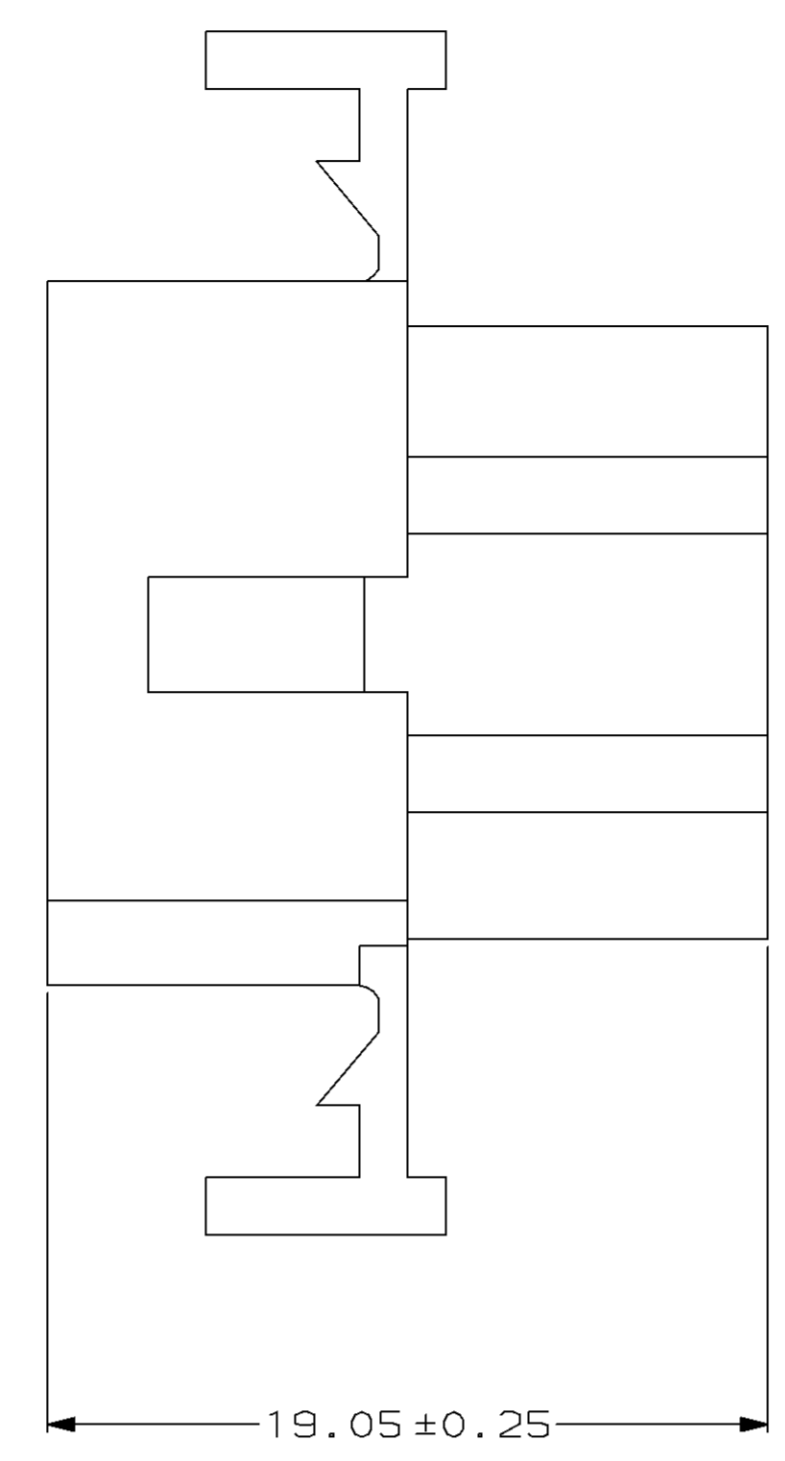
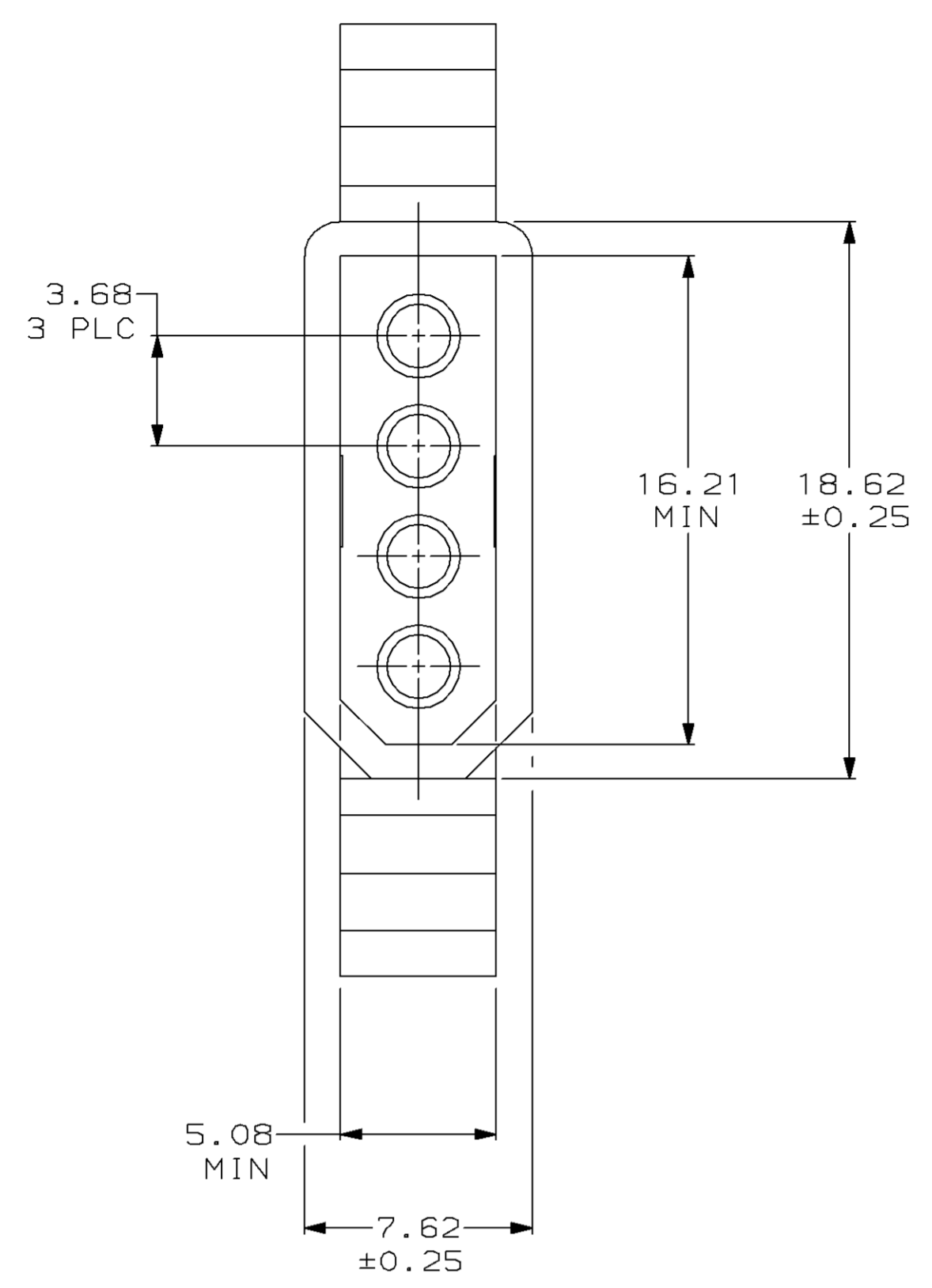

MATING CONNECTOR INTERFACE

TYPICAL PLUG CAVITY SECTION (DIMENSIONS REFERENCE ONLY)

RECOMMENDED CUT OUT FOR 1.52 MAX THICK PANEL

MM	IN	MM	IN	MM	IN
2.13	.084	7.62	.300	31.83	1.253
1.57	.062	5.08	.200	21.97	.865
1.52	.060	5.05	.199	19.05	.750
0.64	.025	3.68	.145	18.62	.733
0.51	.020	3.18	.125	16.21	.638
0.25	.010	2.79	.110	16.13	.635
0.13	.005	2.67	.105	7.92	.312

CONVERSION TABLE

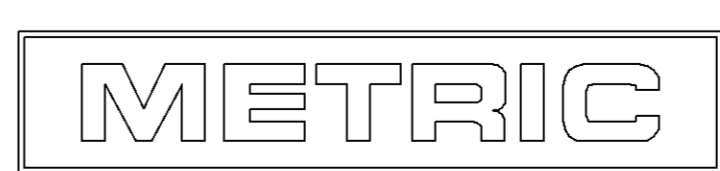

THIS DRAWING IS A CONTROLLED DOCUMENT FOR AMP INCORPORATED. IT IS SUBJECT TO CHANGE AND THE CONTROLLING ENGINEERING ORGANIZATION SHOULD BE CONTACTED FOR THE LATEST REVISION.

DO NOT SCALE PRINT. UNLESS SPECIFIED DIMENSIONS IN mm [INCHES] TOLERANCES ON : 2 PLC DEC ± 0.13 3 PLC DEC ± .		DR 11-4-93 K. WHITAKER	770334-1 PART NO		
MATERIAL	NYLON, UL 94V-2 NATURAL	CHK 11-4-93 R. SWING	AMP Incorporated Harrisburg, PA 17105-3608		
FINISH	-	APPD 11-4-93 C. CASH	NAME PLUG, PANEL MOUNT, 4 CIRCUIT, .062 PIN AND SOCKET		
WEIGHT	-	APPD 11-4-93 C. CASH	SIZE	CAGE CODE	DRAWING NO
		PRODUCT SPEC	Ⓟ	00779	©-770334
		APPLICATION SPEC	SCALE	5:1	SHEET 1 OF 1