

VICOR CONFIDENTIAL

THIS DOCUMENT AND THE DATA DISCLOSED
HEREIN OR HEREWITH IS NOT TO BE REPRODUCED,
USED, OR DISCLOSED IN WHOLE OR IN PART
TO ANYONE WITHOUT PERMISSION OF VICOR CORP.

REV.	DESCRIPTION	DATE	APVD
1	RELEASED PER E071481	JS 07/17/07	REJH
2	REVISED PER E072906	JS 11/21/07	REJH

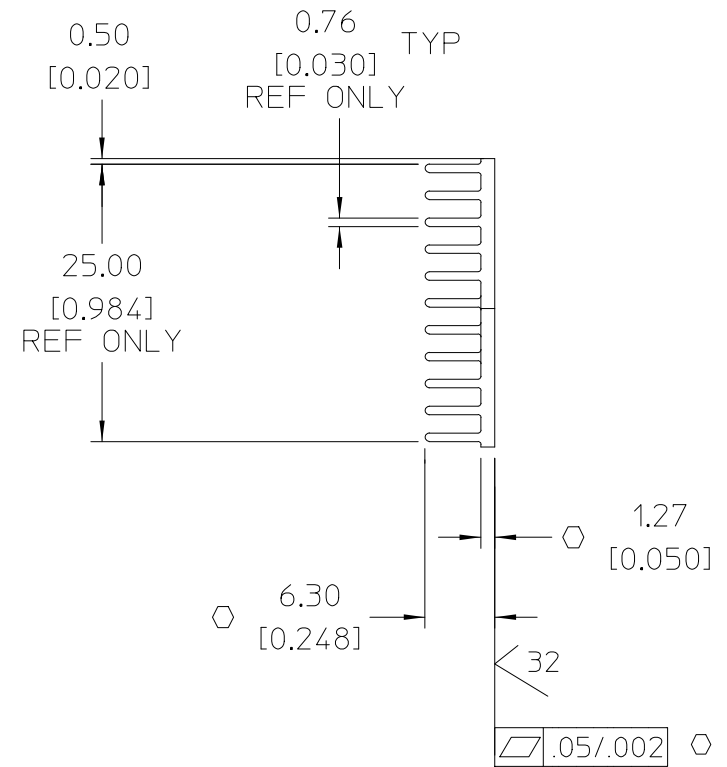
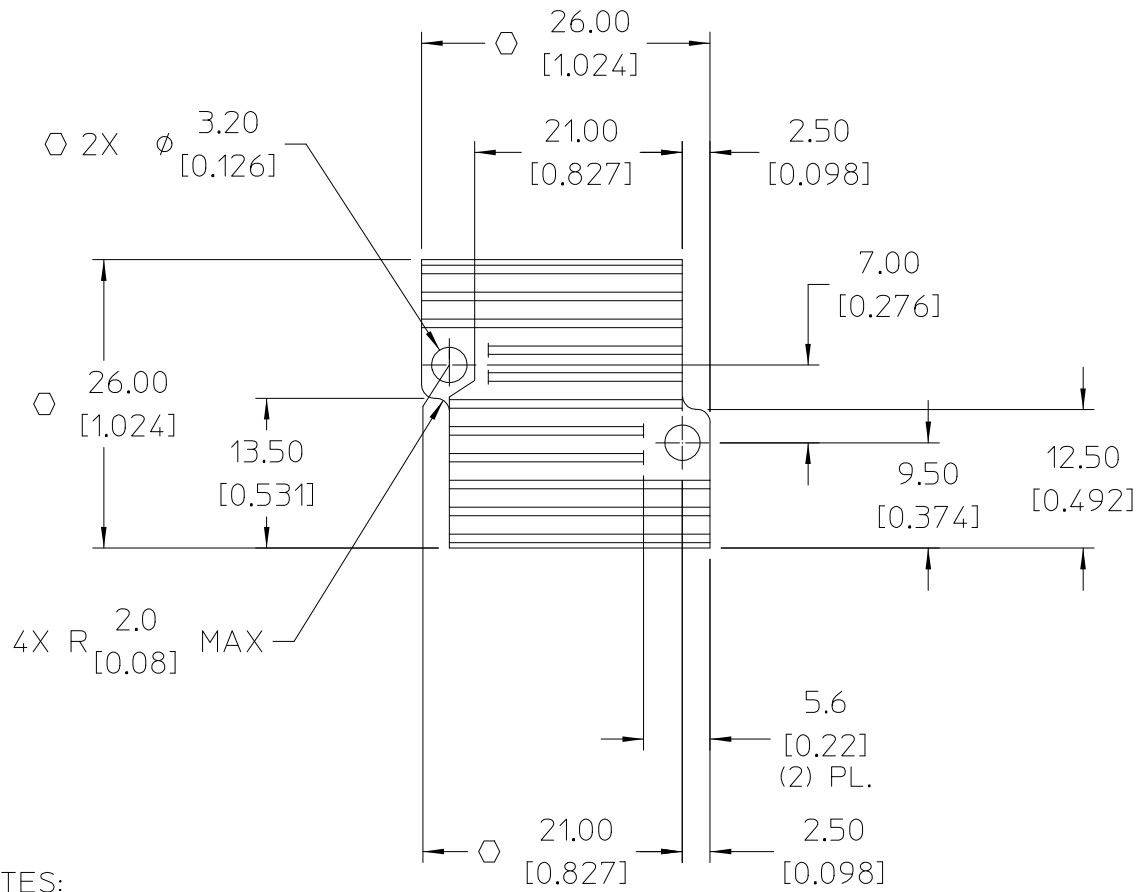

- NOTES:
1. MAKE FROM VICOR P/N 29804
 2. FINISH: ELECTROLESS NICKEL PLATE PER ASTM B607-91.
THICKNESS .000120" TO .000300" (3 TO 8 μm).
 3. REMOVE ALL BURRS AND SHARP EDGES
 4. "O" DENOTES CRITICAL CHARACTERISTIC FOR LOT INSPECTION
 5. RoHS COMPLIANT, LEAD FREE PER CST-0001 LATEST REVISION

DRAWN BY <i>D. CVINAR</i>	DATE <i>06/05</i>			
UNLESS OTHERWISE SPECIFIED DIMENSIONS ARE MM (INCH) TOLERANCES ARE: DECIMALS ANGLES X.XX=±0.25 [0.01] ±1° X.XXX=±0.127 [0.005]				
THIRD ANGLE PROJECTION 	SIZE B	FSCM NO. 67131	DWG NO 30384	REV 2
DO NOT SCALE DRAWING		SCALE 2:1	SHEET 1 OF 1	