

THIS DRAWING IS UNPUBLISHED. RELEASED FOR PUBLICATION ,19 .
 © COPYRIGHT 19 BY AMP INCORPORATED. ALL INTERNATIONAL RIGHTS RESERVED.

LOC	DIST	P	F	ZONE	LTR	DESCRIPTION	DATE	APPD
G	86				J	REVISED & REDRAWN PER 0720-0619-95	05JUN95	OKS AJK

METRIC
 DIMENSIONS LISTED IN mm [INCHES]

△ STAMP AMP 12-10 AL90CU APPROX AS SHOWN

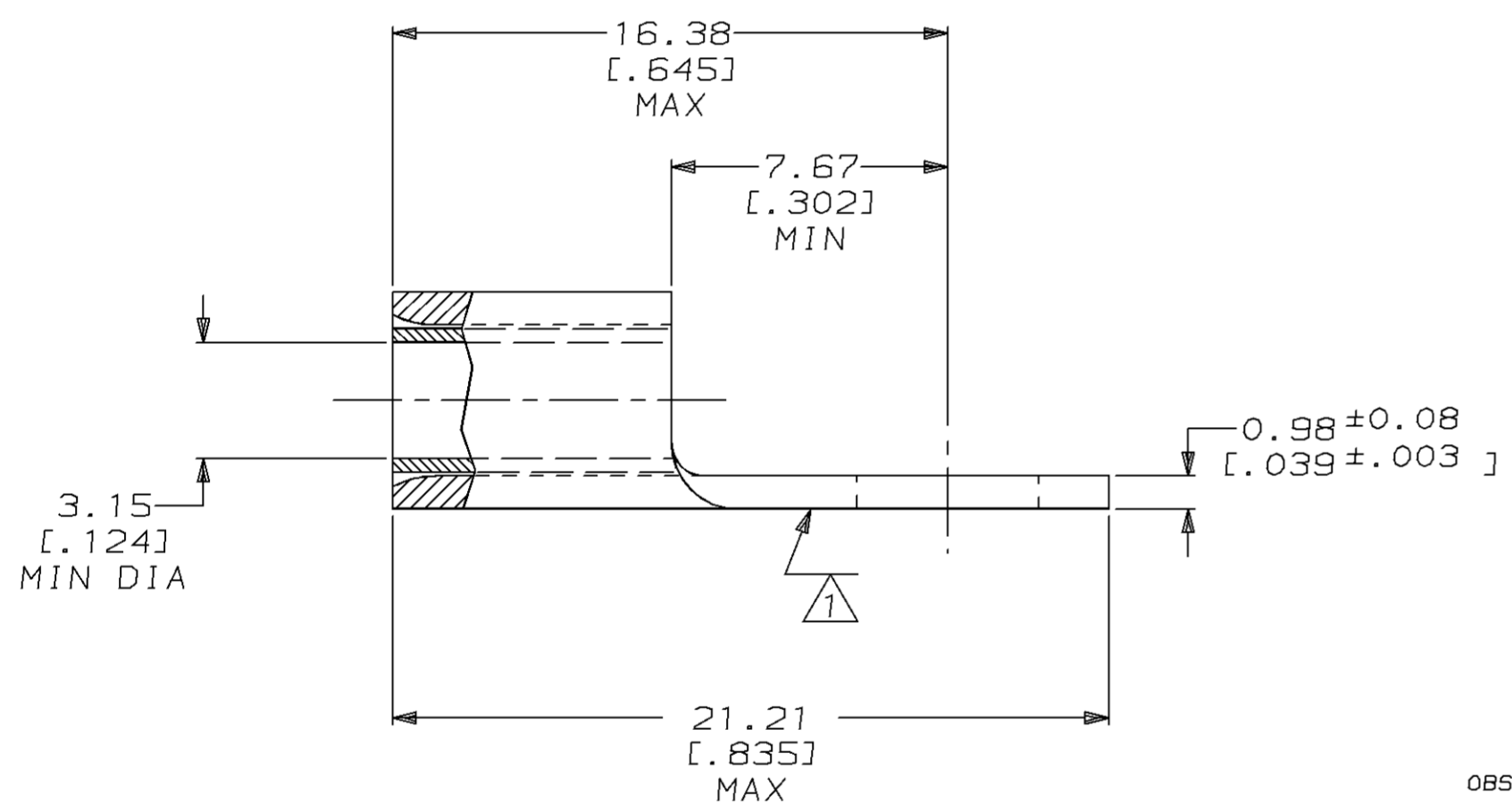
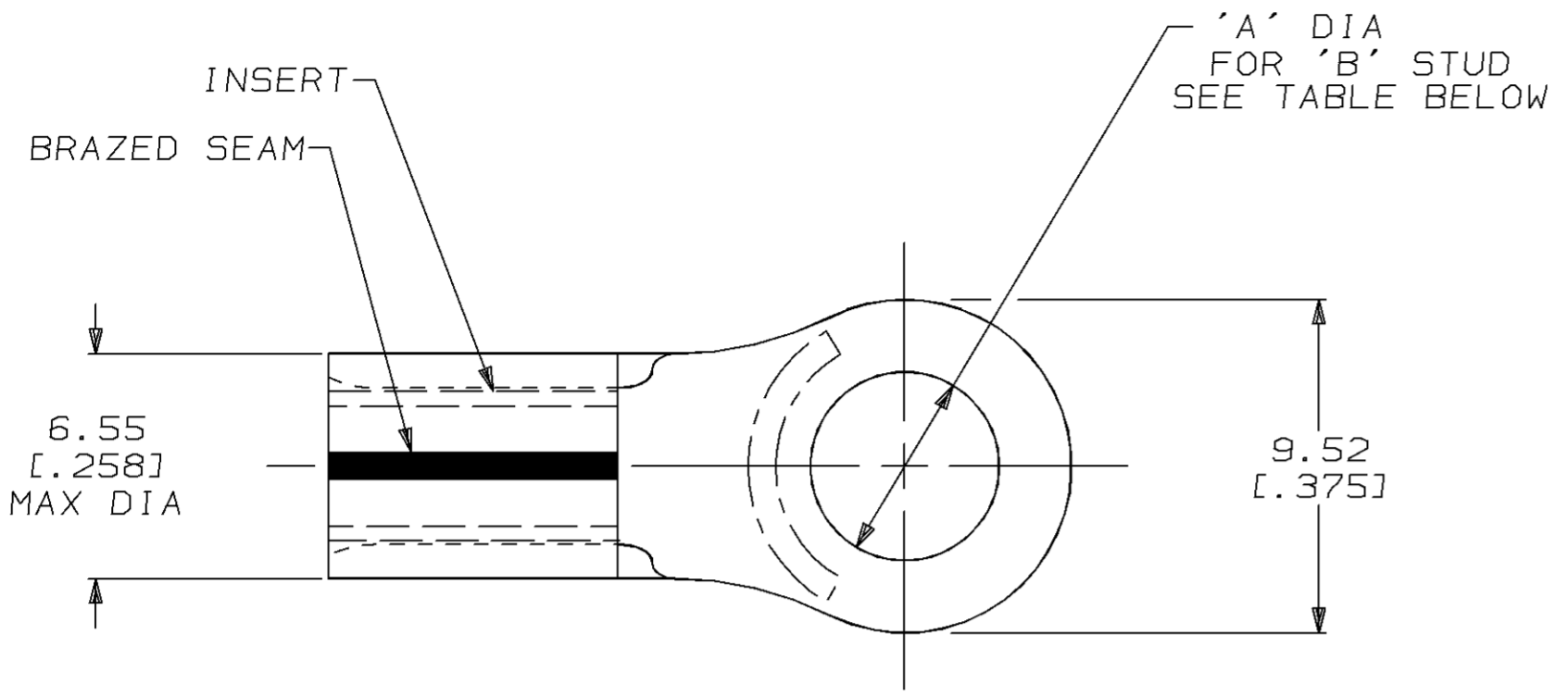

OBsolete		BODY:	PART NO
		COPPER PER ASTM B-152 TIN PL 0.00381 [.000150] MIN THK PER MIL-T-10727	51979-4
6.73±0.13 [.265±.005]	1/4		51979-3
5.00±0.08 [.197±.003]	#10		51979-2
4.34±0.08 [.171±.003]	#8	INSERT: BRASS PER MIL-C-50 TIN PL 0.00381 [.000150] MIN THK PER MIL-T-10727	51979-1
3.68±0.08 [.145±.003]	#6		51979
'A'	'B'	MATERIAL & FINISH	PART NO

AMP INCORPORATED
CUSTOMER SERVICE SYSTEMS

FOR ADDITIONAL PRODUCT INFORMATION OR COPIES OF DRAWINGS AND TECHNICAL DOCUMENTS
 PRODUCT INFORMATION CENTER
 1-800-522-6752

FOR APPLICATION TOOLING INFORMATION
 TOOLING ASSISTANCE CENTER
 1-800-722-1111

FOR ORDER ENTRY
 1-800-526-5142

MAX RECOMMENDED OPERATING TEMPERATURE:
 170°C MAX

VOLTAGE RATING:
 NOT APPLICABLE

WIRE CROSS SECTIONAL AREA RANGE:
 2.62-6.64mm² [5,180-13,100] CIR MILS
 SOLID OR STRANDED

THIS DRAWING IS A CONTROLLED DOCUMENT FOR AMP INCORPORATED. IT IS SUBJECT TO CHANGE AND THE CONTROLLING ENGINEERING ORGANIZATION SHOULD BE CONTACTED FOR THE LATEST REVISION.

DO NOT SCALE PRINT. UNLESS SPECIFIED DIMENSIONS IN mm [INCHES] - TOLERANCES ON:
 2 PLC DEC ± -
 3 PLC DEC ± -
 ANGLES ± -

MATERIAL
 SEE TABLE

FINISH
 SEE TABLE

DR 05JUN95 DK SCHRUM
 CHK 07JUN95 AJ KAUFMAN
 APPD 07JUN95 RE ROSER
 APPD 07JUN95 JL MECKLEY
 PRODUCT SPEC -
 APPLICATION SPEC -
 WEIGHT -

AMP AMP Incorporated
 Harrisburg, PA 17105-3608

NAME
 TERMINAL, RING TONGUE,
 STRANDED/SOLID, COPALUM™,
 WIRE SIZE: 12-10 AWG

SIZE CAGE CODE DRAWING NO
 C 00779 C=51979

SCALE 5:1 SHEET 1 OF 1