

THIS DRAWING IS UNPUBLISHED. RELEASED FOR PUBLICATION  
 © COPYRIGHT - By - ALL RIGHTS RESERVED.

LOC	DIST	REVISIONS			
P	LTR	DESCRIPTION	DATE	DWN	APVD
GP	00				
	P2	REVISED PER ECO-12-011709	25JUN12	RW	SY

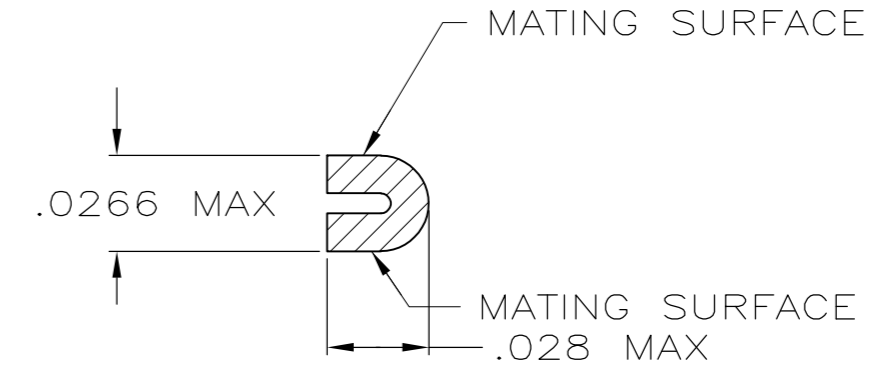

SECTION B-B

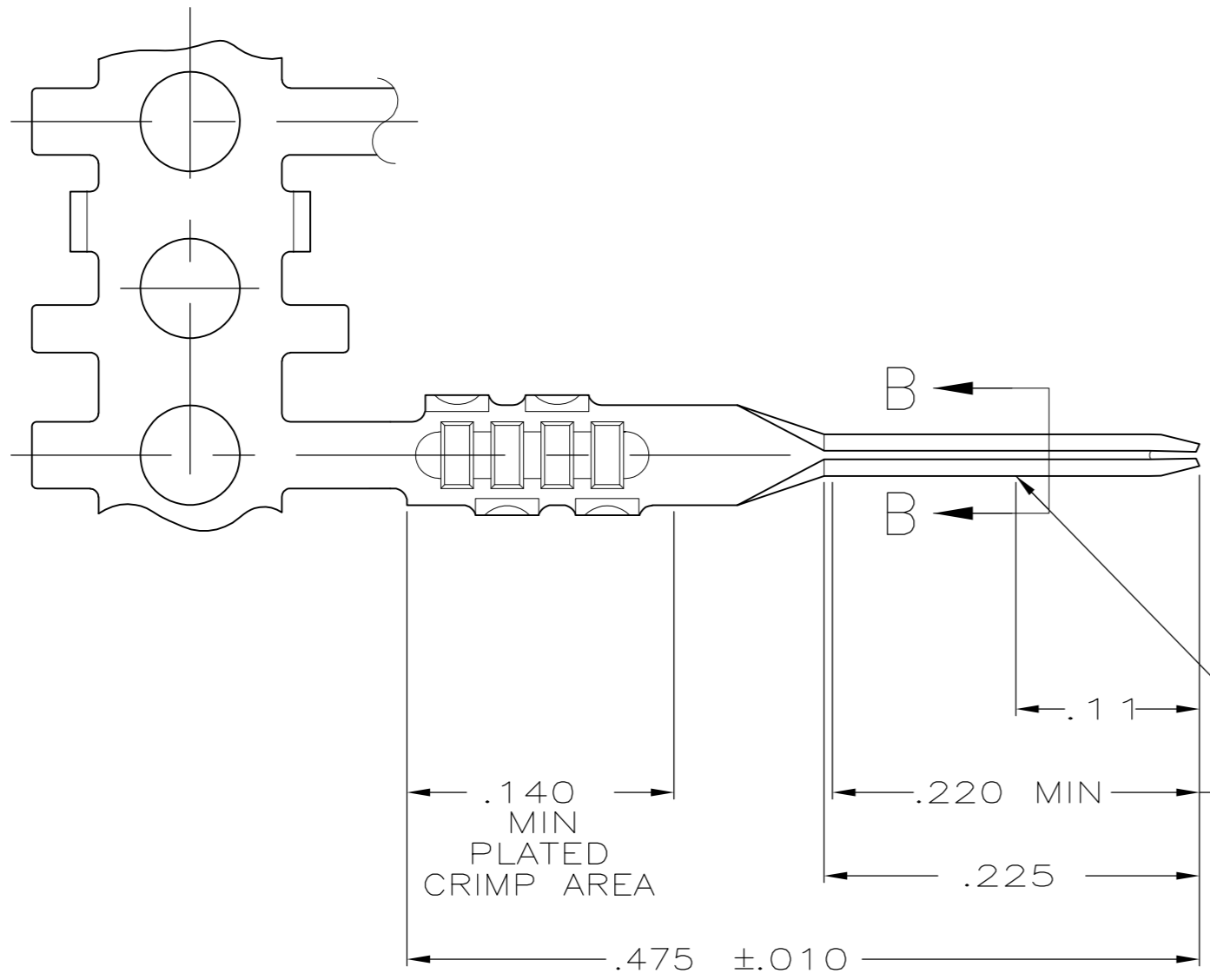
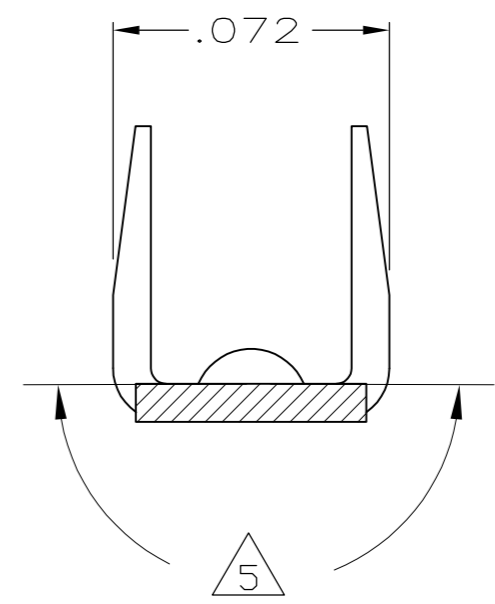
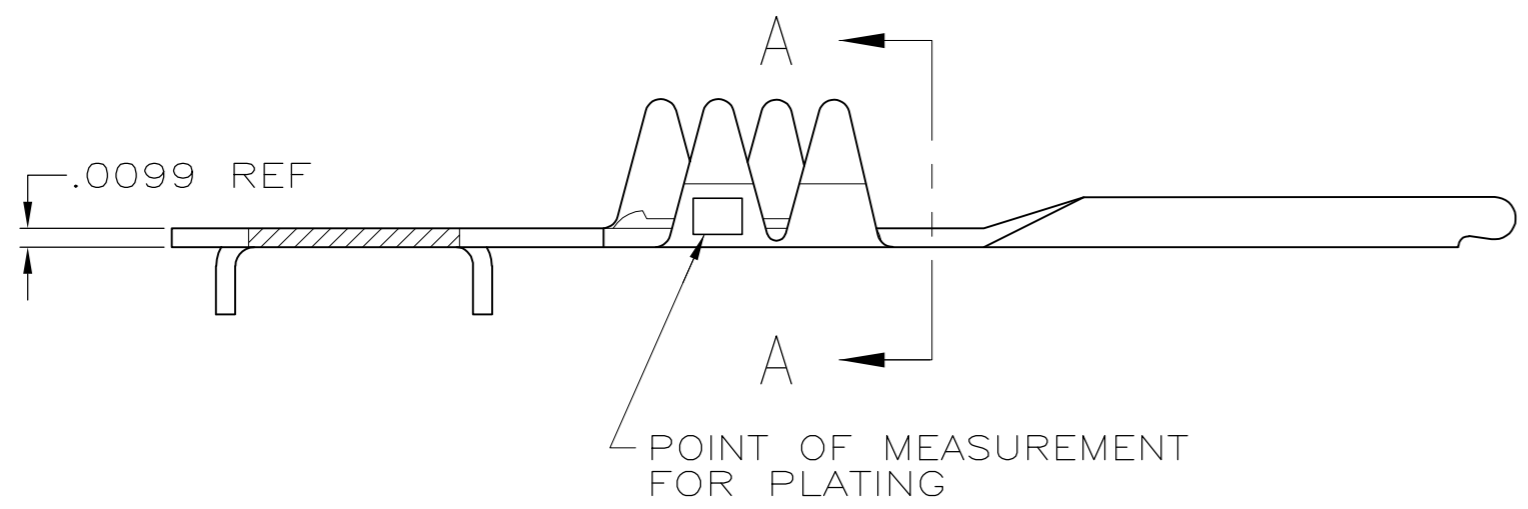

SECTION A-A

- 1 NICKEL UNDERPLATE .000050 MIN THK ON ENTIRE CONTACT WITH GOLD .000015 THK ON LOCALIZED PLATE AREA AND BRIGHT TIN-LEAD .000100 MIN THK IN CRIMP AREA
- 2 BRIGHT TIN-LEAD .000100 MIN THK OVER NICKEL UNDERPLATE .000050 MIN THK ON ENTIRE CONTACT
- 3 GOLD FLASH IN PLATED CRIMP AREA, .00015 MIN GOLD ON LOCALIZED PLATE AREA, BOTH OVER .000050 MIN NICKEL ON ENTIRE CONTACT, -OR- GOLD FLASH OVER PALLADIUM-NICKEL, .000015 MIN TOTAL THK ON LOCALIZED PLATE AREA AND GOLD FLASH ON PLATED CRIMP AREA, BOTH OVER .000050 MIN NICKEL ON ENTIRE CONTACT.
- 4 GOLD FLASH IN PLATED CRIMP AREA, .00100 MIN TIN IN LOCALIZED PLATE AREA, BOTH OVER .000050 MIN NICKEL ON ENTIRE CONTACT.
- 5 GOLD PLATING MAY OR MAY NOT BE PRESENT ON THE BOTTOM OF THE CRIMP BARREL IN THIS AREA.

5	3	88976-5
5	4	88976-4
SUPERSEDED BY 88976-5		1
		2
FINISH		PART NO

THIS DRAWING IS A CONTROLLED DOCUMENT.		DWN P.BERRY 3-21-86	<b>TE</b> TE Connectivity	
DIMENSIONS: INCHES		CHK D.WORTHINGTON 3-24-86		
TOLERANCES UNLESS OTHERWISE SPECIFIED:		APVD R. SMITH 3-25-86	NAME CONTACT, FFC .100CL, .025 SQ PIN	
0 PLC ± -		PRODUCT SPEC 108-9024	SIZE CAGE CODE DRAWING NO RESTRICTED TO	
1 PLC ± -		APPLICATION SPEC 114-16015	A2 00779 C-88976	
2 PLC ± .02		WEIGHT -	SCALE NTS SHEET 1 of 1 REV P2	
3 PLC ± .005		MATERIAL PHOS BRONZE	CUSTOMER DRAWING	
4 PLC ± -		FINISH SEE TABLE		
5 ANGLES ± -				