



The following document contains information on Cypress products. Although the document is marked with the name “Broadcom”, the company that originally developed the specification, Cypress will continue to offer these products to new and existing customers.

CONTINUITY OF SPECIFICATIONS

There is no change to this document as a result of offering the device as a Cypress product. Any changes that have been made are the result of normal document improvements and are noted in the document history page, where supported. Future revisions will occur when appropriate, and changes will be noted in a document history page.

CONTINUITY OF ORDERING PART NUMBERS

Cypress continues to support existing part numbers. To order these products, please use only the Ordering Part Numbers listed in this document.

FOR MORE INFORMATION

Please visit our website at www.cypress.com or contact your [local sales office](#) for additional information about Cypress products and services.

OUR CUSTOMERS

Cypress is for true innovators – in companies both large and small.

Our customers are smart, aggressive, out-of-the-box thinkers who design and develop game-changing products that revolutionize their industries or create new industries with products and solutions that nobody ever thought of before.

ABOUT CYPRESS

Founded in 1982, Cypress is the leader in advanced embedded system solutions for the world’s most innovative automotive, industrial, home automation and appliances, consumer electronics and medical products. Cypress’s programmable systems-on-chip, general-purpose microcontrollers, analog ICs, wireless and USB-based connectivity solutions and reliable, high-performance memories help engineers design differentiated products and get them to market first.

Cypress is committed to providing customers with the best support and engineering resources on the planet enabling innovators and out-of-the-box thinkers to disrupt markets and create new product categories in record time. To learn more, go to www.cypress.com.

Not Recommended for New Designs

Single-Chip IEEE 802.11 a/b/g/n 2x2 MAC/Baseband/Radio with Integrated Bluetooth 4.0 + HS and FM Receiver

GENERAL DESCRIPTION

The Broadcom® BCM43241 single-chip device provides the highest level of integration for a mobile or handheld wireless system, with integrated IEEE 802.11 a/b/g and 2x2 IEEE 802.11n MAC/baseband/radio, Bluetooth 4.0 + HS, and FM radio receiver.

The BCM43241 takes advantage of the high throughput and extended range of the Broadcom second-generation MIMO solution. With MIMO, the information is sent and received over two or more antennas, simultaneously using the same frequency band, thus providing greater range and higher throughput, while maintaining compatibility with legacy IEEE 802.11a/b/g devices. This is accomplished through a combination of enhanced MAC and PHY implementations including spatial multiplexing modes in the transmitter and receiver, and advanced digital signal processing techniques to improve receive sensitivity. The BCM43241 architecture with its fully integrated dual-band radio transceiver supports 2 x 2 antennas. It also supports 20 and 40 MHz channels allowing for PHY Layer throughput up to 300 Mbps.

Using advanced design techniques and process technology to reduce active and idle power, the BCM43241 is designed to address the needs of highly mobile devices that require minimal power consumption and compact size.

GENERAL DESCRIPTION

It includes a power management unit that simplifies the system power topology and allows for operation directly from a mobile platform battery while maximizing battery life. The BCM43241 also includes power saving schemes such as single-core listen (OCL), single-core demodulation of SISO/STBC packets, and Dynamic ML.

The BCM43241 implements the highly sophisticated Enhanced Collaborative Coexistence radio coexistence algorithms and hardware mechanisms, allowing for an extremely collaborative Bluetooth coexistence scheme along with coexistence support for external radios (such as GPS, WiMAX, or Ultra Wideband radio technologies, as well as cellular radios) and a single shared 2.4 GHz antenna for Bluetooth and WLAN. As a result, enhanced overall quality for simultaneous voice, video, and data transmission on a handheld system is achieved.

For the WLAN section, two alternative host interface options are included: an SDIO v3.0 interface, which can operate in 4 bit, 1 bit, or gSPI modes, and a High-Speed Inter-Chip (HSIC) interface (a USB 2.0 derivative for short-distance on-board connections). An independent, high-speed UART is provided for the Bluetooth host interface.

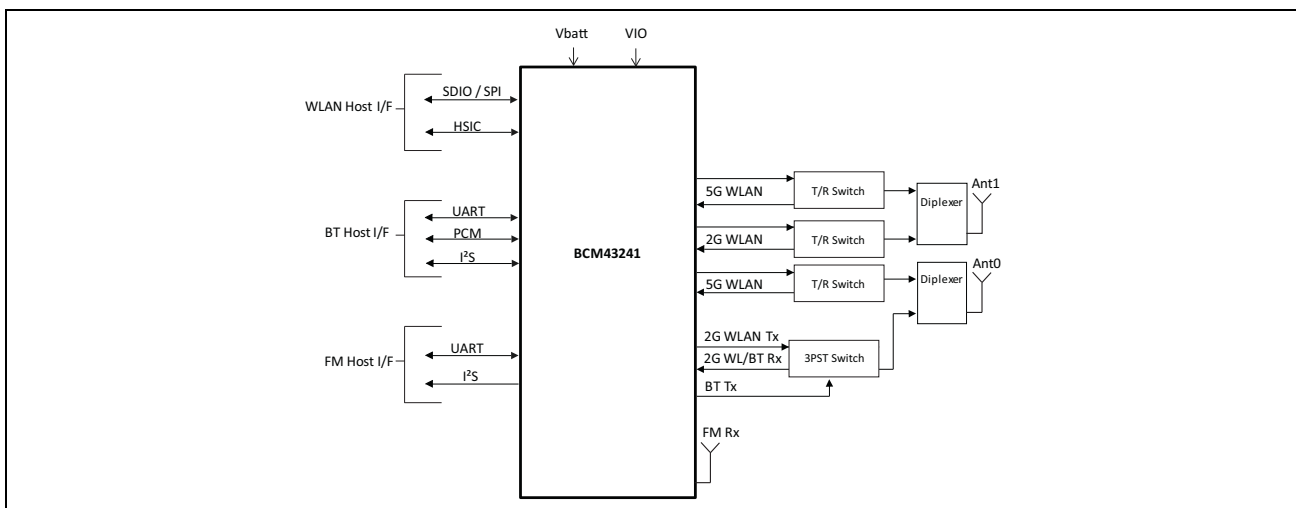

Figure 1: Functional Block Diagram

Not Recommended for New Designs

FEATURES**IEEE 802.11x Key Features**

- Single-band 2.4 GHz IEEE 802.11 b/g/n or dual-band 2.4 GHz and 5 GHz IEEE 802.11 a/b/g/n
- Hardware support for virtual simultaneous dual band operation with sub 1 ms band switching time
- Dual-stream IEEE 802.11n support for 20 MHz and 40 MHz channels provides PHY layer rates up to 300 Mbps for typical upper-layer throughput in excess of 200 Mbps
- Supports the IEEE 802.11n STBC (space-time block coding) in both TX and RX for improved range and power efficiency
- Contains integrated 2.4 GHz and 5 GHz Power Amplifiers as well as 11 RF control signals available to control external RF switches or LNAs
- Supports a single 2.4 GHz antenna shared between WLAN and Bluetooth
- Shared Bluetooth and WLAN receive signal path eliminates the need for an external power splitter while maintaining excellent sensitivity for both Bluetooth and WLAN
- Internal fractional nPLL allows support for a wide range of reference clock frequencies
- Supports IEEE 802.15.2 external coexistence interface to optimize bandwidth utilization with other colocated wireless technologies such as GPS, WiMAX, or UWB
- Supports standard SDIO v3.0 (208 MHz, 4-bit and 1-bit), and gSPI (48 MHz) host interfaces
- Alternative host interface supports HSIC v1.0 (short-distance USB device)
- Integrated ARM® Cortex-M3™ processor and on-chip memory for complete WLAN subsystem functionality, minimizing the need to wake up the applications processor for standard WLAN functions. (This allows for further minimization of power consumption, while maintaining the ability to field upgrade with future features. On-chip memory includes 576 KB SRAM and 640 KB ROM.)
- OneDriver™ software architecture for easy migration from existing embedded WLAN and Bluetooth devices as well as future devices

FEATURES**Bluetooth and FM Key Features**

- Complies with Bluetooth Core Specification Version 4.0 + HS with provisions for supporting future specifications
- Bluetooth Class 1 or Class 2 transmitter operation
- Supports extended Synchronous Connections (eSCO) for enhanced voice quality by allowing for retransmission of dropped packets
- Adaptive Frequency Hopping (AFH) for reducing radio frequency interference
- Interface support — Host Controller Interface (HCI) using a high-speed UART interface and PCM for audio data
- FM unit supports HCI for communication
- Low power consumption improves battery life of handheld devices
- FM receiver: 65 MHz to 108 MHz FM bands; supports the European Radio Data Systems (RDS) and the North American Radio Broadcast Data System (RBDS) standards
- Supports multiple simultaneous Advanced Audio Distribution Profiles (A2DP) for stereo sound
- Automatic frequency detection for standard crystal and TCXO values

General Features

- Supports battery voltage range from 2.3V to 4.8V supplies with internal switching regulator
- Programmable dynamic power management
- 3072-bit OTP for storing board parameters
- 16 general-purpose I/Os (GPIOs)
- Package options:
 - FCFBGA (7.0 mm × 9.0 mm, 0.4 mm pitch)

Security

- WPA™ and WPA2™ (Personal) support for powerful encryption and authentication
- AES and TKIP in hardware for faster data encryption and IEEE 802.11i compatibility
- Reference WLAN subsystem provides Cisco® Compatible Extensions (CCX, CCX 2.0, CCX 3.0, CCX 4.0, CCX 5.0)
- Reference WLAN subsystem provides Wi-Fi Protected Setup (WPS)
- Worldwide regulatory support: Global products supported with worldwide homologated design

Revision History

<i>Revision</i>	<i>Date</i>	<i>Change Description</i>
002-14917 *D	09/22/16	Parts in this datasheet are not recommended for new designs.
43241-DS103-R	5/19/12	<p>Updated:</p> <ul style="list-style-type: none"> • Bluetooth and FM Key Features on Cover • SDIO v3.0 maximum clock rate • Figure 3: “Mobile Phone Block System Diagram,” on page 22 • Figure 4: “Typical Power Topology,” on page 24 • “Power Supply Topology” on page 23 • Table 2: “Crystal Oscillator and External Clock – Requirements and Performance,” on page 30 • “Features” on page 33 • Table 4: “Power Control Pin Description,” on page 39 • “BBC Power Management” on page 40 • “RDS/RBDS” on page 65 • Figure 32: “WLAN Bootup Sequence,” on page 77 • Table 28: “Bluetooth Receiver RF Specifications,” on page 111 • Table 32: “FM Receiver Specifications,” on page 116 • Table 34: “WLAN 2.4 GHz Receiver Performance Specifications,” on page 125 • Table 35: “WLAN 2.4 GHz Transmitter Performance Specifications,” on page 129 • Table 36: “WLAN 5 GHz Receiver Performance Specifications,” on page 131 • Table 37: “WLAN 5 GHz Transmitter Performance Specifications,” on page 135 • Table 39: “Core Buck Switching Regulator (CBUCK) Specifications,” on page 137 • Table 41: “CLDO Specifications,” on page 140 • Table 42: “LNLDO2 Specifications,” on page 141 • Table 43: “LNLDO1 Specifications,” on page 142 • Table 44: “BCM43241 WLAN Current Consumption 2.4 GHz,” on page 143 • Table 45: “BCM43241 WLAN Current Consumption 5 GHz,” on page 144 • Table 46: “BT Current Consumption,” on page 146

Not Recommended for New Designs

Revision	Date	Change Description
		<ul style="list-style-type: none"> • Table 47: “BLE Current Consumption,” on page 147 • Table 48: “FM Current Consumption,” on page 147 • Figure 51: “WLAN = ON, Bluetooth = ON,” on page 162 • Figure 52: “WLAN = OFF, Bluetooth = OFF,” on page 162 • Figure 53: “WLAN = ON, Bluetooth = OFF,” on page 163 • Figure 54: “WLAN = OFF, Bluetooth = ON,” on page 163 • “Preliminary Package Thermal Characteristics” on page 164 <p>Removed:</p> <ul style="list-style-type: none"> • Specific ROM and RAM values for Bluetooth operation
43241-DS102-R	01/26/12	<p>Updated:</p> <ul style="list-style-type: none"> • “UART Interface” on page 64 • Table 18: “FCFBGA and WLCSP Signal Descriptions,” on page 97 • Table 28: “Recommended Operating Conditions and DC Characteristics,” on page 116 • Table 35: “WLAN 2.4 GHz Receiver Performance Specifications,” on page 131 • Table 36: “WLAN 2.4 GHz Transmitter Performance Specifications,” on page 135 • Table 37: “WLAN 5 GHz Receiver Performance Specifications,” on page 136 • Table 38: “WLAN 5 GHz Transmitter Performance Specifications,” on page 140
43241-DS101-R	11/17/11	<p>Updated:</p> <ul style="list-style-type: none"> • “Ordering Information” on page 188.
43241-DS100-R	09/22/11	Initial release

Table of Contents

- About This Document**..... 16
 - Purpose and Audience 16
 - Acronyms and Abbreviations 16
 - Document Conventions 16
- Technical Support**..... 16
- Section 1: Overview** **17**
 - Overview 17
 - Features 19
 - Standards Compliance..... 20
 - Mobile Device Usage Model 21
- Section 2: Power Supplies and Power Management**..... **23**
 - Power Supply Topology..... 23
 - BCM43241 PMU Features..... 23
 - WLAN Power Management..... 25
 - PMU Sequencing 25
 - Power-off Shutdown 26
 - Power-Up/Power-Down/Reset Circuits..... 27
- Section 3: Frequency References** **28**
 - Crystal Interface and Clock Generation 28
 - TCXO 29
 - Frequency Selection 31
 - External 32.768 kHz Low-Power Oscillator 32
- Section 4: Bluetooth + FM Subsystem Overview**..... **33**
 - Features 33
 - Bluetooth Radio**..... 35
 - Transmit 35
 - Digital Modulator..... 35
 - Digital Demodulator and Bit Synchronizer..... 35
 - Power Amplifier 35
 - Receiver 36
 - Digital Demodulator and Bit Synchronizer..... 36
 - Receiver Signal Strength Indicator 36
 - Local Oscillator Generation..... 36

Not Recommended for New Designs

Calibration.....36

Section 5: Bluetooth Baseband Core..... 37

Bluetooth 4.0 Features.....37

Bluetooth Low Energy37

Link Control Layer38

Test Mode Support.....38

Bluetooth Power Management Unit39

 RF Power Management39

 Host Controller Power Management.....39

 BBC Power Management40

 FM Power Management41

 Wideband Speech41

 Packet Loss Concealment41

 Audio Rate-Matching Algorithms42

 Codec Encoding.....42

 Multiple Simultaneous A2DP Audio Stream42

 FM Over Bluetooth43

 Burst Buffer Operation43

Adaptive Frequency Hopping.....43

Advanced Bluetooth/WLAN Coexistence43

Fast Connection (Interlaced Page and Inquiry Scans)44

Section 6: Music and Audio 45

MP3 Encoder.....45

MP3 Decoder45

AAC/AAC+ Decoder45

Section 7: Microprocessor and Memory Unit for Bluetooth..... 46

RAM, ROM, and Patch Memory.....46

Reset46

Section 8: Bluetooth Peripheral Transport Unit 47

PCM Interface47

 Slot Mapping.....47

 Frame Synchronization47

 Data Formatting.....47

 Wideband Speech Support48

 Multiplexed Bluetooth and FM Over PCM.....48

 Burst PCM Mode.....49

Not Recommended for New Designs

PCM Interface Timing	50
Short Frame Sync, Master Mode	50
Short Frame Sync, Slave Mode	51
Long Frame Sync, Master Mode	52
Long Frame Sync, Slave Mode	53
Short Frame Sync, Burst Mode	54
Long Frame Sync, Burst Mode	55
UART Interface	56
I²S Interface	58
I ² S Timing	58
Section 9: FM Receiver Subsystem	61
FM Radio	61
Digital FM Audio Interfaces	61
FM Over Bluetooth	61
eSCO	61
Wideband Speech Link	62
A2DP	62
Autotune and Search Algorithms	62
Audio Features	62
On-Chip MP3 Encoding	65
RDS/RBDS	65
Section 10: WLAN Global Functions	66
WLAN CPU and Memory Subsystem	66
One-Time Programmable Memory	66
GPIO Interface	67
External Coexistence Interface	67
UART Interface	67
JTAG Interface	67
Section 11: WLAN Host Interfaces	68
SDIO v3.0	68
SDIO Pin Descriptions	68
Generic SPI Mode	70
SPI Protocol	71
Command Structure	72
Write	72

Not Recommended for New Designs

Write/Read	72
Read	72
Status	73
gSPI Host-Device Handshake	75
Bootup Sequence	75
HSIC Interface	78
Section 12: Wireless LAN MAC and PHY	79
MAC Features	79
MAC Description	79
PSM	80
WEP	81
TXE	81
RXE	81
IFS	82
TSF	82
NAV	82
MAC-PHY Interface	82
WLAN PHY Description	83
PHY Features	83
Section 13: WLAN Radio Subsystem	86
Receiver Path	86
Transmit Path	86
Calibration	86
Section 14: Pinout and Signal Descriptions	88
Signal Assignments	88
Signal Descriptions	90
WLAN GPIO Signals and Strapping Options	98
Multiplexed Bluetooth GPIO Signals	101
I/O States	103
Section 15: DC Characteristics	106
Absolute Maximum Ratings	106
Environmental Ratings	107
Electrostatic Discharge Specifications	107
Recommended Operating Conditions and DC Characteristics	108

Not Recommended for New Designs

Section 16: Bluetooth RF Specifications	110
Section 17: FM Receiver Specifications	116
Section 18: WLAN RF Specifications.....	123
Introduction.....	123
2.4 GHz Band General RF Specifications	124
WLAN 2.4 GHz Receiver Performance Specifications.....	125
WLAN 2.4 GHz Transmitter Performance Specifications.....	129
WLAN 5 GHz Receiver Performance Specifications	131
WLAN 5 GHz Transmitter Performance Specifications.....	135
General Spurious Emissions Specifications.....	136
Section 19: Internal Regulator Electrical Specifications	137
Core Buck Switching Regulator	137
3.3V LDO (LDO3P3).....	139
CLDO	140
LNLDO2	141
LNLDO1	142
Section 20: System Current Consumption.....	143
WLAN Current Consumption.....	143
Bluetooth and FM Current Consumption	146
Section 21: Interface Timing and AC Characteristics	148
SDIO/gSPI Timing.....	148
SDIO Default Mode Timing	148
SDIO High-Speed Mode Timing.....	150
SDIO Bus Timing Specifications in SDR Modes.....	151
Clock Timing.....	151
Card Input Timing	152
Card Output Timing	153
SDIO Bus Timing Specifications in DDR50 Mode	156
Data Timing.....	157
gSPI Signal Timing	158
HSIC Interface Specifications.....	159
JTAG Timing	160
Section 22: Power-Up Sequence and Timing.....	161
Sequencing of Reset and Regulator Control Signals.....	161

Description of Control Signals.....	161
Control Signal Timing Diagrams	162
Section 23: Package Information	164
Preliminary Package Thermal Characteristics	164
Junction Temperature Estimation and Ψ_{JT} Versus Θ_{JC}	164
Environmental Characteristics	164
Section 24: Mechanical Information	165
Section 25: Ordering Information	166
Section 26: Pin List	167

Not Recommended for New Designs

List of Figures

Figure 1: Functional Block Diagram	2
Figure 2: BCM43241 Block Diagram	18
Figure 3: Mobile Phone Block System Diagram.....	22
Figure 4: Typical Power Topology.....	24
Figure 5: Recommended Oscillator Configuration	28
Figure 6: Recommended Circuit to Use with an External Dedicated TCXO.....	29
Figure 7: Recommended Circuit to Use with an External Shared TCXO.....	29
Figure 8: Start-up Signaling Sequence.....	40
Figure 9: CVSD Decoder Output Waveform Without PLC	42
Figure 10: CVSD Decoder Output Waveform After Applying PLC	42
Figure 11: Functional Multiplex Data Diagram.....	48
Figure 12: PCM Timing Diagram (Short Frame Sync, Master Mode).....	50
Figure 13: PCM Timing Diagram (Short Frame Sync, Slave Mode).....	51
Figure 14: PCM Timing Diagram (Long Frame Sync, Master Mode).....	52
Figure 15: PCM Timing Diagram (Long Frame Sync, Slave Mode).....	53
Figure 16: PCM Burst Mode Timing (Receive Only, Short Frame Sync)	54
Figure 17: PCM Burst Mode Timing (Receive Only, Long Frame Sync)	55
Figure 18: UART Timing	57
Figure 19: I ² S Transmitter Timing.....	60
Figure 20: I ² S Receiver Timing.....	60
Figure 21: Example Blend/Switch Usage	63
Figure 22: Example Blend/Switch Separation	63
Figure 23: Example Soft Mute Characteristic	64
Figure 24: Signal Connections to SDIO Host (SD 4-Bit Mode)	69
Figure 25: Signal Connections to SDIO Host (SD 1-Bit Mode)	69
Figure 26: Signal Connections to SDIO Host (gSPI Mode)	70
Figure 27: gSPI Write Protocol	71
Figure 28: gSPI Read Protocol	71
Figure 29: gSPI Command Structure.....	72
Figure 30: gSPI Signal Timing Without Status.....	73
Figure 31: gSPI Signal Timing with Status (Response Delay = 0)	74
Figure 32: WLAN Bootup Sequence	77
Figure 33: HSIC Device Block Diagram.....	78
Figure 34: WLAN MAC Architecture	80
Figure 35: WLAN PHY Block Diagram	84

Figure 36: STBC Receive Block Diagram	85
Figure 37: Radio Functional Block Diagram.....	87
Figure 38: 208-Ball FCFBGA Ball Map (Top View).....	89
Figure 39: RF Port Location for Bluetooth Testing	110
Figure 40: Port Locations.....	123
Figure 41: SDIO Bus Timing (Default Mode).....	148
Figure 42: SDIO Bus Timing (High-Speed Mode)	150
Figure 43: SDIO Clock Timing (SDR Modes).....	151
Figure 44: SDIO Bus Input Timing (SDR Modes)	152
Figure 45: SDIO Bus Output Timing (SDR Modes up to 100 MHz).....	153
Figure 46: SDIO Bus Output Timing (SDR Modes 100 MHz to 208 MHz)	154
Figure 47: Δt_{OP} Consideration for Variable Data Window (SDR 104 Mode)	155
Figure 48: SDIO Clock Timing (DDR50 Mode).....	156
Figure 49: SDIO Data Timing (DDR50 Mode).....	157
Figure 50: gSPI Timing	158
Figure 51: WLAN = ON, Bluetooth = ON.....	162
Figure 52: WLAN = OFF, Bluetooth = OFF.....	162
Figure 53: WLAN = ON, Bluetooth = OFF.....	163
Figure 54: WLAN = OFF, Bluetooth = ON.....	163
Figure 55: 208-Ball FCFBGA Package Mechanical Information	165

List of Tables

Table 1: Power-Up/Power-Down/Reset Control Signals	27
Table 2: Crystal Oscillator and External Clock – Requirements and Performance	30
Table 3: External 32.768 kHz Sleep Clock Specifications	32
Table 4: Power Control Pin Description	39
Table 5: PCM Interface Timing Specifications (Short Frame Sync, Master Mode)	50
Table 6: PCM Interface Timing Specifications (Short Frame Sync, Slave Mode)	51
Table 7: PCM Interface Timing Specifications (Long Frame Sync, Master Mode)	52
Table 8: PCM Interface Timing Specifications (Long Frame Sync, Slave Mode)	53
Table 9: PCM Burst Mode (Receive Only, Short Frame Sync)	54
Table 10: PCM Burst Mode (Receive Only, Long Frame Sync)	55
Table 11: Example of Common Baud Rates.....	56
Table 12: UART Timing Specifications	57
Table 13: Timing for I ² S Transmitters and Receivers.....	59
Table 14: SDIO Pin Description.....	68
Table 15: gSPI Status Field Details.....	74
Table 16: gSPI Registers.....	75
Table 17: FCBGA Signal Descriptions.....	90
Table 18: WLAN GPIO Functions and Strapping Options (Advance Information)	98
Table 19: OTP Select.....	99
Table 20: WLAN GPIO Functions and Strapping Options (Advance Information)	100
Table 21: GPIO Multiplexing Matrix	101
Table 22: Multiplexed GPIO Signals.....	102
Table 23: I/O States	103
Table 24: Absolute Maximum Ratings.....	106
Table 25: Environmental Ratings.....	107
Table 26: ESD Specifications.....	107
Table 27: Recommended Operating Conditions and DC Characteristics	108
Table 28: Bluetooth Receiver RF Specifications	111
Table 29: Bluetooth Transmitter RF Specifications	114
Table 30: Local Oscillator Performance.....	115
Table 31: BLE RF Specifications	115
Table 32: FM Receiver Specifications	116
Table 33: 2.4 GHz Band General RF Specifications.....	124
Table 34: WLAN 2.4 GHz Receiver Performance Specifications	125
Table 35: WLAN 2.4 GHz Transmitter Performance Specifications.....	129

Table 36: WLAN 5 GHz Receiver Performance Specifications	131
Table 37: WLAN 5 GHz Transmitter Performance Specifications	135
Table 38: General Spurious Emissions Specifications	136
Table 39: Core Buck Switching Regulator (CLOCK) Specifications	137
Table 40: LDO3P3 Specifications	139
Table 41: CLDO Specifications	140
Table 42: LNLDO2 Specifications	141
Table 43: LNLDO1 Specifications	142
Table 44: BCM43241 WLAN Current Consumption 2.4 GHz	143
Table 45: BCM43241 WLAN Current Consumption 5 GHz	144
Table 46: BT Current Consumption	146
Table 47: BLE Current Consumption	147
Table 48: FM Current Consumption	147
Table 49: SDIO Bus Timing Parameters (Default Mode).....	148
Table 50: SDIO Bus Timing Parameters (High-Speed Mode).....	150
Table 51: SDIO Bus Clock Timing Parameters (SDR Modes).....	151
Table 52: SDIO Bus Input Timing Parameters (SDR Modes).....	152
Table 53: SDIO Bus Output Timing Parameters (SDR Modes up to 100 MHz)	153
Table 54: SDIO Bus Output Timing Parameters (SDR Modes 100 MHz to 208 MHz)	154
Table 55: SDIO Bus Clock Timing Parameters (DDR50 Mode).....	156
Table 56: SDIO Bus Timing Parameters (DDR50 Mode)	157
Table 57: gSPI Timing Parameters	158
Table 58: HSIC Timing Parameters	159
Table 59: JTAG Timing Characteristics.....	160
Table 60: Package JEDEC Thermal Characteristics	164
Table 61: 208-Pin FCBGA Package Pin List By Pin Number	167
Table 62: 208-Pin FCBGA Package Pin List By Pin Name	170

About This Document

Purpose and Audience

This data sheet provides details about the functional, operational, and electrical characteristics of the Broadcom BCM43241. It is intended for hardware design, application, and OEM engineers.

Acronyms and Abbreviations

In most cases, acronyms and abbreviations are defined on first use.

For a comprehensive list of acronyms and other terms used in Broadcom documents, go to: <http://www.broadcom.com/press/glossary.php>.

Document Conventions

The following conventions may be used in this document:

<i>Convention</i>	<i>Description</i>
Bold	User input and actions: for example, type exit , click OK , press Alt+C
Monospace	Code: #include <iostream> HTML: <td rowspan = 3> Command line commands and parameters: w1 [-1] <command>
< >	Placeholders for <i>required</i> elements: enter your <username> or w1 <command>
[]	Indicates <i>optional</i> command-line parameters: w1 [-1] Indicates bit and byte ranges (inclusive): [0:3] or [7:0]

Technical Support

Broadcom provides customer access to a wide range of information, including technical documentation, schematic diagrams, product bill of materials, PCB layout information, and software updates through its customer support portal (<https://support.broadcom.com>). For a CSP account, contact your Sales or Engineering support representative.

In addition, Broadcom provides other product support through its Downloads & Support site (<http://www.broadcom.com/support/>).

Section 1: Overview

Overview

The Broadcom BCM43241 single-chip device provides the highest level of integration for a mobile or handheld wireless system, with integrated IEEE 802.11 a/b/g/n (MAC/baseband/radio), Bluetooth 4.0 + EDR (enhanced data rate), and FM receiver. It provides a small form-factor solution with minimal external components to drive down cost for mass volumes and allows for handheld device flexibility in size, form, and function.

Comprehensive power management circuitry and software ensure the system can meet the needs of highly mobile devices that require minimal power consumption and reliable operation.

[Figure 2](#) shows the interconnect of all the major physical blocks in the BCM43241 and their associated external interfaces, which are described in greater detail in the following sections.

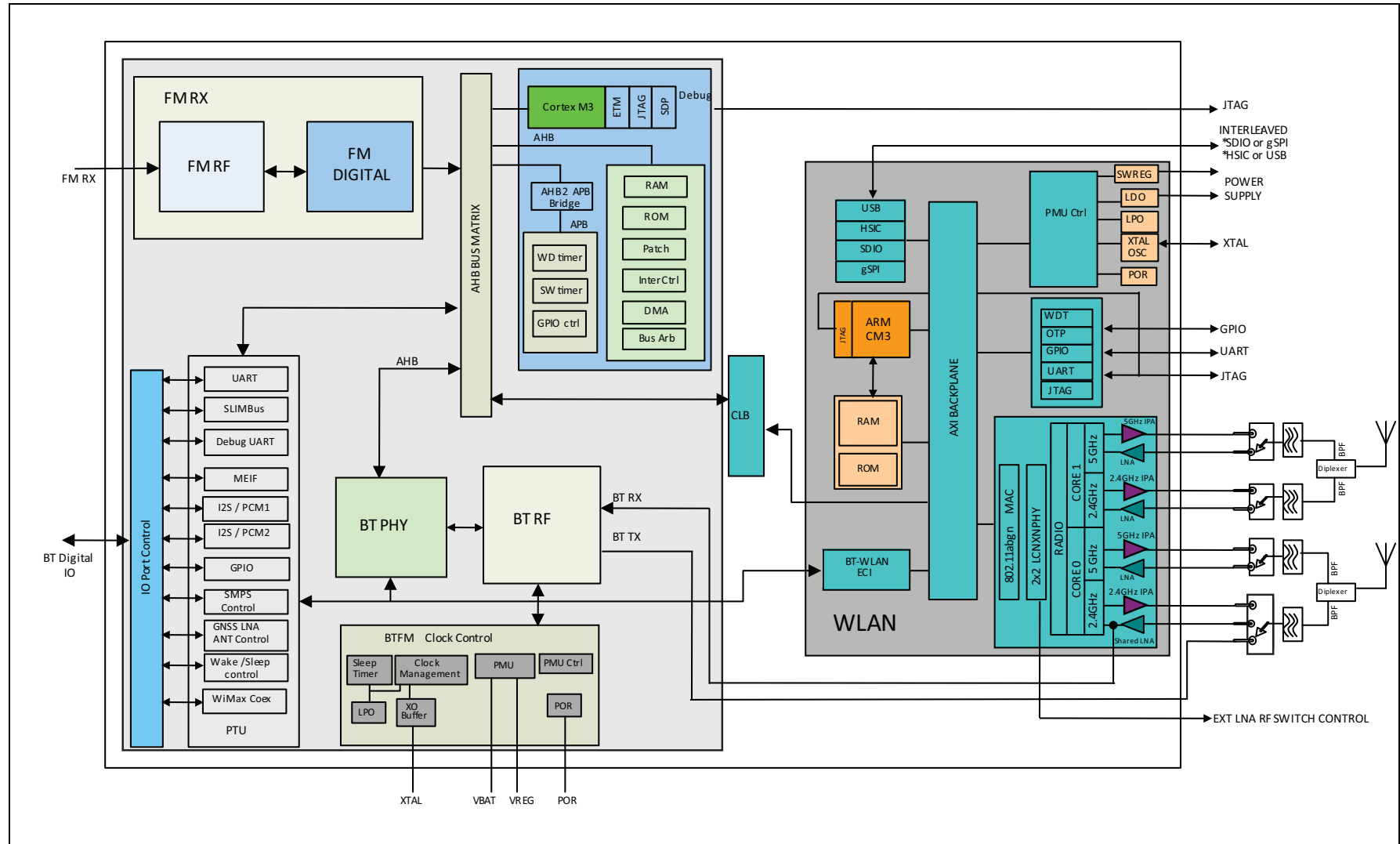

Figure 2: BCM43241 Block Diagram

Not Recommended for New Designs

Features

The BCM43241 supports the following features:

- IEEE 802.11a/b/g/n dual-band radio— virtual simultaneous dual-band operation
- Bluetooth v4.0 + EDR with integrated Class 1 PA
- Concurrent Bluetooth, FM (RX) RDS/RBDS, and WLAN operation
- On-chip WLAN driver execution capable of supporting IEEE 802.11 functionality
- Single- and dual-antenna support
 - Single antenna with shared LNA
 - Simultaneous BT/WLAN receive with single antenna
- WLAN host interface options:
 - SDIO v3.0 (1-bit/4-bit)— up to 208 MHz clock rate
 - gSPI— up to 48 MHz clock rate
 - HSIC (USB device interface for short distance on-board applications)
- BT host digital interface (can be used concurrently with above interfaces):
 - UART (up to 4 Mbps)
- ECI— enhanced coexistence support, ability to coordinate BT SCO transmissions around WLAN receives
- I²S/PCM for FM/BT audio, HCI for FM block control
- HCI high-speed UART (H4, H4+, H5) transport support
- Wideband speech support (16 bits linear data, MSB first, left justified at 4K samples/s for transparent air coding, both through I²S and PCM interface)
- Bluetooth SmartAudio technology improves voice and music quality to headsets
- Bluetooth low-power inquiry and page scan
- Bluetooth Low Energy (BLE) support
- Bluetooth Packet Loss Concealment (PLC)
- Bluetooth wideband speech (WBS)
- FM advanced internal antenna support
- FM auto search/tuning functions
- FM multiple audio routing options: I²S, PCM, eSCO, A2DP
- FM mono-stereo blend and switch, and soft mute support
- FM audio pause detect support
- Audio rate-matching algorithms
- Multiple simultaneous A2DP audio stream
- FM over Bluetooth operation and on-chip stereo headset emulation (SBC, MP3, and AAC+)
- MP3, AAC+ on-chip decoder for low power music playback

Standards Compliance

The BCM43241 supports the following standards:

- Bluetooth 2.1 + EDR
- Bluetooth 3.0 + HS
- Bluetooth 4.0 (Bluetooth Low Energy)
- 65 MHz to 108 MHz FM bands (US, Europe, and Japan)
- IEEE 802.11n — Handheld Device Class (Section 11)
- IEEE 802.11a
- IEEE 802.11b
- IEEE 802.11g
- IEEE 802.11d
- IEEE 802.11h
- IEEE 802.11i

The BCM43241 supports the following future drafts/standards:

- IEEE 802.11r — Fast Roaming (between APs)
- IEEE 802.11k — Resource Management
- IEEE 802.11w — Secure Management Frames
- IEEE 802.11 Extensions:
 - IEEE 802.11e QoS Enhancements (as per the WMM® specification is already supported)
 - IEEE 802.11h 5 GHz Extensions
 - IEEE 802.11i MAC Enhancements
 - IEEE 802.11r Fast Roaming Support
 - IEEE 802.11k Radio Resource Measurement
- Security:
 - WEP
 - WPA™ Personal
 - WPA2™ Personal
 - WMM
 - WMM-PS (U-APSD)
 - WMM-SA
 - AES (Hardware Accelerator)
 - TKIP (HW Accelerator)
 - CKIP (SW Support)
- Proprietary Protocols:
 - CCXv2
 - CCXv3
 - CCXv4

- CCXv5
- WFAEC
- IEEE 802.15.2 Coexistence Compliance — on silicon solution compliant with IEEE 3 wire requirements

Mobile Device Usage Model

The BCM43241 incorporates a number of unique features to simplify integration into mobile phone platforms. Its flexible PCM and UART interfaces enable it to transparently connect with the existing circuits. In addition, the TCXO and LPO inputs allow the use of existing handset features to further minimize the size, power, and cost of the complete system.

- The PCM interface provides multiple modes of operation to support both master and slave as well as hybrid, interfacing to single or multiple external codec devices.
- The UART interface supports hardware flow control with tight integration to power control sideband signaling to support the lowest power operation.
- The TCXO interface accommodates any of the typical reference frequencies used by cell phones.
- FM digital interfaces can use either I²S or PCM.
- The highly linear design of the radio transceiver ensures that the device has the lowest spurious emissions output regardless of the state of operation. It has been fully characterized in the global cellular bands.
- The transceiver design has excellent blocking (eliminating desensitization of the Bluetooth receiver) and intermodulation performance (distortion of the transmitted signal caused by the mixing of the cellular and Bluetooth transmissions) in the presence of any cellular transmission (GSM[®], GPRS, CDMA, WCDMA, or iDEN). Minimal external filtering is required for integration inside the handset.

Not Recommended for New Designs

The BCM43241 is designed to provide direct interface with new and existing handset designs as shown in Figure 3.

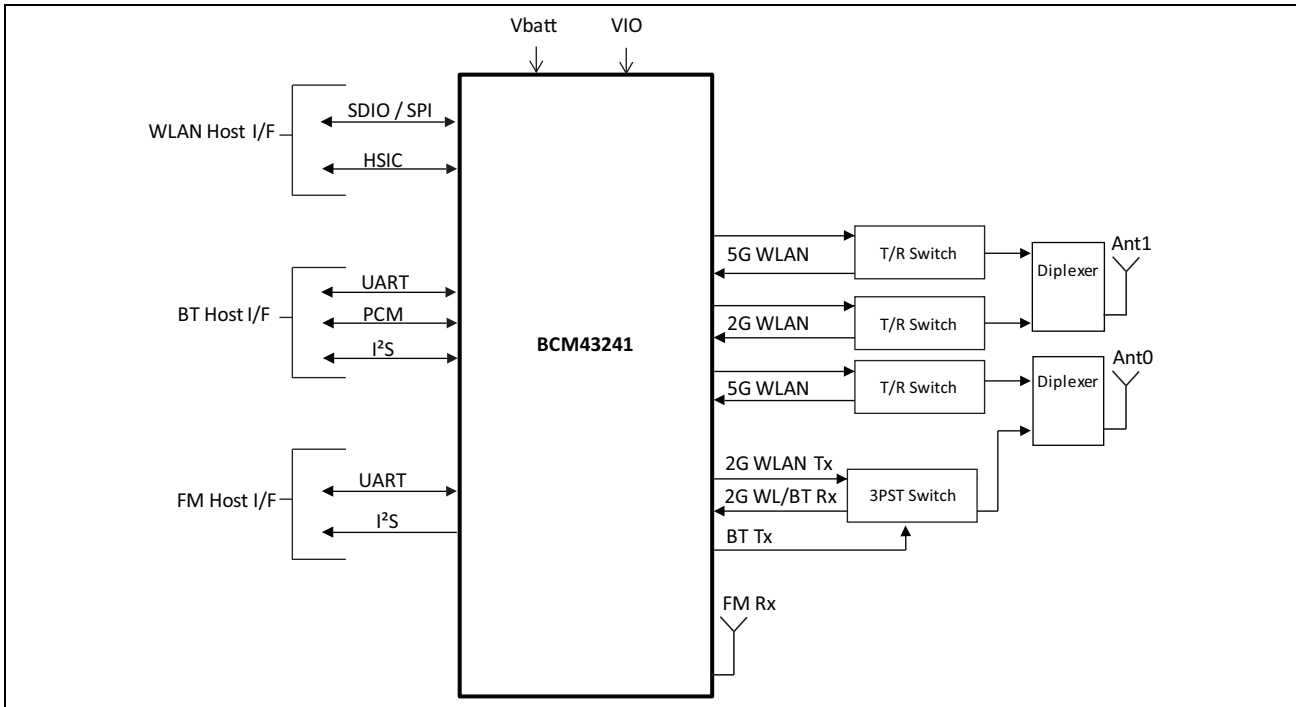

Figure 3: Mobile Phone Block System Diagram

Not Recommended for New Designs

Section 2: Power Supplies and Power Management

Power Supply Topology

One Buck regulator, multiple LDO regulators, and a Power Management Unit (PMU) are integrated into the BCM43241. All regulators are programmable via the PMU. These blocks simplify power supply design for Bluetooth, WLAN, and FM functions in embedded designs.

A single VBAT (2.3V to 4.8V) and VIO supply (1.8V to 3.3V) can be used, with all additional voltages being provided by the regulators in the BCM43241.

Two control signals, BT_REG_ON and WL_REG_ON, are used to power-up the regulators and take the respective section out of reset. The CBUCK, CLDO, and LNLDOs power up when any of the reset signals are deasserted. All regulators are powered down only when both BT_REG_ON and WL_REG_ON are deasserted. The CLDO and LNLDOs may be turned off/on based on the dynamic demands of the digital baseband.

The BCM43241 allows for an extremely low power-consumption mode by completely shutting down the CBUCK, CLDO, and LNDLO regulators. When in this state, LPLDO1 and LPLDO2 (which are low-power linear regulators that are supplied by the system VIO supply) provide the BCM43241 with all the voltages it requires, further reducing leakage currents.

BCM43241 PMU Features

- VBAT to 1.35V_{out} (600 mA maximum) Core-Buck (CBUCK) switching regulator
- VBAT to 3.3V_{out} (125 mA maximum) LDO3P3
- 1.35V to 1.2V_{out} (150 mA and 325 mA maximum) LNLDOs
- 1.35V to 1.2V_{out} (300 mA maximum) CLDO
- Additional internal LDOs (not externally accessible)

Figure 4 shows the regulators and a typical power topology.

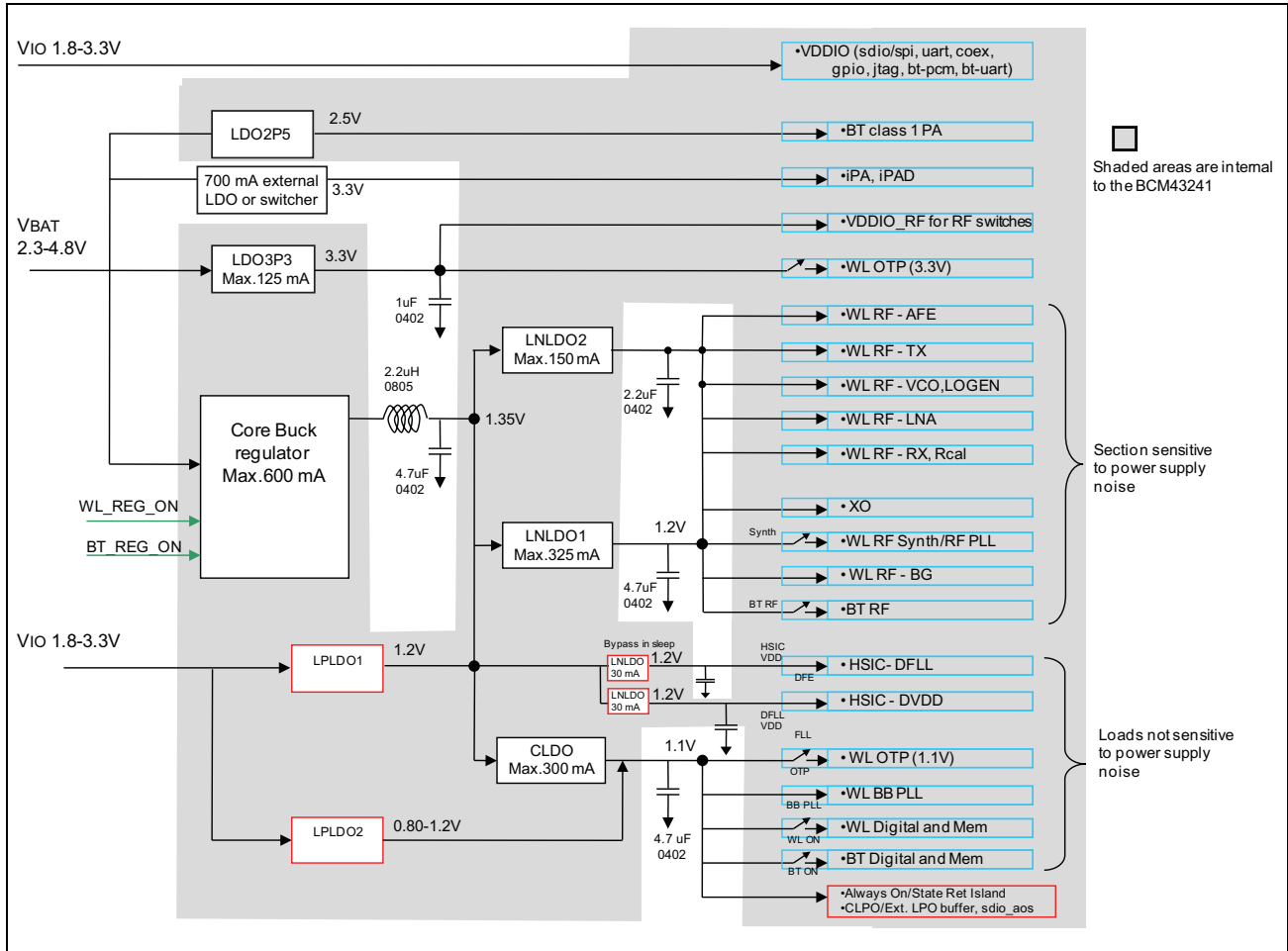

Figure 4: Typical Power Topology

Not Recommended for New Designs

WLAN Power Management

The BCM43241 has been designed with the stringent power consumption requirements of mobile devices in mind. All areas of the chip design are optimized to minimize power consumption. Silicon processes and cell libraries were chosen to reduce leakage current and supply voltages. Additionally, the BCM43241 integrated RAM is a high Vt memory with dynamic clock control. The dominant supply current consumed by the RAM is leakage current only. Additionally, the BCM43241 includes an advanced WLAN power management unit (PMU) sequencer. The PMU sequencer provides significant power savings by putting the BCM43241 into various power management states appropriate to the current environment and activities that are being performed. The power management unit enables and disables internal regulators, switches, and other blocks based on a computation of the required resources and a table that describes the relationship between resources and the time needed to enable and disable them. Power-up sequences are fully programmable. Configurable, free-running counters (running at 32.768 kHz LPO clock) in the PMU sequencer are used to turn on/turn off individual regulators and power switches. Clock speeds are dynamically changed (or gated altogether) for the current mode. Slower clock speeds are used wherever possible.

The BCM43241 WLAN power states are described as follows:

- Active mode — All WLAN blocks in the BCM43241 are powered up and fully functional with active carrier sensing and frame transmission and receiving. All required regulators are enabled and put in the most efficient mode based on the load current. Clock speeds are dynamically adjusted by the PMU sequencer.
- Doze mode — The radio, analog domains, and most of the linear regulators are powered down. The rest of the BCM43241 remains powered up in an IDLE state. All main clocks (PLL, crystal oscillator or TCXO) are shut down to reduce active power to the minimum. The 32.768 kHz LPO clock is available only for the PMU sequencer. This condition is necessary to allow the PMU sequencer to wake up the chip and transition to Active mode. In Doze mode, the primary power consumed is due to leakage current.
- Deep-sleep mode — Most of the chip including both analog and digital domains and most of the regulators are powered off. Logic states in the digital core are saved and preserved into a retention memory in the always-ON domain before the digital core is powered off. Upon a wake-up event triggered by the PMU timers, an external interrupt or a host resume through the HSIC or SDIO bus, logic states in the digital core are restored to their pre-deep-sleep settings to avoid lengthy HW reinitialization.
- Power-down mode — The BCM43241 is effectively powered off by shutting down all internal regulators. The chip is brought out of this mode by external logic, reenabling the internal regulators.

PMU Sequencing

The PMU sequencer is responsible for minimizing system power consumption. It enables and disables various system resources based on a computation of the required resources and a table that describes the relationship between resources and the time needed to enable and disable them.

Resource requests may come from several sources: clock requests from cores, the minimum resources defined in the ResourceMin register, and the resources requested by any active resource request timers. The PMU sequencer maps clock requests into a set of resources required to produce the requested clocks.

Each resource is in one of four states: enabled, disabled, transition_on, and transition_off and has a timer that contains 0 when the resource is enabled or disabled and a non-zero value in the transition states. The timer is loaded with the time_on or time_off value of the resource when the PMU determines that the resource must be enabled or disabled. That timer decrements on each 32.768 kHz PMU clock. When it reaches 0, the state changes from transition_off to disabled or transition_on to enabled. If the time_on value is 0, the resource can go immediately from disabled to enabled. Similarly, a time_off value of 0 indicates that the resource can go immediately from enabled to disabled. The terms enable sequence and disable sequence refer to either the immediate transition or the timer load-decrement sequence.

During each clock cycle, the PMU sequencer performs the following actions:

- Computes the required resource set based on requests and the resource dependency table.
- Decrements all timers whose values are non zero. If a timer reaches 0, the PMU clears the ResourcePending bit for the resource and inverts the ResourceState bit.
- Compares the request with the current resource status and determines which resources must be enabled or disabled.
- Initiates a disable sequence for each resource that is enabled, no longer being requested, and has no powered-up dependents.
- Initiates an enable sequence for each resource that is disabled, is being requested, and has all of its dependencies enabled.

Power-off Shutdown

The BCM43241 provides a low-power shutdown feature that allows the device to be turned off while the host, and any other devices in the system, remain operational. When the BCM43241 is not needed in the system, VDDIO_RF and VDDC are shut down while VDDIO remains powered. This allows the BCM43241 to be effectively off while keeping the I/O pins powered so that they do not draw extra current from any other devices connected to the I/O.

During a low-power shutdown state, provided VDDIO remains applied to the BCM43241, all outputs are tristated, and most input signals are disabled. Input voltages must remain within the limits defined for normal operation. This is done to prevent current paths or create loading on any digital signals in the system, and enables the BCM43241 to be fully integrated in an embedded device and take full advantage of the lowest power-savings modes.

Two signals on the BCM43241, the frequency reference input (WRF_XTAL_CAB_OP) and the LPO_IN input, are designed to be high-impedance inputs that do not load down the driving signal even if the chip does not have VDDIO power applied to it.

When the BCM43241 is powered on from this state, it is the same as a normal power-up and the device does not retain any information about its state from before it was powered down.

Power-Up/Power-Down/Reset Circuits

The BCM43241 has two signals (see [Table 1](#)) that enable or disable the Bluetooth and WLAN circuits and the internal regulator blocks, allowing the host to control power consumption. For timing diagrams of these signals and the required power-up sequences, see [Section 22: “Power-Up Sequence and Timing,”](#) on page 161.

Table 1: Power-Up/Power-Down/Reset Control Signals

Signal	Description
WL_REG_ON	This signal is used by the PMU (with BT_REG_ON) to power up the WLAN section. It is also OR-gated with the BT_REG_ON input to control the internal BCM43241 regulators. When this pin is high, the regulators are enabled and the WLAN section is out of reset. When this pin is low, the WLAN section is in reset. If BT_REG_ON and WL_REG_ON are both low, the regulators are disabled. This pin has an internal 200 kΩ pull-down resistor that is enabled by default. It can be disabled through programming.
BT_REG_ON	This signal is used by the PMU (with WL_REG_ON) to decide whether or not to power down the internal BCM43241 regulators. If BT_REG_ON and WL_REG_ON are low, the regulators will be disabled. This pin has an internal 200 kΩ pull-down resistor that is enabled by default. It can be disabled through programming.

Section 3: Frequency References

An external crystal is used for generating all radio frequencies and normal operation clocking. As an alternative, an external frequency reference driven by a temperature-compensated crystal oscillator (TCXO) signal may be used. In addition, a low-power oscillator (LPO) is provided for lower power mode timing.



Note: The crystal and TCXO implementations have different power supplies (WRF_XTAL_VDD1P2 for crystal, WRF_TCXO_VDD for TCXO).

Crystal Interface and Clock Generation

The BCM43241 can use an external crystal to provide a frequency reference. The recommended configuration for the crystal oscillator including all external components is shown in [Figure 5](#). Consult the reference schematics for the latest configuration.

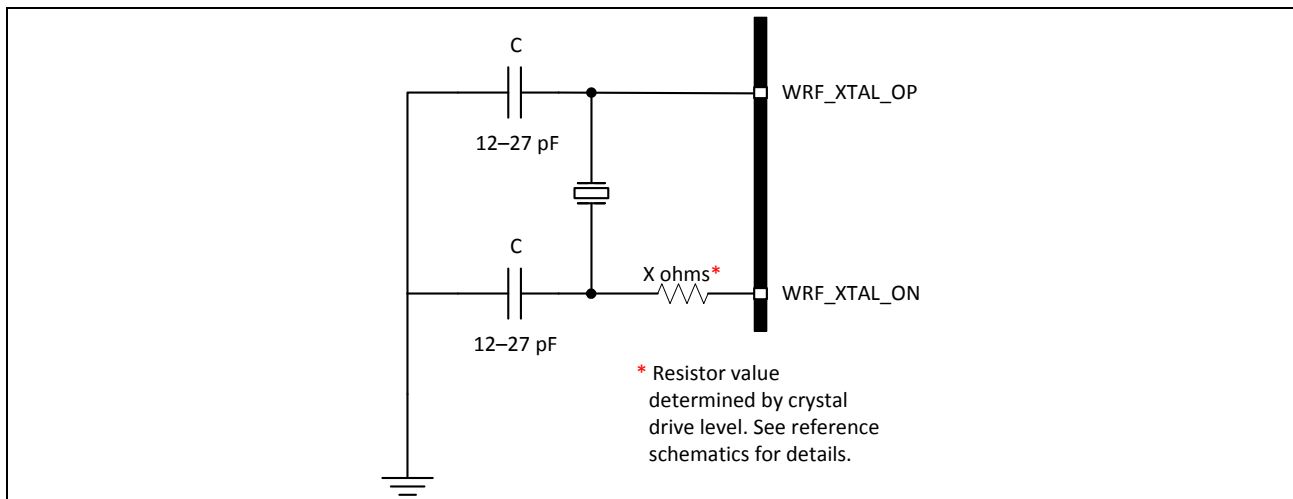

Figure 5: Recommended Oscillator Configuration

A fractional-N synthesizer in the BCM43241 generates the radio frequencies, clocks, and data/packet timing, enabling it to operate using a wide selection of frequency references.

The default frequency reference is a 37.4 MHz crystal or TCXO. The signal characteristics for the crystal interface are listed in [Table 2 on page 30](#).



Note: The fractional-N synthesizer can support alternative reference frequencies. Frequencies other than the default, however, require support to be added in the driver plus additional extensive system testing. Contact Broadcom for further details.

Not Recommended for New Designs

TCXO

As an alternative to a crystal, an external precision TCXO can be used as the frequency reference, provided that it meets the Phase Noise requirements listed in Table 2. When the clock is provided by an external TCXO, there are two possible connection methods, shown in Figure 6 and Figure 7:

1. If the TCXO is dedicated to driving the BCM43241, it should be connected to the WRF_XTAL_OP pin through an external 1000 pF coupling capacitor, as shown in Figure 6. The internal clock buffer connected to this pin will be turned OFF when the BCM43241 goes into sleep mode. When the clock buffer turns ON and OFF there will be a small impedance variation. Power must be supplied to the WRF_XTAL_VDD1P2 pin.
2. For 2.4 GHz operation only, an alternative is to DC-couple the TCXO to the WRF_TCXO_CK pin, as shown in Figure 7. Use this method when the same TCXO is shared with other devices and a change in the input impedance is not acceptable because it may cause a frequency shift that cannot be tolerated by the other device sharing the TCXO. This pin is connected to a clock buffer powered from WRF_TCXO_VDD. If the power supply to this buffer is always on (even in sleep mode), the clock buffer is always on, thereby ensuring a constant input impedance in all states of the device. The maximum current drawn from WRF_TCXO_VDD is approximately 500 μ A.

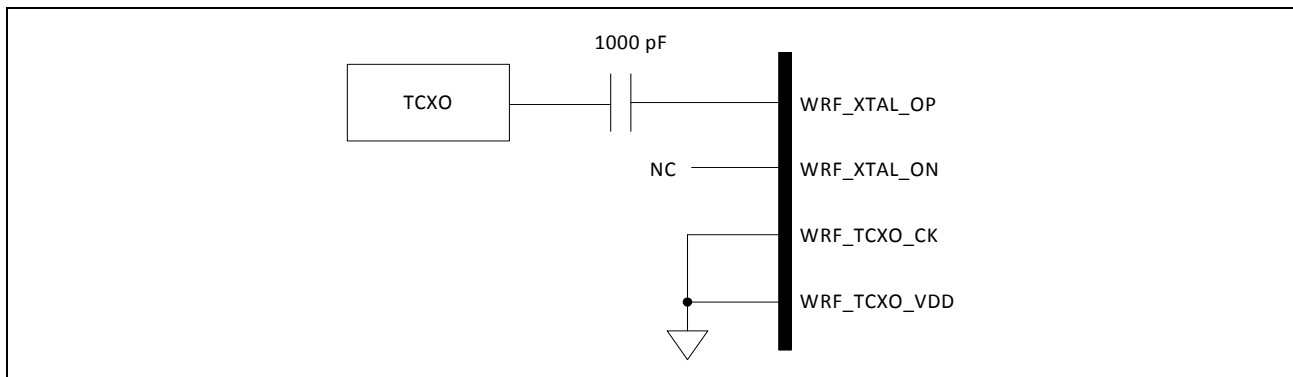

Figure 6: Recommended Circuit to Use with an External Dedicated TCXO

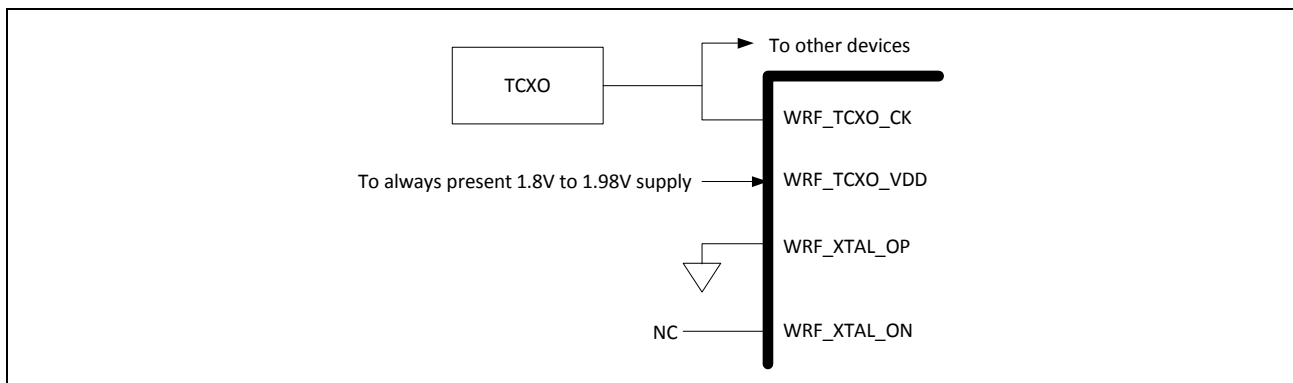

Figure 7: Recommended Circuit to Use with an External Shared TCXO

Not Recommended for New Designs

Table 2: Crystal Oscillator and External Clock – Requirements and Performance

Parameter	Conditions/Notes	Crystal ^a			External Frequency Reference ^{b c}			Units
		Min	Typ	Max	Min	Typ	Max	
Frequency	–	Between 12 MHz and 52 MHz ^d						
Crystal load capacitance	–	–	12	–	–	–	–	pF
ESR	–	–	–	60	–	–	–	Ω
Drive level	External crystal specification requirement	200	–	–	–	–	–	μW
Input impedance (WRF_XTAL_OP)	Resistive	–	–	–	12k	17k	–	Ω
	Capacitive	–	–	–	–	–	6	pF
Input impedance (WRF_TCXO_IN)	Resistive	–	–	–	17k	31k	–	Ω
	Capacitive	–	–	–	–	–	2	pF
WRF_XTAL_OP Input low level	DC-coupled digital signal	–	–	–	0	–	0.2	V
WRF_XTAL_OP Input high level	DC-coupled digital signal	–	–	–	1.0	–	1.26	V
WRF_XTAL_OP input voltage (see Figure 6)	AC-coupled analog signal	–	–	–	400	–	1200	mV _{p-p}
WRF_TCXO_IN Input voltage (see Figure 7)	DC-coupled analog signal	–	–	–	400	–	2500	mV _{p-p}
Frequency tolerance Initial + over temperature	Without trimming	–20	–	20	–20	–	20	ppm
Duty cycle	37.4 MHz clock	–	–	–	40	50	60	%
Phase Noise (IEEE 802.11b/g)	37.4 MHz clock at 10 kHz offset	–	–	–	–	–	–131	dBc/Hz
	37.4 MHz clock at 100 kHz or higher offset	–	–	–	–	–	–138	dBc/Hz
Phase Noise (IEEE 802.11a)	37.4 MHz clock at 10 kHz offset	–	–	–	–	–	–139	dBc/Hz
	37.4 MHz clock at 100 kHz or higher offset	–	–	–	–	–	–146	dBc/Hz
Phase Noise (IEEE 802.11n, 2.4 GHz)	37.4 MHz clock at 10 kHz offset	–	–	–	–	–	–136	dBc/Hz
	37.4 MHz clock at 100 kHz or higher offset	–	–	–	–	–	–143	dBc/Hz
Phase Noise (IEEE 802.11n, 5 GHz)	37.4 MHz clock at 10 kHz offset	–	–	–	–	–	–144	dBc/Hz
	37.4 MHz clock at 100 kHz or higher offset	–	–	–	–	–	–151	dBc/Hz

a. (Crystal) Use WRF_XTAL_OP and WRF_XTAL_ON, internal power to pin WRF_XTAL_VDD1P2.

b. (TCXO) See “TCXO” on page 29 for alternative connection methods.

Not Recommended for New Designs

- c. For a clock reference other than 37.4 MHz, $20 \times \log_{10}(f/37.4)$ dB should be added to the limits, where f = the reference clock frequency in MHz.
- d. The frequency step size is approximately 80 Hz resolution.

Frequency Selection

Any frequency within the ranges specified for the crystal and TCXO reference may be used. These include not only the standard handset reference frequencies of 12, 13, 14.4, 16.2, 16.8, 19.2, 19.44, 19.68, 19.8, 20, 26, 37.4, and 52 MHz, but also other frequencies in this range, with approximately 80 Hz resolution. The BCM43241 must have the reference frequency set correctly in order for any of the UART or PCM interfaces to function correctly, since all bit timing is derived from the reference frequency.



Note: The fractional-N synthesizer can support many reference frequencies. However, frequencies other than the default require support to be added in the driver plus additional, extensive system testing. Contact Broadcom for further details.

The reference frequency for the BCM43241 may be set in the following ways:

- Set the `xtalfreq=xxxxx` parameter in the `nvrn.txt` file (used to load the driver) to correctly match the crystal frequency.
- Autodetect any of the standard handset reference frequencies using an external LPO clock.

For applications such as handsets and portable smart communication devices, where the reference frequency is one of the standard frequencies commonly used, the BCM43241 automatically detects the reference frequency and programs itself to the correct reference frequency. In order for auto frequency detection to work correctly, the BCM43241 must have a valid and stable 32.768 kHz LPO clock that meets the requirements listed in [Table 3 on page 32](#) and is present during power-on reset.

External 32.768 kHz Low-Power Oscillator

The BCM43241 uses a secondary low-frequency clock for low-power-mode timing. Either the internal low-precision LPO or an external 32.768 kHz precision oscillator is required. The internal LPO frequency range is approximately 33 kHz \pm 30% over process, voltage, and temperature, which is adequate for some WLAN applications. However, one trade-off caused by this wide LPO tolerance is a small current consumption increase during power save mode that is incurred by the need to wake up earlier to avoid missing beacons.

Whenever possible, the preferred approach for WLAN is to use a precision external 32.768 kHz clock that meets the requirements listed in [Table 3](#). If Bluetooth or FM is used then the use of an external clock is always required.

Table 3: External 32.768 kHz Sleep Clock Specifications

Parameter	LPO Clock	Units
Nominal input frequency	32.768	kHz
Frequency accuracy	\pm 200	ppm
Duty cycle	30–70	%
Input signal amplitude	0.2–3.3	V, p-p
Signal type	Square-wave or sine-wave	–
Input impedance ^a	>100k	Ω
	<5	pF
Clock jitter (integrated over 300 Hz–15 kHz)	<5	ns
Clock jitter (during initial start-up)	<10,000	ppm

a. When power is applied or switched off.

Section 4: Bluetooth + FM Subsystem Overview

The Broadcom BCM43241 is a Bluetooth 4.0 + EDR-compliant baseband processor/2.4 GHz transceiver with an integrated FM/RDS/RBDS receiver. It features the highest level of integration and eliminates all critical external components, thus minimizing the footprint, power consumption, and system cost of a Bluetooth plus FM radio solution.

The BCM43241 is the optimal solution for any Bluetooth voice and/or data application that also requires an FM radio receiver. The Bluetooth subsystem presents a standard Host Controller Interface (HCI) via a high-speed UART and PCM for audio. The FM subsystem supports the HCI control interface, as well as I²S and PCM interfaces. The BCM43241 incorporates all Bluetooth 4.0 features including Secure Simple Pairing, Sniff Subrating, as well as Encryption Pause and Resume.

The BCM43241 Bluetooth radio transceiver provides enhanced radio performance to meet the most stringent mobile phone temperature applications and the tightest integration into mobile handsets and portable devices. It is fully compatible with any of the standard TCXO frequencies and provides full radio compatibility to operate simultaneously with GPS, WLAN, and cellular radios.

The Bluetooth transmitter also features a Class 1 power amplifier with Class 2 capability.

Features

Major Bluetooth features of the BCM43241 include:

- Supports key features of upcoming Bluetooth standards
- Fully supports Bluetooth Core Specification version 4.0 + (Enhanced Data Rate) EDR features:
 - Adaptive Frequency Hopping (AFH)
 - Quality of Service (QoS)
 - Extended Synchronous Connections (eSCO) — Voice Connections
 - Fast Connect (interlaced page and inquiry scans)
 - Secure Simple Pairing (SSP)
 - Sniff Subrating (SSR)
 - Encryption Pause Resume (EPR)
 - Extended Inquiry Response (EIR)
 - Link Supervision Timeout (LST)
- UART baud rates up to 4 Mbps
- Supports all Bluetooth 4.0 + HS packet types
- Supports maximum Bluetooth data rates over HCI UART
- Multipoint operation with up to seven active slaves
 - Maximum of seven simultaneous active ACL links
 - Maximum of three simultaneous active SCO and eSCO connections with scatternet support

- Trigger Broadcom fast connect (TBFC)
- Narrowband and wideband packet loss concealment
- Scatternet operation with up to four active piconets with background scan and support for scatter mode
- High-speed HCI UART transport support with low-power out-of-band BT_DEV_WAKE and BT_HOST_WAKE signaling (see “Host Controller Power Management” on page 39)
- Channel quality driven data rate and packet type selection
- Standard Bluetooth test modes
- Extended radio and production test mode features
- Full support for power savings modes
 - Bluetooth clock request
 - Bluetooth standard sniff
 - Deep-sleep modes and software regulator shutdown
- TCXO input and autodetection of all standard handset clock frequencies. Also supports a low-power crystal, which can be used during power save mode for better timing accuracy.

Major FM Radio features include:

- 65 MHz to 108 MHz FM bands supported (US, Europe, and Japan)
- FM subsystem control using the Bluetooth HCI interface
- FM subsystem operates from the system clock
- Improved audio interface capabilities with full-featured bidirectional PCM and I²S
- I²S can be master or slave.

FM Receiver-Specific Features Include:

- Excellent FM radio performance with 1 μ V sensitivity for 26 dB (S+N)/N
- Signal-dependent stereo/mono blending
- Signal-dependent soft mute
- Auto search and tuning modes
- Audio silence detection
- RDS and RBDS demodulator and decoder with filter and buffering functions
- Automatic frequency jump

Bluetooth Radio

The BCM43241 has an integrated radio transceiver that has been optimized for use in 2.4 GHz Bluetooth wireless systems. It has been designed to provide low-power, low-cost, robust communications for applications operating in the globally available 2.4 GHz unlicensed ISM band. It is fully compliant with the Bluetooth Radio Specification and EDR specification and meets or exceeds the requirements to provide the highest communication link quality of service.

Transmit

The BCM43241 features a fully integrated zero-IF transmitter. The baseband transmit data is GFSK-modulated in the modem block and upconverted to the 2.4 GHz ISM band in the transmitter path. The transmitter path consists of signal filtering, I/Q upconversion, output power amplifier, and RF filtering. The transmitter path also incorporates $\pi/4$ -DQPSK for 2 Mbps and 8-DPSK for 3 Mbps to support EDR. The transmitter section is compatible with the Bluetooth Low Energy specification. The transmitter PA bias can also be adjusted to provide Bluetooth class 1 or class 2 operation.

Digital Modulator

The digital modulator performs the data modulation and filtering required for the GFSK, $\pi/4$ -DQPSK, and 8-DPSK signal. The fully digital modulator minimizes any frequency drift or anomalies in the modulation characteristics of the transmitted signal and is much more stable than direct VCO modulation schemes.

Digital Demodulator and Bit Synchronizer

The digital demodulator and bit synchronizer take the low-IF received signal and perform an optimal frequency tracking and bit-synchronization algorithm.

Power Amplifier

The fully integrated PA supports Class 1 or Class 2 output using a highly linearized, temperature-compensated design. This provides greater flexibility in front-end matching and filtering. Due to the linear nature of the PA combined with some integrated filtering, external filtering is required to meet the Bluetooth and regulatory harmonic and spurious requirements. For integrated mobile handset applications in which Bluetooth is integrated next to the cellular radio, external filtering can be applied to achieve near thermal noise levels for spurious and radiated noise emissions. The transmitter features a sophisticated on-chip transmit signal strength indicator (TSSI) block to keep the absolute output power variation within a tight range across process, voltage, and temperature.

Receiver

The receiver path uses a low-IF scheme to downconvert the received signal for demodulation in the digital demodulator and bit synchronizer. The receiver path provides a high degree of linearity, an extended dynamic range, and high-order on-chip channel filtering to ensure reliable operation in the noisy 2.4 GHz ISM band. The front-end topology with built-in out-of-band attenuation enables the BCM43241 to be used in most applications with minimal off-chip filtering. For integrated handset operation, in which the Bluetooth function is integrated close to the cellular transmitter, external filtering is required to eliminate the desensitization of the receiver by the cellular transmit signal.

Digital Demodulator and Bit Synchronizer

The digital demodulator and bit synchronizer take the low-IF received signal and perform an optimal frequency tracking and bit synchronization algorithm.

Receiver Signal Strength Indicator

The radio portion of the BCM43241 provides a Receiver Signal Strength Indicator (RSSI) signal to the baseband, so that the controller can take part in a Bluetooth power-controlled link by providing a metric of its own receiver signal strength to determine whether the transmitter should increase or decrease its output power.

Local Oscillator Generation

Local Oscillator (LO) generation provides fast frequency hopping (1600 hops/second) across the 79 maximum available channels. The LO generation subblock employs an architecture for high immunity to LO pulling during PA operation. The BCM43241 uses an internal RF and IF loop filter.

Calibration

The BCM43241 radio transceiver features an automated calibration scheme that is fully self-contained in the radio. No user interaction is required during normal operation or during manufacturing to provide the optimal performance. Calibration optimizes the performance of all the major blocks within the radio to within 2% of optimal conditions, including gain and phase characteristics of filters, matching between key components, and key gain blocks. This takes into account process variation and temperature variation. Calibration occurs transparently during normal operation throughout the settling time of the hops and calibrates for temperature variations as the device cools and heats during normal operation in its environment.

Section 5: Bluetooth Baseband Core

The Bluetooth Baseband Core (BBC) implements all of the time-critical functions required for high-performance Bluetooth operation. The BBC manages the buffering, segmentation, and routing of data for all connections. It also buffers data that passes through it, handles data flow control, schedules SCO/ACL TX/RX transactions, monitors Bluetooth slot usage, optimally segments and packages data into baseband packets, manages connection status indicators, and composes and decodes HCI packets. In addition to these functions, it independently handles HCI event types and HCI command types.

The following transmit and receive functions are also implemented in the BBC hardware to increase reliability and security of the TX/RX data before sending over the air:

- Symbol timing recovery, data deframing, forward error correction (FEC), header error control (HEC), cyclic redundancy check (CRC), data decryption, and data dewatering in the receiver.
- Data framing, FEC generation, HEC generation, CRC generation, key generation, data encryption, and data whitening in the transmitter.

Bluetooth 4.0 Features

The BBC supports all Bluetooth 4.0 features, with the following benefits:

- Dual-mode bluetooth Low Energy (BT and BLE operation)
- Extended Inquiry Response (EIR): Shortens the time to retrieve the device name, specific profile, and operating mode.
- Encryption Pause Resume (EPR): Enables the use of Bluetooth technology in a much more secure environment.
- Sniff Subrating (SSR): Optimizes power consumption for low duty cycle asymmetric data flow, which subsequently extends battery life.
- Secure Simple Pairing (SSP): Reduces the number of steps for connecting two devices, with minimal or no user interaction required.
- Link Supervision Time Out (LSTO): Additional commands added to HCI and Link Management Protocol (LMP) for improved link time-out supervision.
- QoS enhancements: Changes to data traffic control, which results in better link performance. Audio, human interface device (HID), bulk traffic, SCO, and enhanced SCO (eSCO) are improved with the erroneous data (ED) and packet boundary flag (PBF) enhancements.

Bluetooth Low Energy

The BCM43241 is forward compatible with the impending Bluetooth Low Energy operating mode, which provides a dramatic reduction in the power consumption of the Bluetooth radio and baseband. The primary application for this mode is to provide support for low data rate devices, such as sensors and remote controls.

Link Control Layer

The link control layer is part of the Bluetooth link control functions that are implemented in dedicated logic in the link control unit (LCU). This layer consists of the command controller, which takes commands from the software, and other controllers, which are activated or configured by the command controller, to perform the link control tasks. Each task performs a different state in the Bluetooth Link Controller.

- Major states:
 - Standby
 - Connection
- Substates:
 - Page
 - Page Scan
 - Inquiry
 - Inquiry Scan
 - Sniff

Test Mode Support

The BCM43241 fully supports Bluetooth Test mode as described in Part I:1 of the *Specification of the Bluetooth System Version 3.0*. This includes the transmitter tests, normal and delayed loopback tests, and reduced hopping sequence.

In addition to the standard Bluetooth Test Mode, the BCM43241 also supports enhanced testing features to simplify RF debugging and qualification and type-approval testing. These features include:

- Fixed frequency carrier wave (unmodulated) transmission
 - Simplifies some type-approval measurements (Japan)
 - Aids in transmitter performance analysis
- Fixed frequency constant receiver mode
 - Receiver output directed to I/O pin
 - Allows for direct BER measurements using standard RF test equipment
 - Facilitates spurious emissions testing for receive mode
- Fixed frequency constant transmission
 - 8-bit fixed pattern or PRBS-9
 - Enables modulated signal measurements with standard RF test equipment

Bluetooth Power Management Unit

The Bluetooth Power Management Unit (PMU) provides power management features that can be invoked by either software through power management registers or packet handling in the baseband core. The power management functions provided by the BCM43241 are:

- [RF Power Management](#)
- [Host Controller Power Management](#)
- [BBC Power Management](#)
- [FM Power Management](#)

RF Power Management

The BBC generates power-down control signals for the transmit path, receive path, PLL, and power amplifier to the 2.4 GHz transceiver. The transceiver then processes the power-down functions accordingly.

Host Controller Power Management

When running in UART mode, the BCM43241 may be configured so that dedicated signals are used for power management handshaking between the BCM43241 and the host. The basic power saving functions supported by those handshaking signals include the standard Bluetooth-defined power saving modes and standby modes of operation.

Table 4 describes the power-control handshake signals used with the UART interface.

Table 4: Power Control Pin Description

Signal	Mapped to Pin	Type	Description
BT_DEV_WAKE	BT_GPIO_0	I	Bluetooth device wake-up: Signal from the host to the BCM43241 indicating that the host requires attention. <ul style="list-style-type: none"> • Asserted: The Bluetooth device must wake up or remain awake. • Deasserted: The Bluetooth device may sleep when sleep criteria are met. The polarity of this signal is software configurable and can be asserted high or low.
BT_HOST_WAKE	BT_GPIO_1	O	Host wake-up. Signal from the BCM43241 to the host indicating that the BCM43241 requires attention. <ul style="list-style-type: none"> • Asserted: Host device must wake up or remain awake. • Deasserted: Host device may sleep when sleep criteria are met. The polarity of this signal is software configurable and can be asserted high or low.
CLK_REQ	BT_CLK_REQ_OUT WL_CLK_REQ_OUT	O	The BCM43241 asserts CLK_REQ when Bluetooth or WLAN wants the host to turn on the reference clock. The CLK_REQ polarity is active-high.

Table 4: Power Control Pin Description (Cont.)

Signal	Mapped to Pin	Type	Description
--------	---------------	------	-------------

Note: Pad function Control Register is set to 0 for these pins. See “Multiplexed Bluetooth GPIO Signals” on page 101 for more details.

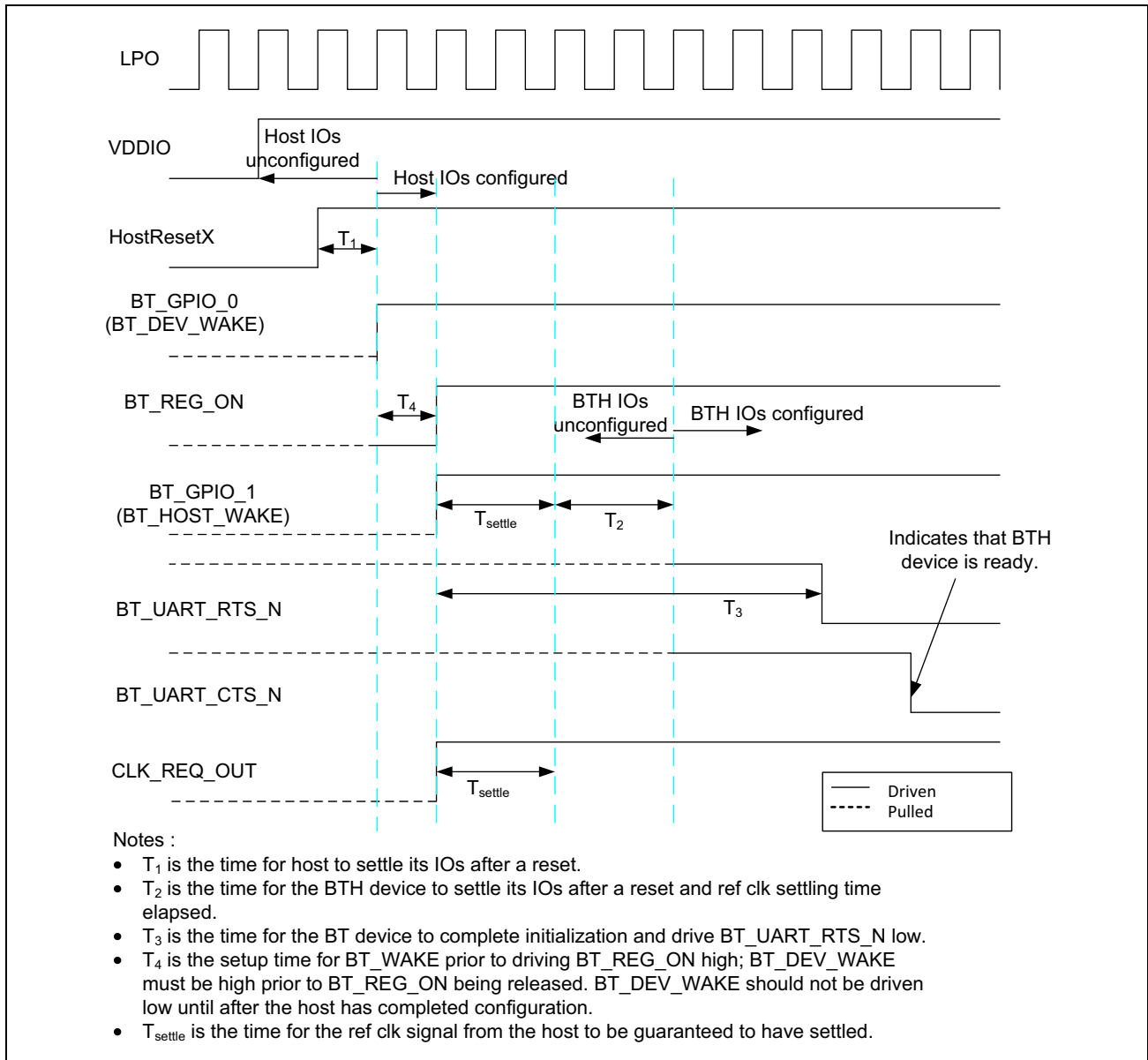

Figure 8: Start-up Signaling Sequence

BBC Power Management

The following are low-power operations for the BBC:

Not Recommended for New Designs

- Physical layer packet-handling turns the RF on and off dynamically within transmit/receive packets.
- Bluetooth-specified low-power connection modes: sniff, hold, and park. While in these modes, the BCM43241 runs on the low-power oscillator and wakes up after a predefined time period.
- A low-power shutdown feature allows the device to be turned off while the host and any other devices in the system remain operational. When the BCM43241 is not needed in the system, the RF and core supplies are shut down while the I/O remains powered. This allows the BCM43241 to effectively be off while keeping the I/O pins powered so they do not draw extra current from any other devices connected to the I/O.

During the low-power shutdown state, provided VDDIO remains applied to the BCM43241, all outputs/inputs keep their existing states. Input voltages must remain within the limits defined for normal operation. This is done to prevent current paths or create loading on any digital signals in the system and enables the BCM43241 to be fully integrated in an embedded device to take full advantage of the lowest power-saving modes.

Two BCM43241 input signals are designed to be high-impedance inputs that do not load the driving signal even if the chip does not have VDDIO power supplied to it: the frequency reference input (WRF_TCXO_IN) and the 32.768 kHz input (LPO). When the BCM43241 is powered on from this state, it is the same as a normal power-up, and the device does not contain any information about its state from the time before it was powered down.

FM Power Management

The BCM43241 FM subsystem can operate independently of, or in tandem with, the Bluetooth RF and BBC subsystems. The FM subsystem power management scheme operates in conjunction with the Bluetooth RF and BBC subsystems. The FM block does not have a low power state, it is either on or off.

Wideband Speech

The BCM43241 provides support for wideband speech (WBS) using on-chip Smart Audio technology. The BCM43241 can perform subband-codec (SBC), as well as mSBC, encoding and decoding of linear 16 bits at 16 kHz (256 Kbps rate) transferred over the PCM bus.

Packet Loss Concealment

Packet Loss Concealment (PLC) improves apparent audio quality for systems with marginal link performance. Bluetooth messages are sent in packets. When a packet is lost, it creates a gap in the received audio bitstream. Packet loss can be mitigated in several ways:

- Fill in zeros.
- Ramp down the output audio signal toward zero (this is the method used in current Bluetooth headsets).
- Repeat the last frame (or packet) of the received bitstream and decode it as usual (frame repeat).

These techniques cause distortion and popping in the audio stream. The BCM43241 uses a proprietary waveform extension algorithm to provide dramatic improvement in the audio quality. [Figure 9](#) and [Figure 10](#) show audio waveforms with and without Packet Loss Concealment. Broadcom PLC/BEC algorithms also support wideband speech.

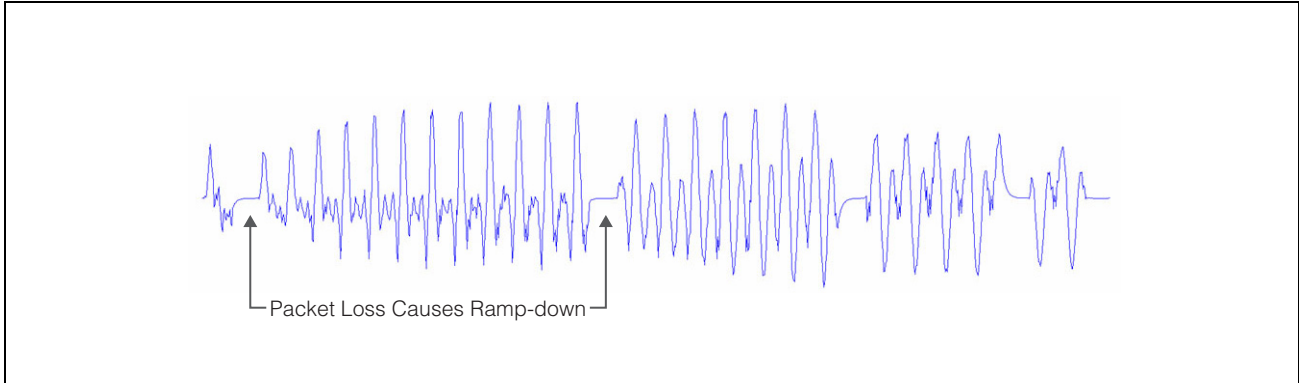

Figure 9: CVSD Decoder Output Waveform Without PLC

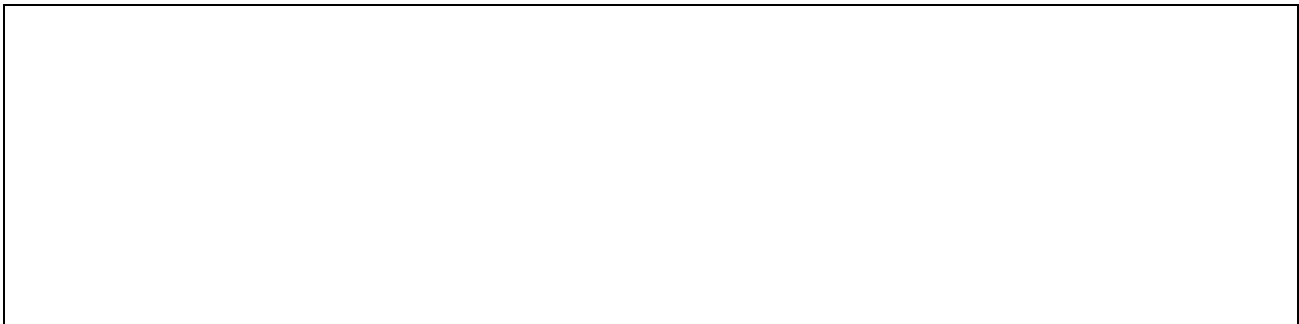

Figure 10: CVSD Decoder Output Waveform After Applying PLC

Audio Rate-Matching Algorithms

The BCM43241 has an enhanced rate-matching algorithm that uses interpolation algorithms to reduce audio stream jitter that may be present when the rate of audio data coming from the host is not the same as the Bluetooth or FM audio data rates.

Codec Encoding

The BCM43241 can support SBC and mSBC encoding and decoding for wideband speech.

Multiple Simultaneous A2DP Audio Stream

The BCM43241 has the ability to take a single audio stream and output it to multiple Bluetooth devices simultaneously. This allows a user to share his or her music (or any audio stream) with a friend.

FM Over Bluetooth

FM Over Bluetooth enables the BCM43241 to stream data from FM over Bluetooth without requiring the host to be awake. This can significantly extend battery life for usage cases where someone is listening to FM radio on a Bluetooth headset.

Burst Buffer Operation

The BCM43241 has a data buffer that can buffer data being sent over the HCI and audio transports, then send the data at an increased rate. This mode of operation allows the host to sleep for the maximum amount of time, dramatically reducing system current consumption.

Adaptive Frequency Hopping

The BCM43241 gathers link quality statistics on a channel by channel basis to facilitate channel assessment and channel map selection. The link quality is determined using both RF and baseband signal processing to provide a more accurate frequency-hop map.

Advanced Bluetooth/WLAN Coexistence

The BCM43241 includes advanced coexistence technologies that are only possible with a Bluetooth/WLAN integrated die solution. These coexistence technologies are targeted at small form-factor platforms, such as cell phones and media players, including applications such as VoWLAN + SCO and Video-over-WLAN + High Fidelity BT Stereo.

Support is provided for platforms that share a single antenna between Bluetooth and WLAN. Dual-antenna applications are also supported. The BCM43241 radio architecture allows for lossless simultaneous Bluetooth and WLAN reception for shared antenna applications. This is possible only via an integrated solution (shared LNA and joint AGC algorithm). It has superior performance versus implementations that need to arbitrate between Bluetooth and WLAN reception.

The BCM43241 integrated solution enables MAC-layer signaling (firmware) and a greater degree of sharing via an enhanced coexistence interface. Information is exchanged between the Bluetooth and WLAN cores without host processor involvement.

The BCM43241 also supports Transmit Power Control on the STA together with standard Bluetooth TPC to limit mutual interference and receiver desensitization. Preemption mechanisms are utilized to prevent AP transmissions from colliding with Bluetooth frames. Improved channel classification techniques have been implemented in Bluetooth for faster and more accurate detection and elimination of interferers (including non-WLAN 2.4 GHz interference).

The Bluetooth AFH classification is also enhanced by the WLAN core's channel information.

Fast Connection (Interlaced Page and Inquiry Scans)

The BCM43241 supports page scan and inquiry scan modes that significantly reduce the average inquiry response and connection times. These scanning modes are compatible with the Bluetooth version 2.1 page and inquiry procedures.

Not Recommended for New Designs

Section 6: Music and Audio

The BCM43241 provides superior total system current during music or audio playback and recording. To enable these functions, several features of the device are combined to provide superior system power consumption.

MP3 Encoder

- ISO/IEC 11172-3 compliant
- Supports 32 kHz sampling frequencies only
- Encodes mono and stereo signals

MP3 Decoder

The MP3 decoder supports mono and stereo audio recording with the following specifications:

- Supports MPEG-1 Layer 3 decoding
- Output is fully bit compliant with MPEG-1 standard specification
- Supports sampling frequencies from 32 kHz to 48 kHz
- Minimum bit-rate supported 32 Kbps and maximum bit-rate supported 320 Kbps for Layer 3

AAC/AAC+ Decoder

Compliant to ISO/IEC 14496-3: 2004 specifications:

- MPEG-2, MPEG-4 AAC LC decoding up to level 2
- SBR tool, up to level 3
- Low power SBR tool
- Full support up to level 3 for the HE AAC profile
- Implicit and explicit SBR signaling mechanisms
- Mono and stereo channel streams decoding sampling frequencies from 8 kHz to 96 kHz only
- ADTS frame decoding

Section 7: Microprocessor and Memory Unit for Bluetooth

The Bluetooth microprocessor core is based on the ARM® Cortex-M3™ 32-bit RISC processor with embedded ICE-RT debug and JTAG interface units. It runs software from the link control (LC) layer, up to the host controller interface (HCI).

The ARM core is paired with a memory unit that contains ROM memory for program storage and boot ROM, and RAM for data scratchpad and patch RAM code. The internal ROM allows for flexibility during power-on reset to enable the same device to be used in various configurations. At power-up, the lower-layer protocol stack is executed from the internal ROM memory.

External patches may be applied to the ROM-based firmware to provide flexibility for bug fixes or features additions. These patches may be downloaded from the host to the BCM43241 through the UART transports. The mechanism for downloading via UART is identical to the proven interface of the BCM4329 and BCM4330 devices.

RAM, ROM, and Patch Memory

The BCM43241 Bluetooth core has internal RAM, which is mapped between general-purpose scratch pad memory and patch memory, and ROM, which is used for the lower-layer protocol stack, test mode software, and boot ROM. The patch memory capability enables the addition of code changes for purposes of feature additions and bug fixes to the ROM memory.

Reset

The BCM43241 has an integrated power-on reset circuit that resets all circuits to a known power-on state. The BT power-on reset (POR) circuit is out of reset after BT_REG_ON goes High. If BT_REG_ON is low, then the POR circuit is held in reset.

Section 8: Bluetooth Peripheral Transport Unit

PCM Interface

The BCM43241 supports two independent PCM interfaces that share the pins with the I²S interfaces. The PCM Interface on the BCM43241 can connect to linear PCM Codec devices in master or slave mode. In master mode, the BCM43241 generates the PCM_CLK and PCM_SYNC signals, and in slave mode, these signals are provided by another master on the PCM interface and are inputs to the BCM43241.

The configuration of the PCM interface may be adjusted by the host through the use of vendor-specific HCI commands.

Slot Mapping

The BCM43241 supports up to three simultaneous full-duplex SCO or eSCO channels through the PCM interface. These three channels are time-multiplexed onto the single PCM interface by using a time-slotting scheme where the 8 kHz or 16 kHz audio sample interval is divided into as many as 16 slots. The number of slots is dependent on the selected interface rate of 128 kHz, 512 kHz, or 1024 kHz. The corresponding number of slots for these interface rate is 1, 2, 4, 8, and 16, respectively. Transmit and receive PCM data from an SCO channel is always mapped to the same slot. The PCM data output driver tristates its output on unused slots to allow other devices to share the same PCM interface signals. The data output driver tristates its output after the falling edge of the PCM clock during the last bit of the slot.

Frame Synchronization

The BCM43241 supports both short- and long-frame synchronization in both master and slave modes. In short-frame synchronization mode, the frame synchronization signal is an active-high pulse at the audio frame rate that is a single-bit period in width and is synchronized to the rising edge of the bit clock. The PCM slave looks for a high on the falling edge of the bit clock and expects the first bit of the first slot to start at the next rising edge of the clock. In long-frame synchronization mode, the frame synchronization signal is again an active-high pulse at the audio frame rate; however, the duration is 3-bit periods, and the pulse starts coincident with the first bit of the first slot.

Data Formatting

The BCM43241 may be configured to generate and accept several different data formats. For conventional narrowband speech mode, the BCM43241 uses 13 of the 16 bits in each PCM frame. The location and order of these 13 bits can be configured to support various data formats on the PCM interface. The remaining three bits are ignored on the input and may be filled with 0s, 1s, a sign bit, or a programmed value on the output. The default format is 13-bit 2's complement data, left justified, and clocked MSB first.

Wideband Speech Support

When the host encodes Wideband Speech (WBS) packets in transparent mode, the encoded packets are transferred over the PCM bus for an eSCO voice connection. In this mode, the PCM bus is typically configured in master mode for a 4 kHz sync rate with 16-bit samples, resulting in a 64 Kbps bit rate. The BCM43241 also supports slave transparent mode using a proprietary rate-matching scheme. In SBC-code mode, linear 16-bit data at 16 kHz (256 Kbps rate) is transferred over the PCM bus.

Multiplexed Bluetooth and FM Over PCM

In this mode of operation, the BCM43241 multiplexes both FM and Bluetooth audio PCM channels over the same interface, reducing the number of required I/Os. This mode of operation is initiated through an HCI command from the host. The format of the data stream consists of three channels: a Bluetooth channel followed by two FM channels (audio left and right). In this mode of operation, the bus data rate only supports 48 kHz operation per channel with 16 bits sent for each channel. This is done to allow the low data rate Bluetooth data to coexist in the same interface as the higher speed I²S data. To accomplish this, the Bluetooth data is repeated six times for 8 kHz data and three times for 16 kHz data. An initial sync pulse on the PCM_SYNC line is used to indicate the beginning of the frame.

To support multiple Bluetooth audio streams within the Bluetooth channel, both 16 kHz and 8 kHz streams can be multiplexed. This mode of operation is only supported when the Bluetooth host is the master. Figure 11 shows the operation of the multiplexed transport with three simultaneous SCO connections. To accommodate additional SCO channels, the transport clock speed is increased. To change between modes of operation, the transport must be halted and restarted in the new configuration.

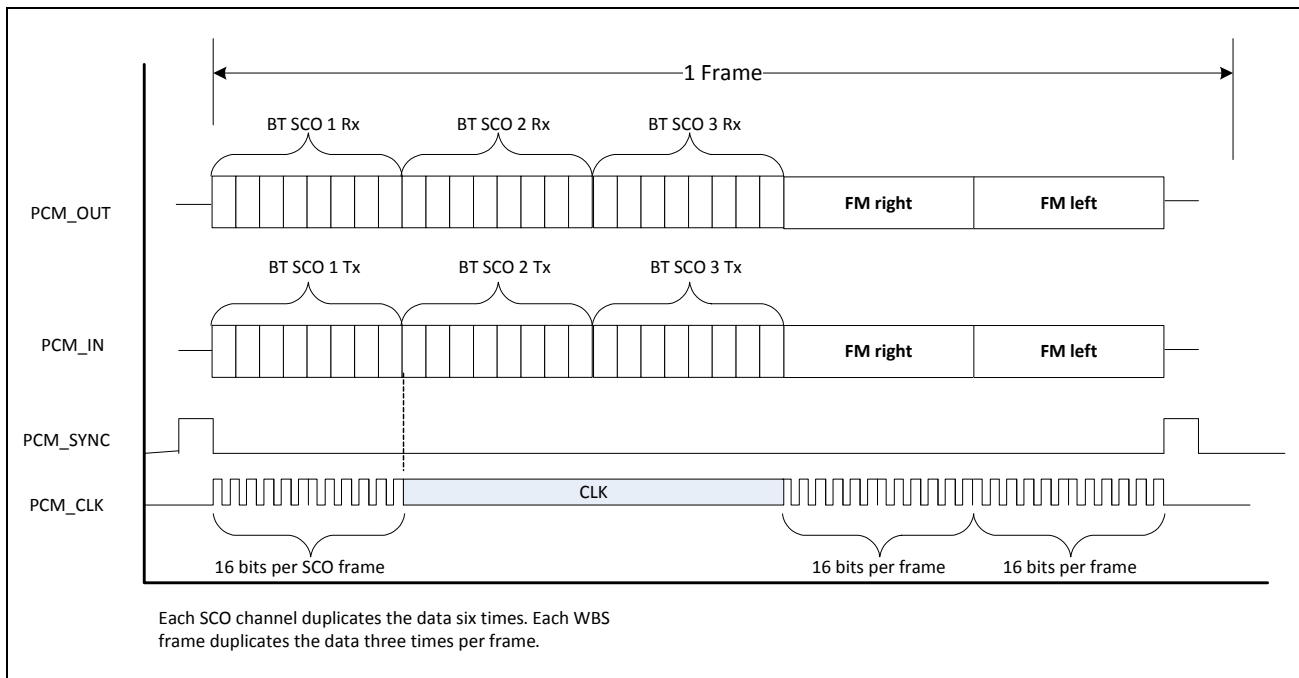

Figure 11: Functional Multiplex Data Diagram

Not Recommended for New Designs

Burst PCM Mode

In this mode of operation, the PCM bus runs at a significantly higher rate of operation to allow the host to duty cycle its operation and save current. Also, the PCM bus can operate at a rate of up to 24 MHz in this mode. This mode of operation is initiated with an HCI command from the host.

Not Recommended for New Designs

PCM Interface Timing

Short Frame Sync, Master Mode

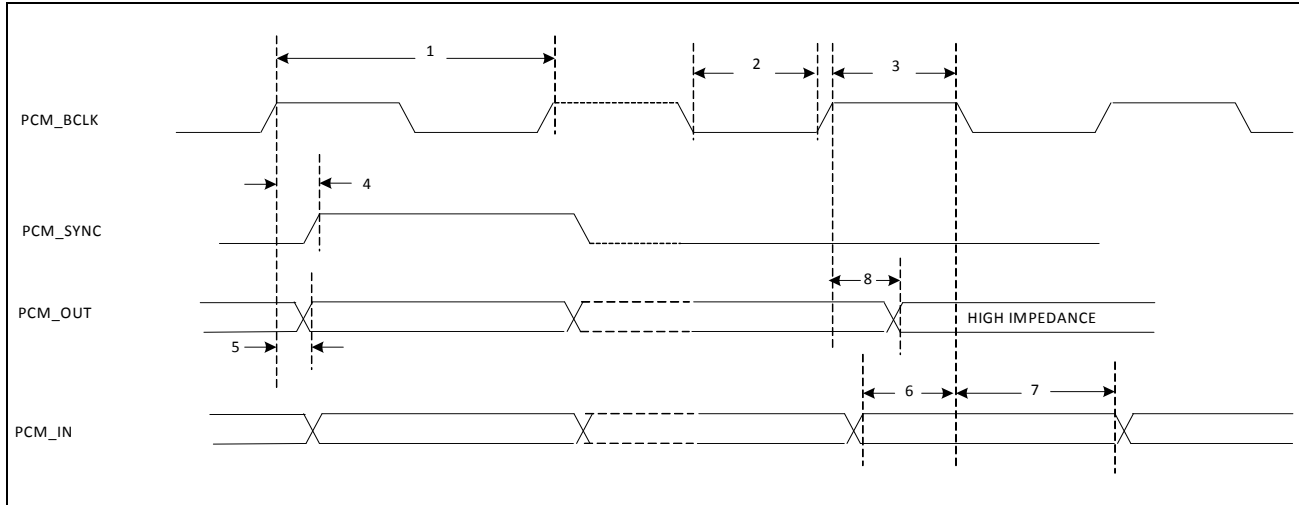

Figure 12: PCM Timing Diagram (Short Frame Sync, Master Mode)

Table 5: PCM Interface Timing Specifications (Short Frame Sync, Master Mode)

Ref No.	Characteristics	Minimum	Typical	Maximum	Unit
1	PCM bit clock frequency	–	–	12	MHz
2	PCM bit clock HIGH	41	–	–	ns
3	PCM bit clock LOW	41	–	–	ns
4	PCM_SYNC delay	0	–	25	ns
5	PCM_OUT delay	0	–	25	ns
6	PCM_IN setup	8	–	–	ns
7	PCM_IN hold	8	–	–	ns
8	Delay from rising edge of PCM_BCLK during last bit period to PCM_OUT becoming high impedance	0	–	25	ns

Not Recommended for New Designs

Short Frame Sync, Slave Mode

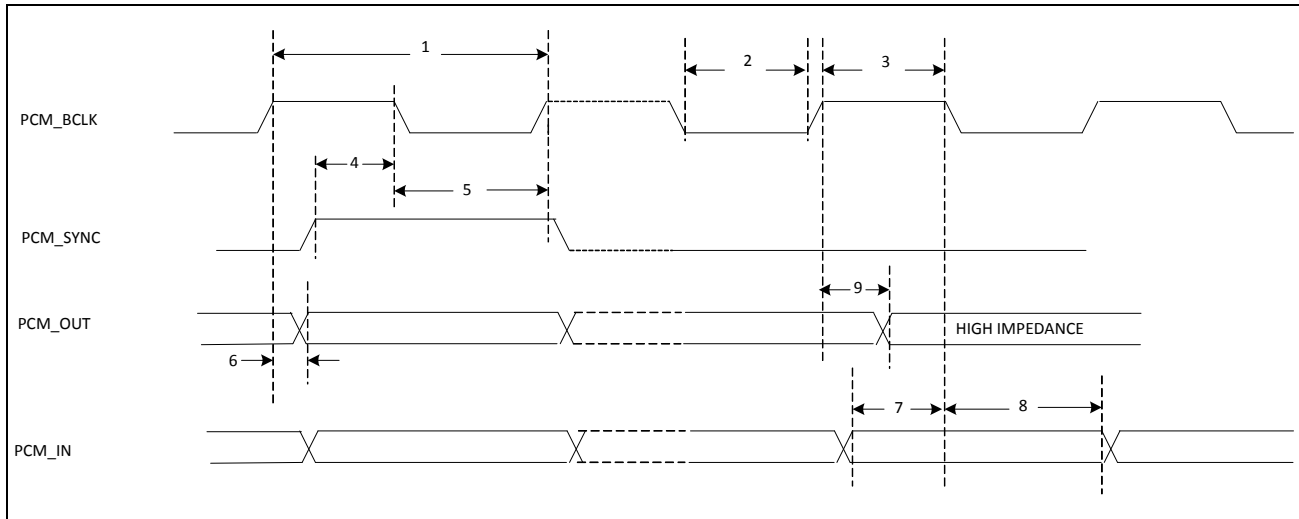

Figure 13: PCM Timing Diagram (Short Frame Sync, Slave Mode)

Table 6: PCM Interface Timing Specifications (Short Frame Sync, Slave Mode)

Ref No.	Characteristics	Minimum	Typical	Maximum	Unit
1	PCM bit clock frequency	–	–	12	MHz
2	PCM bit clock HIGH	41	–	–	ns
3	PCM bit clock LOW	41	–	–	ns
4	PCM_SYNC setup	8	–	–	ns
5	PCM_SYNC hold	8	–	–	ns
6	PCM_OUT delay	0	–	25	ns
7	PCM_IN setup	8	–	–	ns
8	PCM_IN hold	8	–	–	ns
9	Delay from rising edge of PCM_BCLK during last bit period to PCM_OUT becoming high impedance	0	–	25	ns

Not Recommended for New Designs

Long Frame Sync, Master Mode

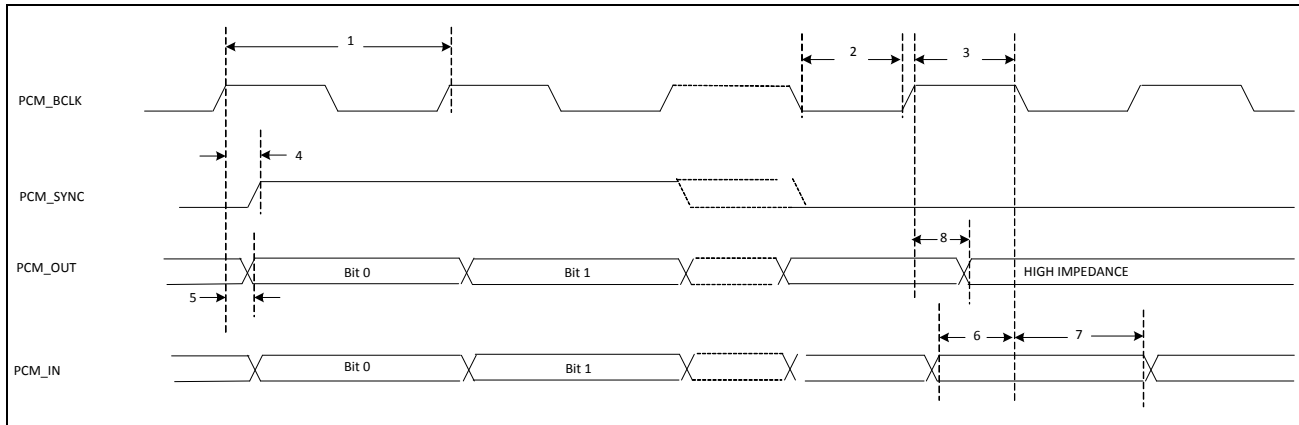

Figure 14: PCM Timing Diagram (Long Frame Sync, Master Mode)

Table 7: PCM Interface Timing Specifications (Long Frame Sync, Master Mode)

Ref No.	Characteristics	Minimum	Typical	Maximum	Unit
1	PCM bit clock frequency	–	–	12	MHz
2	PCM bit clock HIGH	41	–	–	ns
3	PCM bit clock LOW	41	–	–	ns
4	PCM_SYNC delay	0	–	25	ns
5	PCM_OUT delay	0	–	25	ns
6	PCM_IN setup	8	–	–	ns
7	PCM_IN hold	8	–	–	ns
8	Delay from rising edge of PCM_BCLK during last bit period to PCM_OUT becoming high impedance	0	–	25	ns

Not Recommended for New Designs

Long Frame Sync, Slave Mode

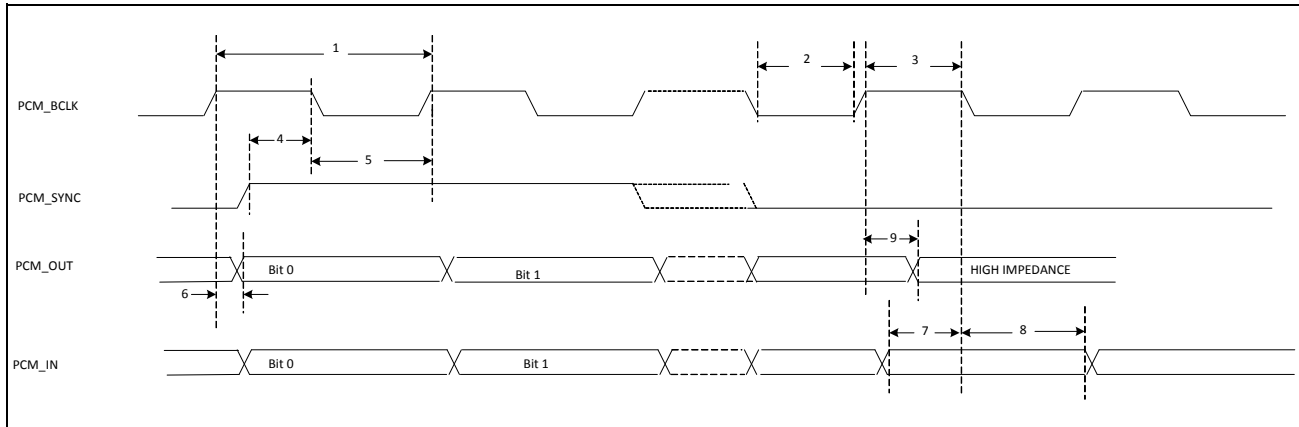

Figure 15: PCM Timing Diagram (Long Frame Sync, Slave Mode)

Table 8: PCM Interface Timing Specifications (Long Frame Sync, Slave Mode)

Ref No.	Characteristics	Minimum	Typical	Maximum	Unit
1	PCM bit clock frequency	–	–	12	MHz
2	PCM bit clock HIGH	41	–	–	ns
3	PCM bit clock LOW	41	–	–	ns
4	PCM_SYNC setup	8	–	–	ns
5	PCM_SYNC hold	8	–	–	ns
6	PCM_OUT delay	0	–	25	ns
7	PCM_IN setup	8	–	–	ns
8	PCM_IN hold	8	–	–	ns
9	Delay from rising edge of PCM_BCLK during last bit period to PCM_OUT becoming high impedance	0	–	25	ns

Not Recommended for New Designs

Short Frame Sync, Burst Mode

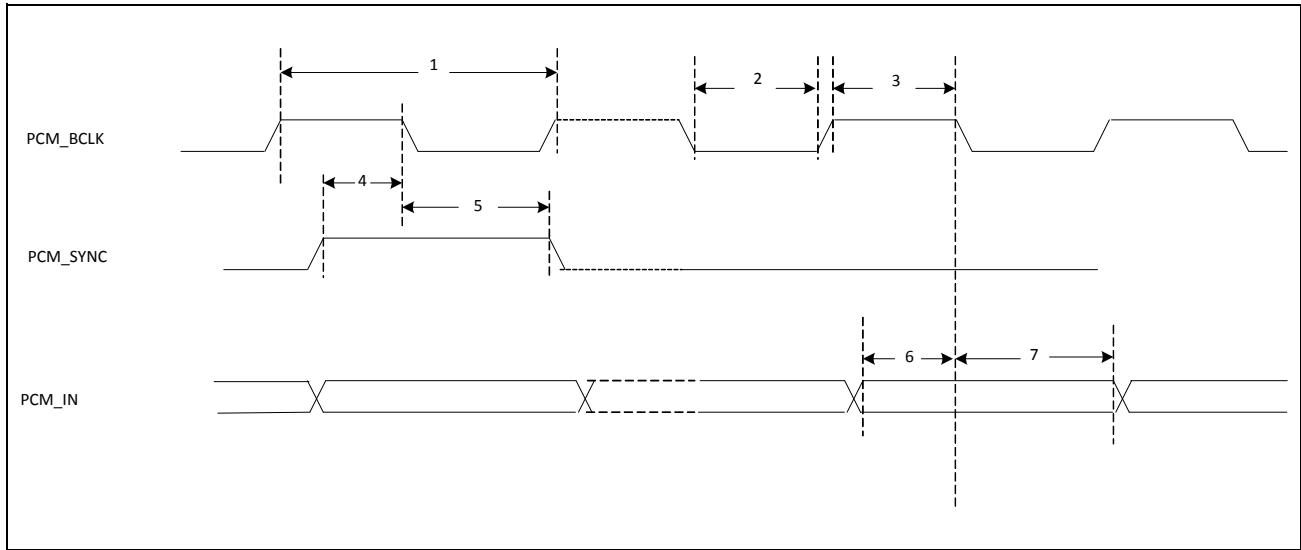

Figure 16: PCM Burst Mode Timing (Receive Only, Short Frame Sync)

Table 9: PCM Burst Mode (Receive Only, Short Frame Sync)

Ref No.	Characteristics	Minimum	Typical	Maximum	Unit
1	PCM bit clock frequency	–	–	24	MHz
2	PCM bit clock HIGH	20.8	–	–	ns
3	PCM bit clock LOW	20.8	–	–	ns
4	PCM_SYNC setup	8	–	–	ns
5	PCM_SYNC hold	8	–	–	ns
6	PCM_IN setup	8	–	–	ns
7	PCM_IN hold	8	–	–	ns

Not Recommended for New Designs

Long Frame Sync, Burst Mode

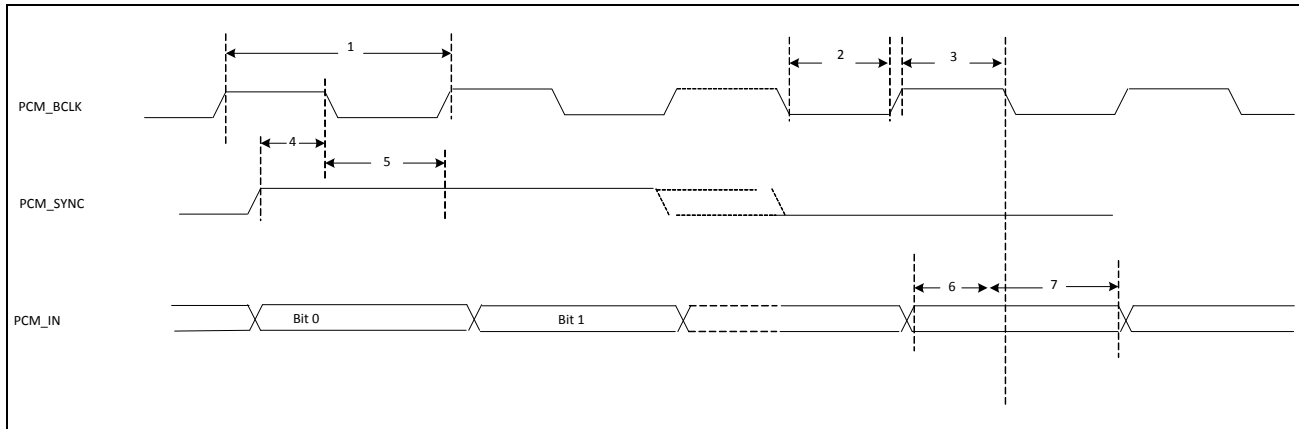

Figure 17: PCM Burst Mode Timing (Receive Only, Long Frame Sync)

Table 10: PCM Burst Mode (Receive Only, Long Frame Sync)

Ref No.	Characteristics	Minimum	Typical	Maximum	Unit
1	PCM bit clock frequency	–	–	24	MHz
2	PCM bit clock HIGH	20.8	–	–	ns
3	PCM bit clock LOW	20.8	–	–	ns
4	PCM_SYNC setup	8	–	–	ns
5	PCM_SYNC hold	8	–	–	ns
6	PCM_IN setup	8	–	–	ns
7	PCM_IN hold	8	–	–	ns

Not Recommended for New Designs

UART Interface

The BCM43241 shares a single UART for Bluetooth and FM. The UART is a standard 4-wire interface (RX, TX, RTS, and CTS) with adjustable baud rates from 9600 bps to 4.0 Mbps. The interface features an automatic baud rate detection capability that returns a baud rate selection. Alternatively, the baud rate may be selected through a vendor-specific UART HCI command.

UART has a 1040-byte receive FIFO and a 1040-byte transmit FIFO to support EDR. Access to the FIFOs is conducted through the AHB interface through either DMA or the CPU. The UART supports the Bluetooth 4.0 UART HCI specification: H4, a custom Extended H4, and H5. The default baud rate is 115.2 Kbaud.

The UART supports the 3-wire H5 UART transport, as described in the Bluetooth specification (“Three-wire UART Transport Layer”). Compared to H4, the H5 UART transport reduces the number of signal lines required by eliminating the CTS and RTS signals.

The BCM43241 UART can perform XON/XOFF flow control and includes hardware support for the Serial Line Input Protocol (SLIP). It can also perform wake-on activity. For example, activity on the RX or CTS inputs can wake the chip from a sleep state.

Normally, the UART baud rate is set by a configuration record downloaded after device reset, or by automatic baud rate detection, and the host does not need to adjust the baud rate. Support for changing the baud rate during normal HCI UART operation is included through a vendor-specific command that allows the host to adjust the contents of the baud rate registers. The BCM43241 UARTs operate correctly with the host UART as long as the combined baud rate error of the two devices is within $\pm 2\%$.

Table 11: Example of Common Baud Rates

<i>Desired Rate</i>	<i>Actual Rate</i>	<i>Error (%)</i>
4000000	4000000	0.00
3692000	3692308	0.01
3000000	3000000	0.00
2000000	2000000	0.00
1500000	1500000	0.00
1444444	1454544	0.70
921600	923077	0.16
460800	461538	0.16
230400	230796	0.17
115200	115385	0.16
57600	57692	0.16
38400	38400	0.00
28800	28846	0.16
19200	19200	0.00
14400	14423	0.16
9600	9600	0.00

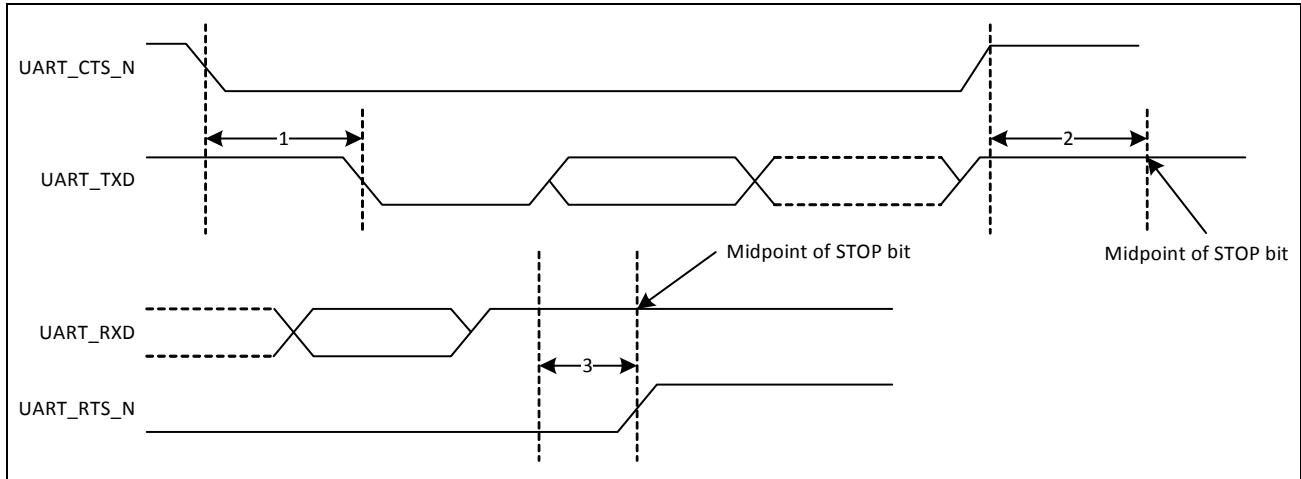

Figure 18: UART Timing

Table 12: UART Timing Specifications

Ref No.	Characteristics	Minimum	Typical	Maximum	Unit
1	Delay time, UART_CTS_N low to UART_TXD valid	–	–	1.5	Bit periods
2	Setup time, UART_CTS_N high before midpoint of stop bit	–	–	0.5	Bit periods
3	Delay time, midpoint of stop bit to UART_RTS_N high	–	–	0.5	Bit periods

Not Recommended for New Designs

I²S Interface

The BCM43241 supports two independent I²S digital audio ports: one for Bluetooth audio, and one for high-fidelity FM audio. The I²S interface for FM audio supports both master and slave modes. The I²S signals are:

- I²S clock: I²S SCK
- I²S Word Select: I²S WS
- I²S Data Out: I²S SDO
- I²S Data In: I²S SDI

I²S SCK and I²S WS become outputs in master mode and inputs in slave mode, while I²S SDO always stays as an output. The channel word length is 16 bits and the data is justified so that the MSB of the left-channel data is aligned with the MSB of the I²S bus, per the I²S specification. The MSB of each data word is transmitted one bit clock cycle after the I²S WS transition, synchronous with the falling edge of bit clock. Left-channel data is transmitted when I²S WS is low, and right-channel data is transmitted when I²S WS is high. Data bits sent by the BCM43241 are synchronized with the falling edge of I2S_SCK and should be sampled by the receiver on the rising edge of I2S_SSCK.

The clock rate in master mode is either of the following:

$$48 \text{ kHz} \times 32 \text{ bits per frame} = 1.536 \text{ MHz}$$

$$48 \text{ kHz} \times 50 \text{ bits per frame} = 2.400 \text{ MHz}$$

The master clock is generated from the input reference clock using a N/M clock divider.

In the slave mode, any clock rate is supported to a maximum of 3.072 MHz.

I²S Timing



Note: Timing values specified in [Table 13](#) are relative to high and low threshold levels.

Table 13: Timing for I²S Transmitters and Receivers

	Transmitter				Receiver				Notes
	Lower Limit		Upper Limit		Lower Limit		Upper Limit		
	Min	Max	Min	Max	Min	Max	Min	Max	
Clock Period T	T_{tr}	–	–	–	T_r	–	–	–	1
Master Mode: Clock generated by transmitter or receiver									
HIGH t_{HC}	$0.35T_{tr}$	–	–	–	$0.35T_{tr}$	–	–	–	2
LOW t_{LC}	$0.35T_{tr}$	–	–	–	$0.35T_{tr}$	–	–	–	2
Slave Mode: Clock accepted by transmitter or receiver									
HIGH t_{HC}	–	$0.35T_{tr}$	–	–	–	$0.35T_{tr}$	–	–	3
LOW t_{LC}	–	$0.35T_{tr}$	–	–	–	$0.35T_{tr}$	–	–	3
Rise time t_{RC}	–	–	$0.15T_{tr}$	–	–	–	–	–	4
Transmitter									
Delay t_{dtr}	–	–	–	$0.8T$	–	–	–	–	5
Hold time t_{htr}	0	–	–	–	–	–	–	–	4
Receiver									
Setup time t_{sr}	–	–	–	–	–	$0.2T_r$	–	–	6
Hold time t_{hr}	–	–	–	–	–	0	–	–	6

**Note:**

- The system clock period T must be greater than T_{tr} and T_r because both the transmitter and receiver have to be able to handle the data transfer rate.
- At all data rates in master mode, the transmitter or receiver generates a clock signal with a fixed mark/space ratio. For this reason, t_{HC} and t_{LC} are specified with respect to T.
- In slave mode, the transmitter and receiver need a clock signal with minimum HIGH and LOW periods so that they can detect the signal. So long as the minimum periods are greater than $0.35T_r$, any clock that meets the requirements can be used.
- Because the delay (t_{dtr}) and the maximum transmitter speed (defined by T_{tr}) are related, a fast transmitter driven by a slow clock edge can result in t_{dtr} not exceeding t_{RC} , which means t_{htr} becomes zero or negative. Therefore, the transmitter has to guarantee that t_{htr} is greater than or equal to zero, so long as the clock rise-time t_{RC} is not more than t_{RCmax} , where t_{RCmax} is not less than $0.15T_{tr}$.
- To allow data to be clocked out on a falling edge, the delay is specified with respect to the rising edge of the clock signal and T, always giving the receiver sufficient setup time.
- The data setup and hold time must not be less than the specified receiver setup and hold time.



Note: The time periods specified in [Figure 19](#) and [Figure 20](#) are defined by the transmitter speed. The receiver specifications must match transmitter performance.

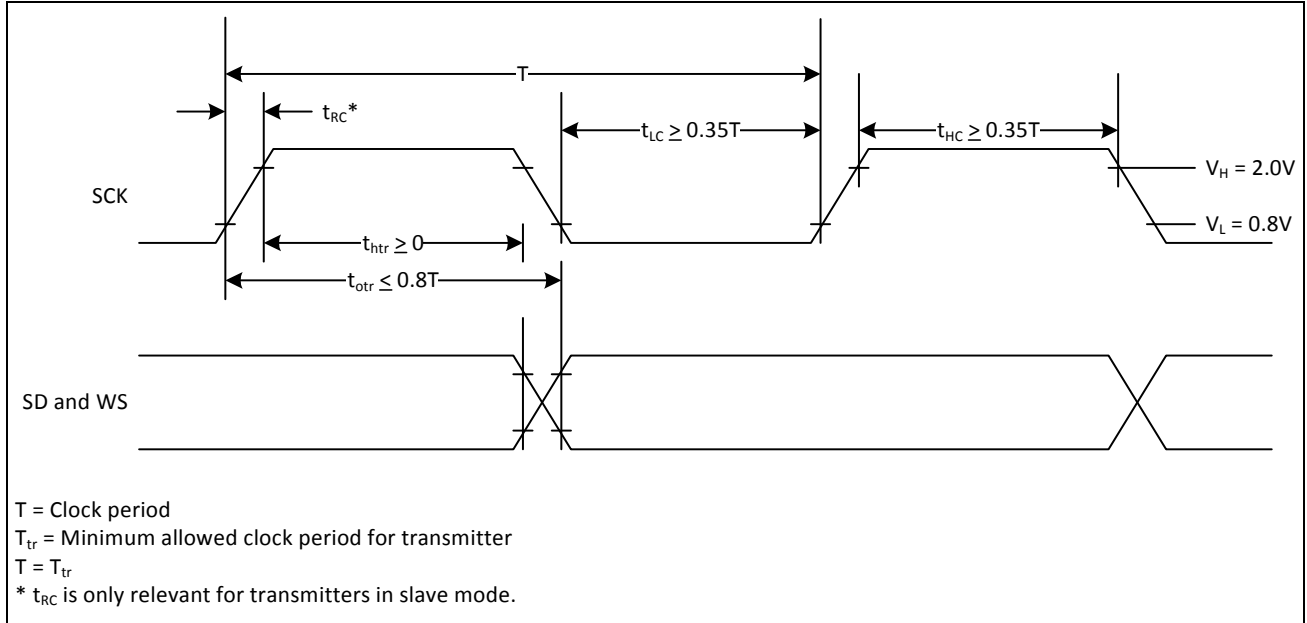

Figure 19: I²S Transmitter Timing

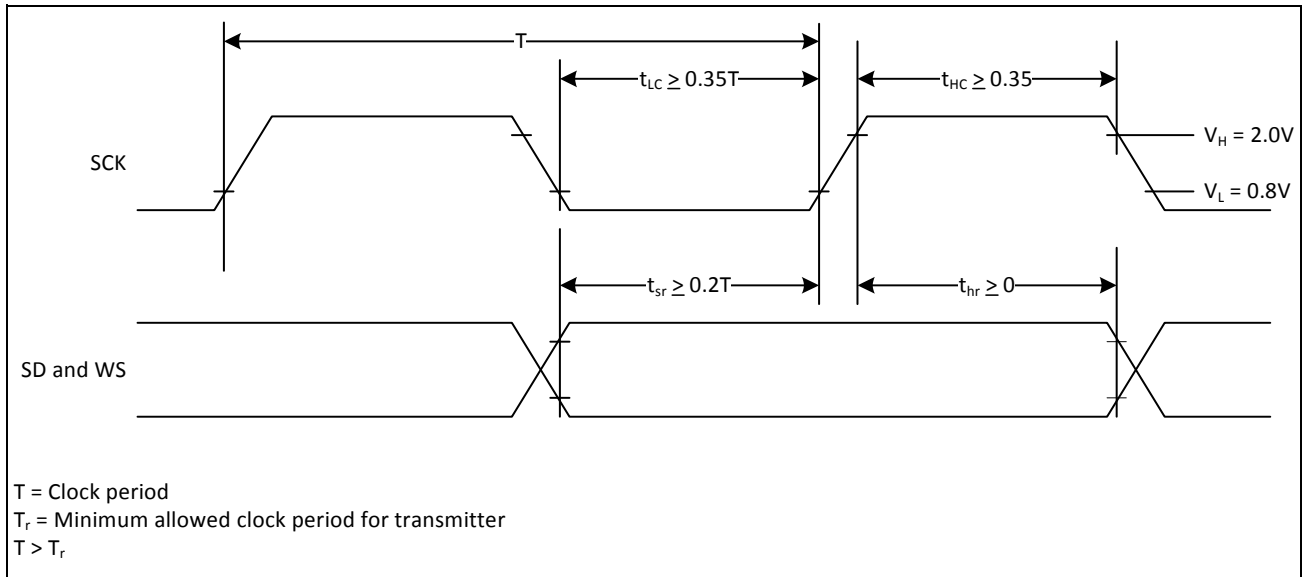

Figure 20: I²S Receiver Timing

Not Recommended for New Designs

Section 9: FM Receiver Subsystem

FM Radio

The BCM43241 includes a completely integrated FM radio receiver with RDS/RBDS covering all FM bands from 65 MHz to 108 MHz. The receiver is controlled through commands on the HCI. FM received audio is available in digital form through I²S or PCM. The FM radio operates from the external clock reference.

Digital FM Audio Interfaces

The FM audio can be transmitted via the shared PCM and I²S pins, and the sampling rate is programmable. The BCM43241 supports a three-wire PCM or I²S audio interface in either master or slave configuration. The master or slave configuration is selected using vendor-specific commands over the HCI interface. In addition, multiple sampling rates are supported, derived from either the FM or Bluetooth clocks. In master mode, the clock rate is either of the following:

- 48 kHz x 32 bits per frame = 1.536 MHz
- 48 kHz x 50 bits per frame = 2.400 MHz

In slave mode, any clock rate is supported up to a maximum of 3.072 MHz.

FM Over Bluetooth

The BCM43241 can output received FM audio onto Bluetooth using one of following three links: eSCO, WBS, and A2DP. In all of the above modes, once the link has been set up, the host processor can enter sleep mode while the BCM43241 continues to stream FM audio to the remote Bluetooth device, allowing the system current consumption to be minimized.

eSCO

In this use case, the stereo FM audio is downsampled to 8 kHz, and a mono or stereo stream is then sent through the Bluetooth eSCO link to a remote Bluetooth device, typically a headset. Two Bluetooth voice connections must be used to transport stereo.

Wideband Speech Link

In this case, the stereo FM audio is downsampled to 16 kHz, and a mono or stereo stream is then sent through the Bluetooth wideband speech link to a remote Bluetooth device, typically a headset. Two Bluetooth voice connections must be used to transport stereo.

A2DP

In this case, the stereo FM audio is encoded by the on-chip SBC encoder and transported as an A2DP link to a remote Bluetooth device. Sampling rates of 48 kHz, 44.1 kHz, and 32 kHz joint stereo are supported. An A2DP 'lite' stack is implemented in the BCM43241 to support this use case, which eliminates the need to route the SBC-encoded audio back to the host to create the A2DP packets.

Autotune and Search Algorithms

The BCM43241 supports a number of FM search and tune functions. This allows the host to implement many convenient user functions, which are accessed through the Broadcom FM stack.

- Tune to Play— Allows the FM receiver to be programmed to a specific frequency.
- Search for SNR > Threshold— Checks the power level of the available channel and the estimated SNR of the channel to help achieve precise control of the expected sound quality for the selected FM channel. Specifically, the host can adjust its SNR requirements to retrieve a signal with a specific sound quality or adjust this to return the weakest channels.
- Alternate Frequency Jump— Allows the FM receiver to automatically jump to an alternate FM channel that carries the same information, but has a better SNR. For example, when traveling, a user may pass through a region where a number of channels carry the same station. When the user passes from one area to the next, the FM receiver can automatically switch to another channel with a stronger signal to spare the user from having to manually change the channel to continue listening to the same station.

Audio Features

A number of features are implemented in the BCM43241 to provide the best possible audio experience for the user.

- Mono/Stereo Blend or Switch: The BCM43241 provides automatic control of the stereo or mono settings based on the FM signal carrier-to-noise ratio (C/N). This feature is used to maintain the best possible audio SNR based on the FM channel condition. Two modes of operation are supported:
 - Blend: In this mode, fine control of stereo separation is used to achieve optimal audio quality over a wide range of input C/N. The amount of separation is fully programmable. In [Figure 21](#), the separation is programmed to maintain a minimum 50 dB SNR across the blend range.
 - Switch: In this mode, the audio switches from full stereo to full mono at a predetermined level to

maintain optimal audio quality. The stereo-to-mono switch point and the mono-to-stereo switch point are fully programmable to provide the desired amount of audio SNR. In Figure 22, the switch point is programmed to switch to mono to maintain a 40 dB SNR.

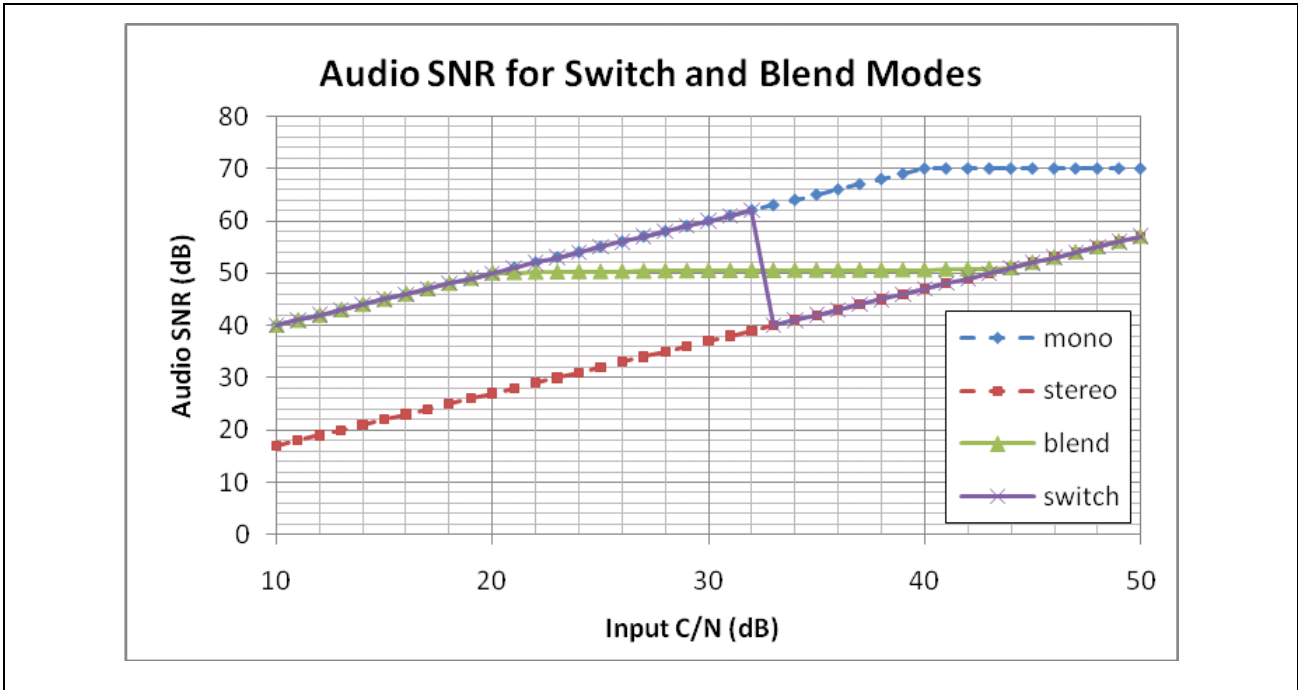

Figure 21: Example Blend/Switch Usage

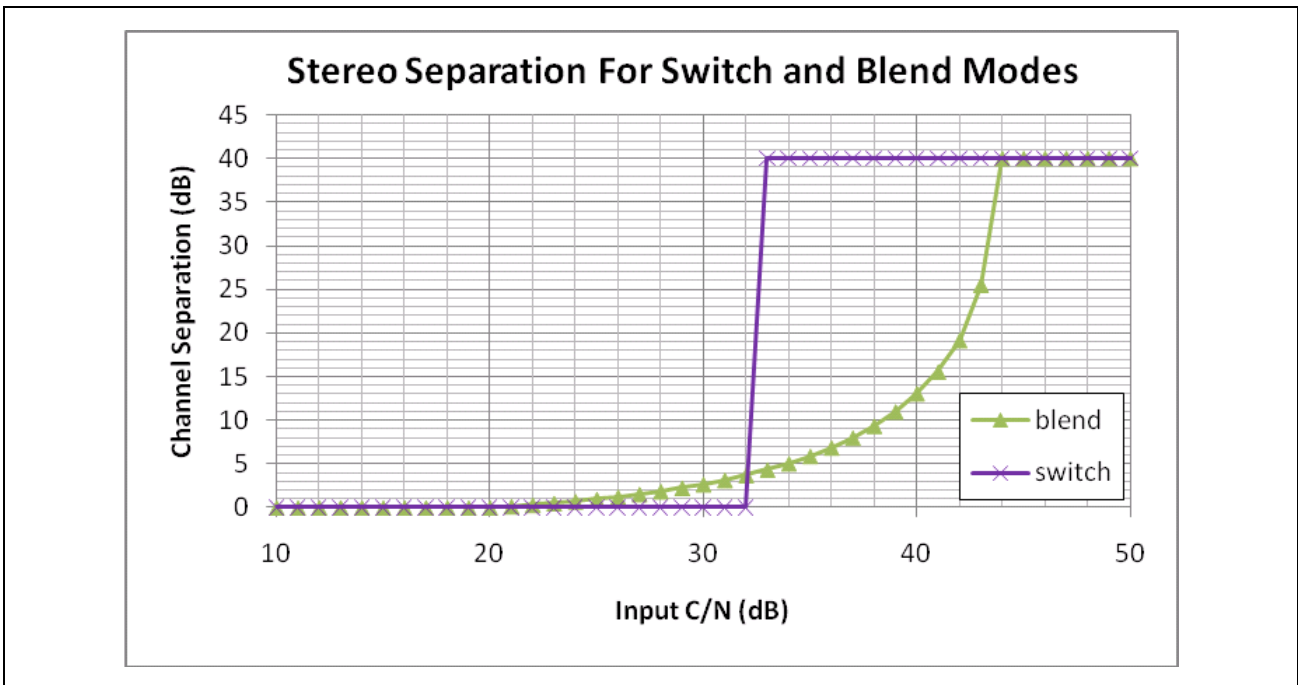

Figure 22: Example Blend/Switch Separation

Not Recommended for New Designs

- **Soft Mute:** Improves the user experience by dynamically muting the output audio proportionate to the FM signal C/N. This prevents the user from being assaulted with a blast of static. The mute characteristic is fully programmable to accommodate fine-tuning of the output signal level. An example mute characteristic is shown in [Figure 23](#).

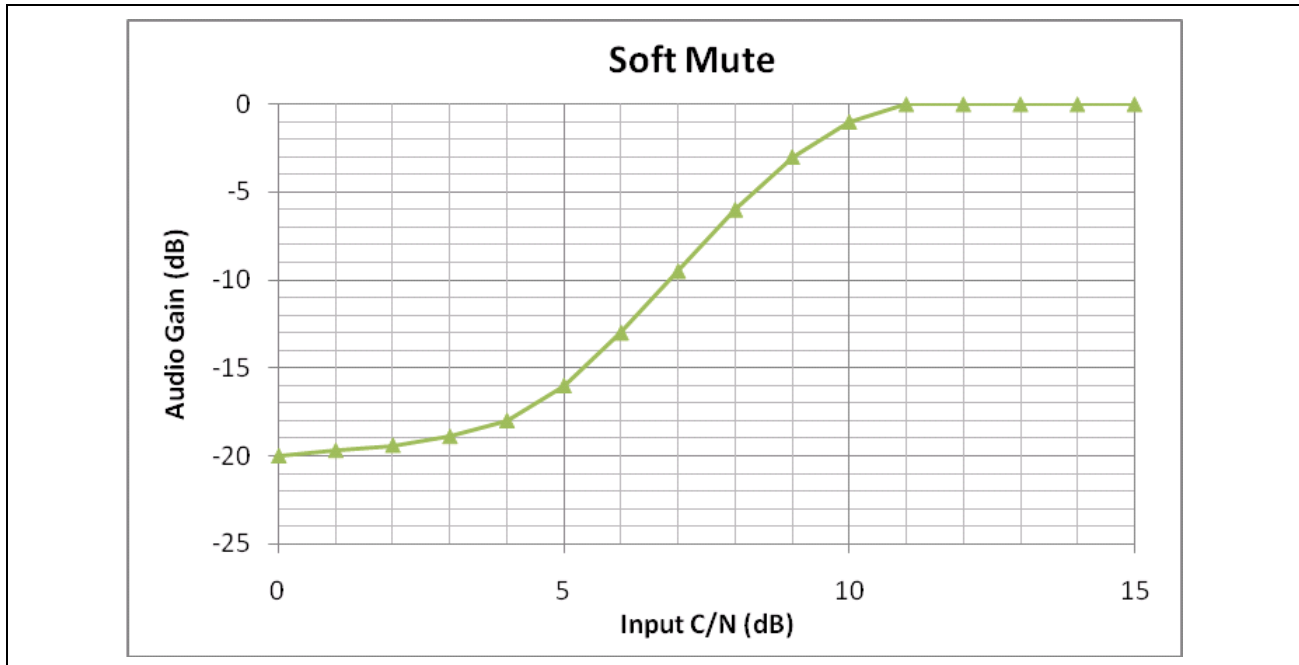

Figure 23: Example Soft Mute Characteristic

- **High Cut:** A programmable high-cut filter is provided to reduce the amount of high-frequency noise caused by static in the output audio signal. Like the soft mute circuit, it is fully programmable to allow for any amount of high cut based on the FM signal C/N.
- **Audio Pause Detect:** The FM receiver monitors the magnitude of the audio signal and notifies the host through an interrupt when the magnitude of the signal has fallen below the threshold set for a programmable period. This feature can be used to provide alternate frequency jumps during periods of silence to minimize disturbances to the listener. Filtering techniques are used within the audio pause detection block to provide more robust presence-to-silence detection and silence-to-presence detection.
- **Automatic Antenna Tuning:** The BCM43241 has an on-chip automatic antenna tuning network. When used with a single off-chip inductor, the on-chip circuitry automatically chooses an optimal on-chip matching component to obtain the highest signal strength for the desired frequency. The high-Q nature of this matching network simultaneously provides out-of-band blocking protection as well as a reduction of radiated spurious emissions from the FM antenna. It is designed to accommodate a wide range of external wire antennas.

On-Chip MP3 Encoding

In this mode of operation, the device can record the FM audio to MP3, then output the MP3 data over the HCI interface. The feature effectively offloads the MP3 recording processing load from the host and assists in FM time shift applications. This feature can also be used in conjunction with burst mode buffering to provide significant FM system record times.

RDS/RBDS

The BCM43241 integrates an RDS/RBDS modem and decoder. The decoder includes programmable filtering and buffering functions. The RDS/RBDS data can be read out through the HCI interface.

Supported RDS/RBDS functionality includes:

- Block decoding, error correction, and synchronization
- Flywheel synchronization feature allows the host to set parameters for acquisition, maintenance, and loss of sync. (It is possible to set up the BCM43241 such that synch is achieved when a minimum of two good blocks (error-free) are decoded in sequence. The number of good blocks required for sync is programmable.)
- Storage capability up to 126 blocks of RDS data
- Full or partial block B match detect and interrupt to host
- Audio pause detection with programmable parameters
- Program Identification (PI) code detection and interrupt to host
- Automatic frequency jump

Section 10: WLAN Global Functions

WLAN CPU and Memory Subsystem

The BCM43241 includes an integrated ARM Cortex-M3™ processor with internal RAM and ROM. The ARM Cortex-M3 processor is a low-power processor that features low gate count, low interrupt latency, and low-cost debug. It is intended for deeply embedded applications that require fast interrupt response features. The processor implements the ARM architecture v7-M with support for Thumb®-2 instruction set. ARM Cortex-M3 delivers 30% more performance gain over ARM7TDMI.

At 0.19 $\mu\text{W}/\text{MHz}$, the Cortex-M3 is the most power-efficient general-purpose microprocessor available, outperforming 8- and 16-bit devices on MIPS/ μW . It supports integrated sleep modes.

ARM Cortex-M3 uses multiple technologies to reduce cost through improved memory utilization, reduced pin overhead, and reduced silicon area. ARM Cortex-M3 supports independent buses for Code and Data access (ICode/DCode and System buses). ARM Cortex-M3 supports extensive debug features including real time trace of program execution.

On-chip memory for the CPU includes 576 KB RAM and 640 KB ROM.

One-Time Programmable Memory

Various hardware configuration parameters may be stored in an internal 3072-bit One-Time Programmable (OTP) memory, which is read by the system software after device reset. In addition, customer-specific parameters including the system vendor ID and the MAC address can be stored, depending on the specific board design.

The initial state of all bits in an unprogrammed OTP device is 0. After any bit is programmed to a 1, it cannot be reprogrammed to 0. The entire OTP array can be programmed in a single write cycle using a utility provided with the Broadcom WLAN manufacturing test tools. Alternatively, multiple write cycles can be used to selectively program specific bytes, but only bits which are still in the 0 state can be altered during each programming cycle.

Prior to OTP programming, all values should be verified using the appropriate editable nvram.txt file, which is provided with the reference board design package.

GPIO Interface

The BCM43241 has 16 general-purpose I/O (GPIO) that can be used to connect to various external devices.

Upon power-up and reset, these pins become tristated. Subsequently, they can be programmed to be either input or output pins via the GPIO control register. An internal (programmable) pull-up/pull-down resistor is included on each GPIO.

External Coexistence Interface

An external handshake interface is available to enable signaling between the device and an external colocated wireless device, such as GPS, WiMAX, or UWB, to manage wireless medium sharing for optimum performance. The following signals can be enabled by software on the indicated WL_GPIO pins:

- ERCX_STATUS WL_GPIO2
- ERCX_FREQ WL_GPIO3
- ERCX_RF_ACTIVE WL_GPIO4
- ERCX_TXCONF WL_GPIO5
- ERCX_PRISEL WL_GPIO12

UART Interface

One UART interface can be enabled by software as an alternate function on pins WL_GPIO_14 and WL_GPIO_15. Provided primarily for debugging during development, this UART enables the BCM43241 to operate as RS-232 data termination equipment (DTE) for exchanging and managing data with other serial devices. It is compatible with the industry standard 16550 UART, and it provides a FIFO size of 64 × 8 in each direction.

JTAG Interface

The BCM43241 supports the IEEE 1149.1 JTAG boundary scan standard for performing device package and PCB assembly testing during manufacturing. In addition, the JTAG interface allows Broadcom to assist customers by using proprietary debug and characterization test tools during board bring-up. Therefore, it is highly recommended to provide access to the JTAG pins by means of test points or a header on all PCB designs.

The JTAG interface (multiplexed on the GPIO pins) is enabled when the JTAG_SEL pin is asserted high.

Section 11: WLAN Host Interfaces

SDIO v3.0

The BCM43241 WLAN section supports SDIO version 3.0 for all 1.8V 4-bit UHSI speeds: SDR50 (100 MHz), SDR104 (208 MHz) and DDR50 (50 MHz, dual data rates) in addition to the 3.3V default speed (25 MHz) and high speed (50 MHz). For the exact BCM43241 SDIO timings, see [Section 21: “Interface Timing and AC Characteristics,”](#) on page 148.

The BCM43241 has the ability to map the interrupt signal onto a GPIO pin. This out-of-band interrupt signal notifies the host when the WLAN device wants to turn on the SDIO interface. The ability to force control of the gated clocks from within the WLAN chip is also provided.

The BCM43241 supports the new SDIO 3.0 cmd11 to switch from 3.3V signaling to 1.8V signaling.

SDIO mode is enabled using the strapping option pins strap_host_ifc_[3:1] ([Table 20: “WLAN GPIO Functions and Strapping Options \(Advance Information\),”](#) on page 100).

Three functions are supported:

- Function 0 Standard SDIO function (Max BlockSize/ByteCount = 32B)
- Function 1 Backplane Function to access the internal system-on-chip (SoC) address space (Max BlockSize/ByteCount = 64B)
- Function 2 WLAN Function for efficient WLAN packet transfer through DMA (Max BlockSize/ByteCount = 512B)

SDIO Pin Descriptions

Table 14: SDIO Pin Description

<i>SD 4-Bit Mode</i>		<i>SD 1-Bit Mode</i>		<i>gSPI Mode</i>	
DATA0	Data line 0	DATA	Data line	DO	Data output
DATA1	Data line 1 or Interrupt	IRQ	Interrupt	IRQ	Interrupt
DATA2	Data line 2 or Read Wait	RW	Read Wait	NC	Not used
DATA3	Data line 3	N/C	Not used	CS	Card select
CLK	Clock	CLK	Clock	SCLK	Clock
CMD	Command line	CMD	Command line	DI	Data input

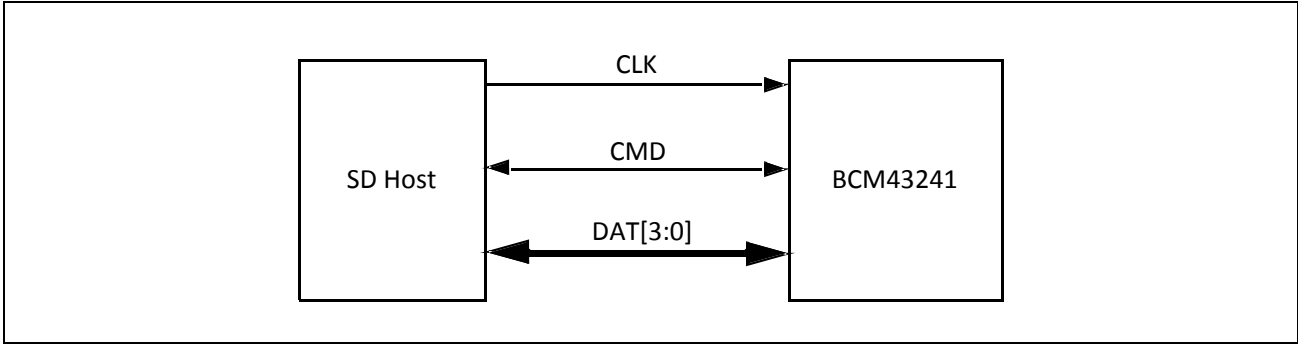

Figure 24: Signal Connections to SDIO Host (SD 4-Bit Mode)

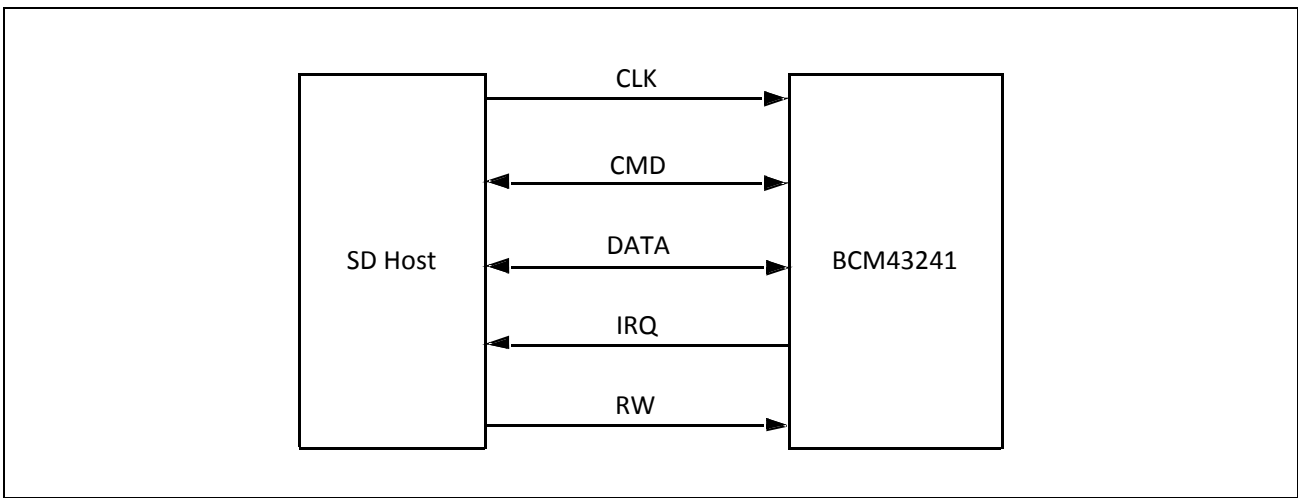

Figure 25: Signal Connections to SDIO Host (SD 1-Bit Mode)

Not Recommended for New Designs

Generic SPI Mode

In addition to the full SDIO mode, the BCM43241 includes the option of using the simplified generic SPI (gSPI) interface/protocol. Characteristics of the gSPI mode include:

- Supports up to 48 MHz operation
- Supports fixed delays for responses and data from device
- Supports alignment to host gSPI frames (16 or 32 bits)
- Supports up to 2 KB frame size per transfer
- Supports little endian and big endian configurations
- Supports configurable active edge for shifting
- Supports packet transfer through DMA for WLAN

gSPI mode is enabled using the strapping option pins strap_host_ifc_[3:1], [Table 20: “WLAN GPIO Functions and Strapping Options \(Advance Information\),”](#) on page 100.

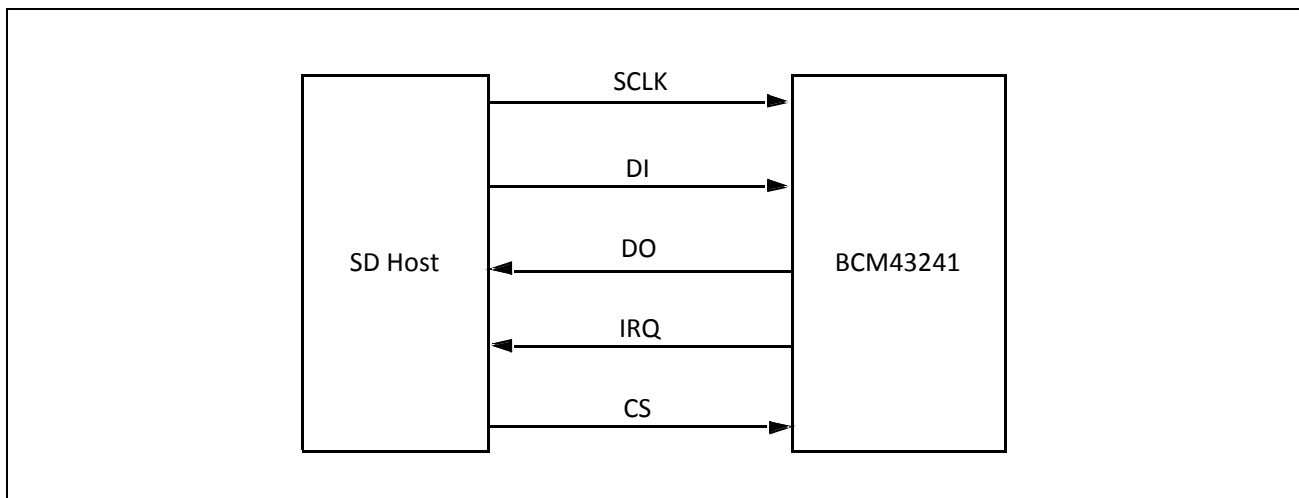

Figure 26: Signal Connections to SDIO Host (gSPI Mode)

SPI Protocol

The SPI protocol supports both 16-bit and 32-bit word operation. Byte endianness is supported in both modes. Figure 27 and Figure 28 show the basic write and write/read commands.

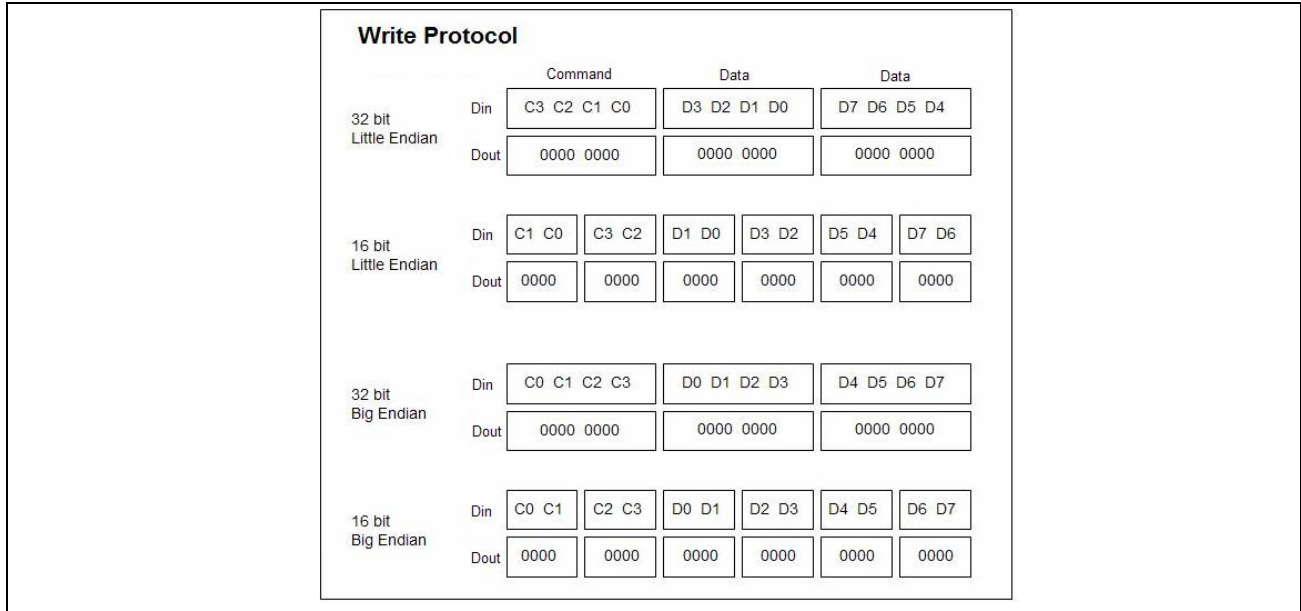

Figure 27: gSPI Write Protocol

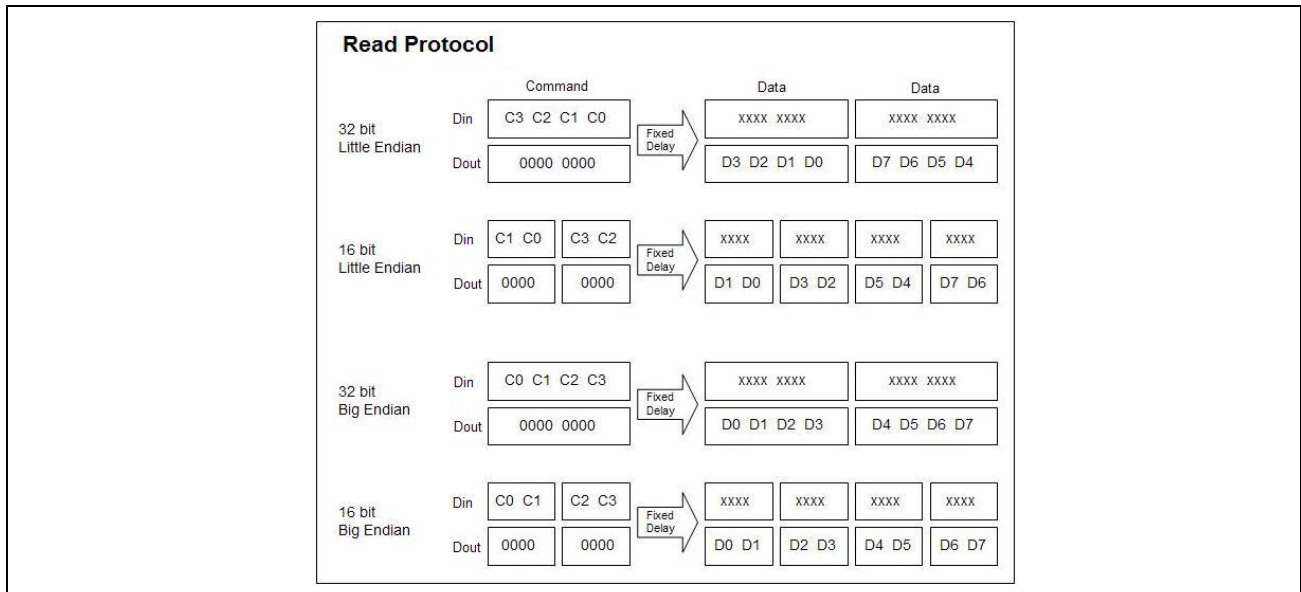

Figure 28: gSPI Read Protocol

Not Recommended for New Designs

Command Structure

The gSPI command structure is 32 bits. The bit positions and definitions are shown in [Figure 29](#).

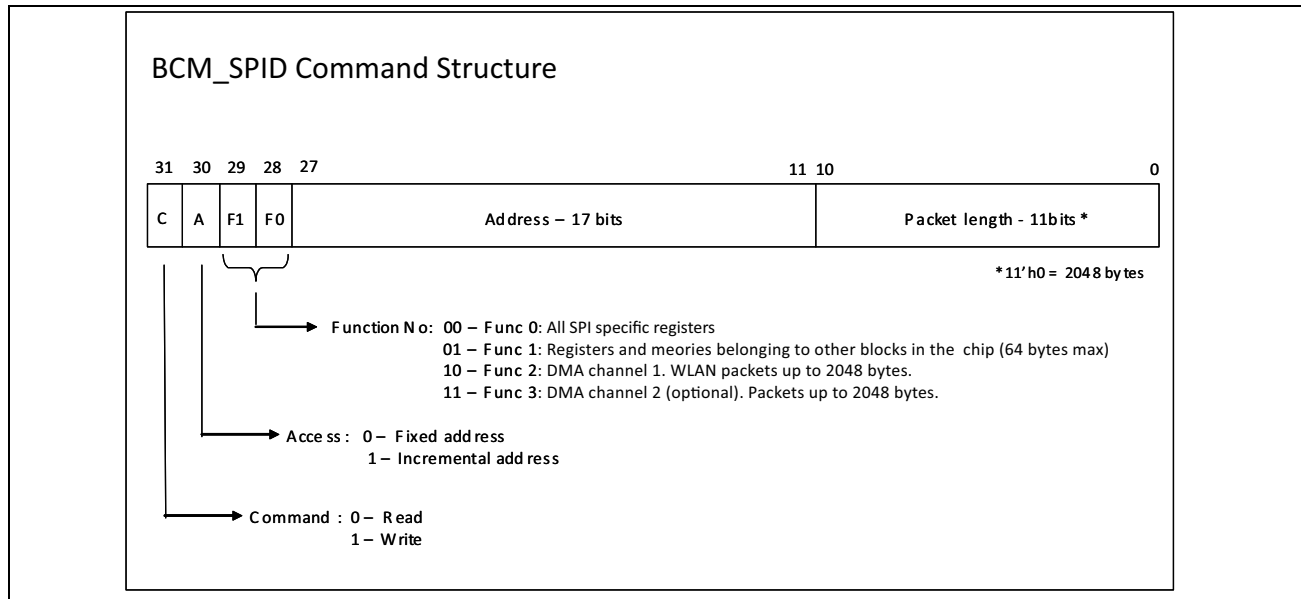

Figure 29: gSPI Command Structure

Write

The host puts the first bit of the data onto the bus half a clock-cycle before the first active edge following the CS going low. The following bits are clocked out on the falling edge of the gSPI clock. The device samples the data on the active edge.

Write/Read

The host reads on the rising edge of the clock requiring data from the device to be made available before the first rising clock edge of the clock burst for the data. The last clock edge of the fixed delay word can be used to represent the first bit of the following data word. This allows data to be ready for the first clock edge without relying on asynchronous delays.

Read

The read command always follows a separate write to set up the WLAN device for a read. This command differs from the write/read command in the following respects: a) chip selects go high between the command/address and the data and b) the time interval between the command/address is not fixed.

Not Recommended for New Designs

Status

The gSPI interface supports status notification to the host after a read/write transaction. This status notification provides information about any packet errors, protocol errors, information about available packet in the RX queue, etc. The status information helps in reducing the number of interrupts to the host. The status-reporting feature can be switched off using a register bit, without any timing overhead. The gSPI bus timing for read/write transactions with and without status notification is shown in Figure 30 and Figure 31 on page 74. See Table 15 on page 74 for information on status field details.

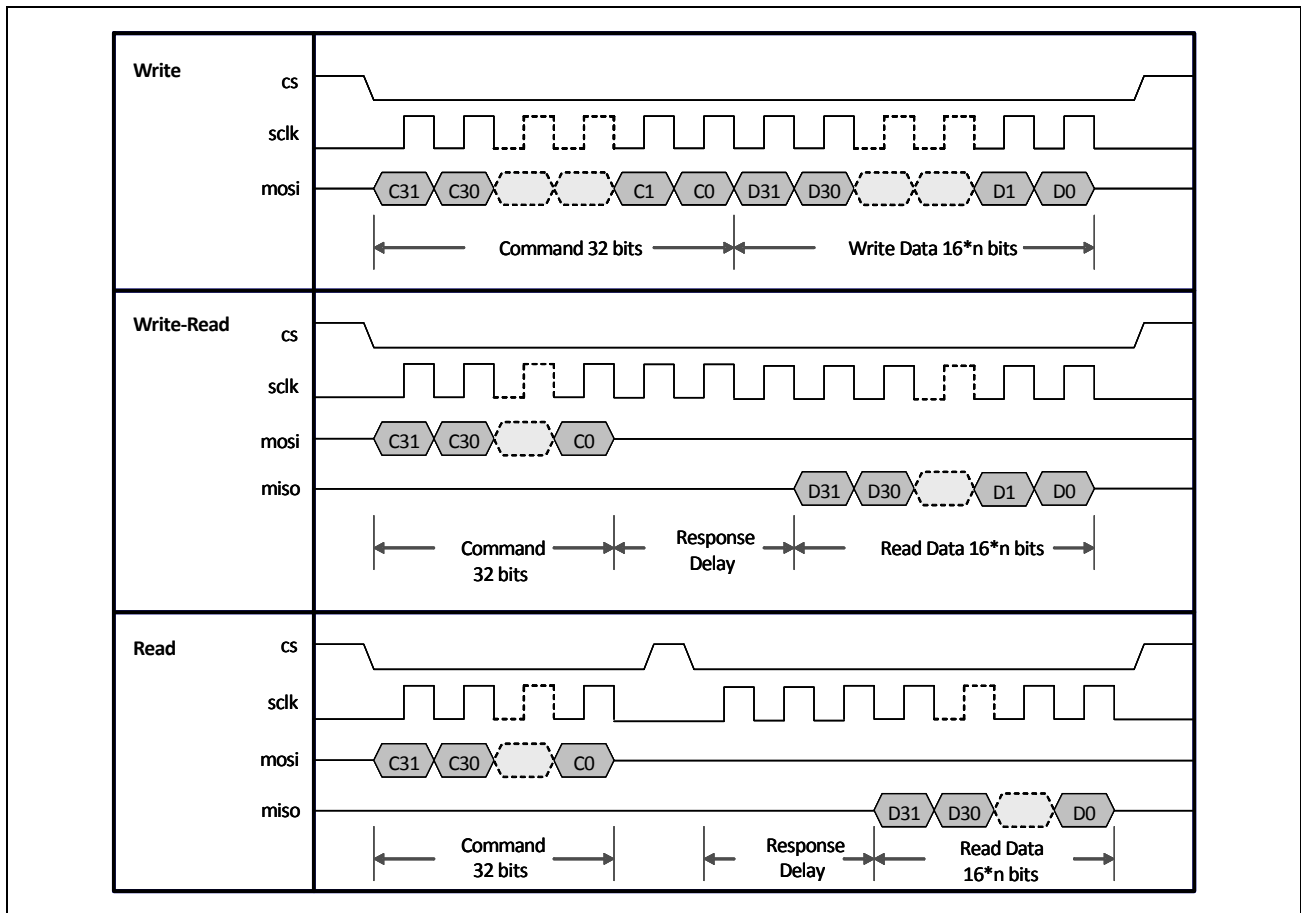

Figure 30: gSPI Signal Timing Without Status

Not Recommended for New Designs

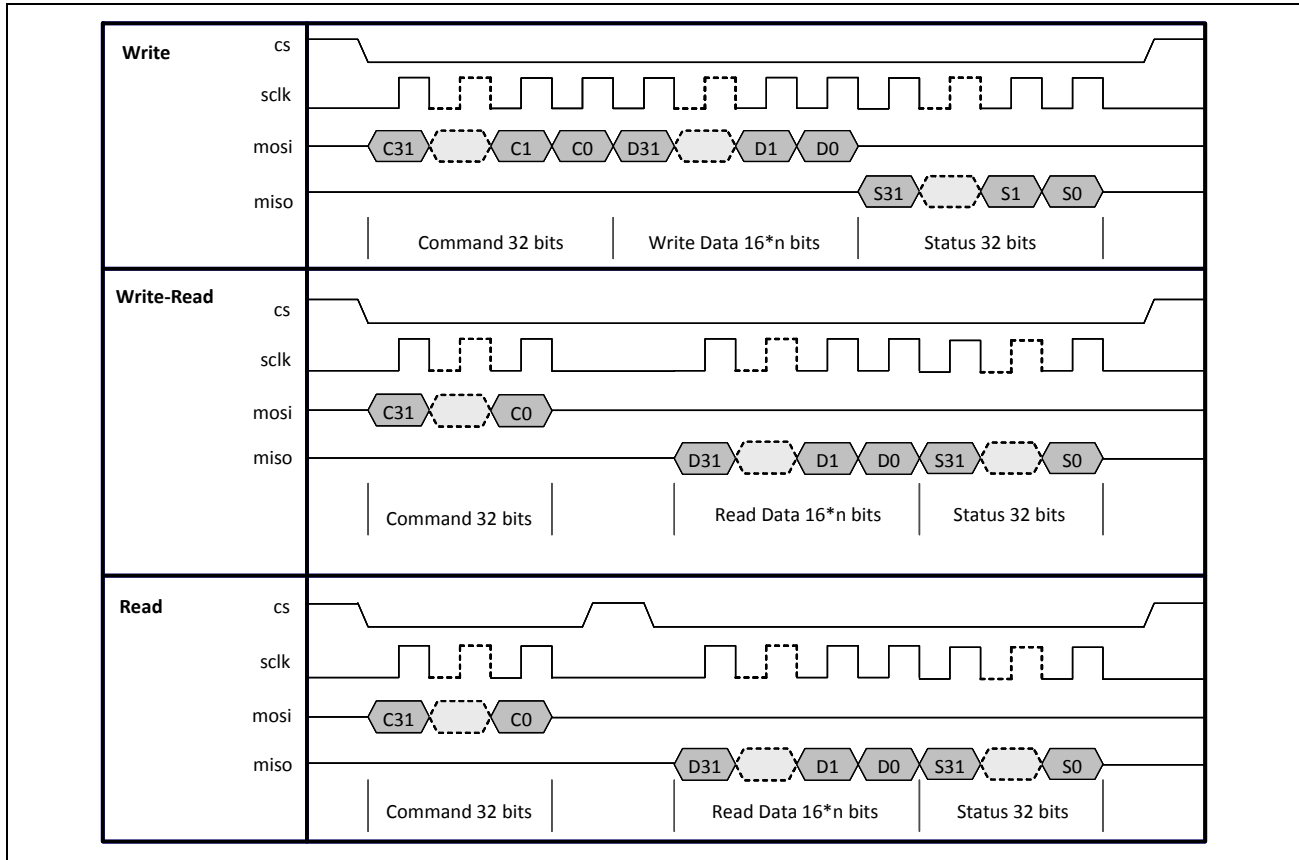

Figure 31: gSPI Signal Timing with Status (Response Delay = 0)

Table 15: gSPI Status Field Details

Bit	Name	Description
0	Data not available	The requested read data is not available.
1	Underflow	FIFO underflow occurred due to current (F2, F3) read command
2	Overflow	FIFO overflow occurred due to current (F1, F2, F3) write command
3	F2 interrupt	F2 channel interrupt
4	F3 interrupt	F3 channel interrupt
5	F2 RX Ready	F2 FIFO is ready to receive data (FIFO empty)
6	F3 RX Ready	F3 FIFO is ready to receive data (FIFO empty)
7	Reserved	–
8	F2 Packet Available	Packet is available/ready in F2 TX FIFO
9:19	F2 Packet Length	Length of packet available in F2 FIFO
20	F3 Packet Available	Packet is available/ready in F3 TX FIFO
21:31	F3 Packet Length	Length of packet available in F3 FIFO

Not Recommended for New Designs

gSPI Host-Device Handshake

To initiate communication through the gSPI after power-up, the host needs to bring up the WLAN/Chip by writing to the wake-up WLAN register bit. Writing a 1 to this bit will start up the necessary crystals and PLLs so that the BCM43241 is ready for data transfer. The device can signal an interrupt to the host indicating that the device is awake and ready. This procedure also needs to be followed for waking up the device in sleep mode. The device can interrupt the host using the WLAN IRQ line whenever it has any information to pass to the host. On getting an interrupt, the host needs to read the interrupt and/or status register to determine the cause of interrupt and then take necessary actions.

Bootup Sequence

After power-up, the gSPI host needs to wait 150 ms for the device to be out of reset. For this, the host needs to poll with a read command to F0 addr 0x14. Address 0x14 contains a predefined bit pattern. As soon as the host gets a response back with the correct register content, it implies that the device has powered up and is out of reset. After that, the host needs to set the wake-up WLAN bit (F0 reg 0x00 bit 7). The wake-up WLAN issues a clock request to the PMU.

For the first time after power-up, the host must wait for the availability of low-power clock inside the device. Once that is available, the host must write to a PMU register to set the crystal frequency, which turns on the PLL. After the PLL is locked, the chipActive interrupt is issued to the host. This interrupt indicates the device awake/ready status. See [Table 16](#) for information on gSPI registers.

In [Table 16](#), the following notation is used for register access:

- R: Readable from host and CPU
- W: Writable from host
- U: Writable from CPU

Table 16: gSPI Registers

Address	Register	Bit	Access	Default	Description
x0000	Word length	0	R/W/U	0	0: 16-bit word length 1: 32-bit word length
	Endianness	1	R/W/U	0	0: Little Endian 1: Big Endian
	High-speed mode	4	R/W/U	1	0: Normal mode. RX and TX at different edges. 1: High speed mode. RX and TX on same edge (default).
	Interrupt polarity	5	R/W/U	1	0: Interrupt active polarity is low. 1: Interrupt active polarity is high (default).
	Wake-up	7	R/W	0	A write of 1 will denote a wake-up command from the host to the device. This will be followed by an F2 Interrupt from the gSPI device to the host, indicating device awake status.
x0001	Response delay	7:0	R/W/U	8'h04	Configurable read response delay in multiples of 8 bits.

Table 16: gSPI Registers (Cont.)

Address	Register	Bit	Access	Default	Description
x0002	Status enable	0	R/W	1	0: no status sent to host after read/write 1: status sent to host after read/write
	Interrupt with status	1	R/W	0	0: do not interrupt if status is sent 1: interrupt host even if status is sent
	Response delay for all	2	R/W	0	0: response delay applicable to F1 read only 1: response delay applicable to all function read
x0003	Reserved	–	–	–	–
x0004	Interrupt register	0	R/W	0	Requested data not available; cleared by writing a 1 to this location
		1	R	0	F2/F3 FIFO underflow due to last read
		2	R	0	F2/F3 FIFO overflow due to last write
		5	R	0	F2 packet available
		6	R	0	F3 packet available
		7	R	0	F1 overflow due to last write
		x0005	Interrupt register	5	R
6	R			0	F2 Interrupt
7	R			0	F3 Interrupt
x0006– x0007	Interrupt enable register	15:0	R/W/U	16'hE0E7	Particular Interrupt is enabled if a corresponding bit is set
x0008– x000B	Status register	31:0	R	32'h0000	Same as status bit definitions
x000C– x000D	F1 info register	0	R	1	F1 enabled
		1	R	0	F1 ready for data transfer
		13:2	R/U	12'h40	F1 max packet size
x000E– x000F	F2 info register	0	R/U	1	F2 enabled
		1	R	0	F2 ready for data transfer
		15:2	R/U	14'h800	F2 max packet size
x0010– x0011	F3 info register	0	R/U	1	F3 enabled
		1	R	0	F3 ready for data transfer
		15:2	R/U	14'h800	F3 max packet size
x0014– x0017	Test–Read only register	31:0	R	32'hFEED BEAD	This register contains a predefined pattern, which the host can read and determine if the gSPI interface is working properly.
x0018– x001B	Test–R/W register	31:0	R/W/U	32'h0000 0000	This is a dummy register where the host can write some pattern and read it back to determine if the gSPI interface is working properly.

Figure 32 shows the WLAN bootup sequence from power-up to firmware download.

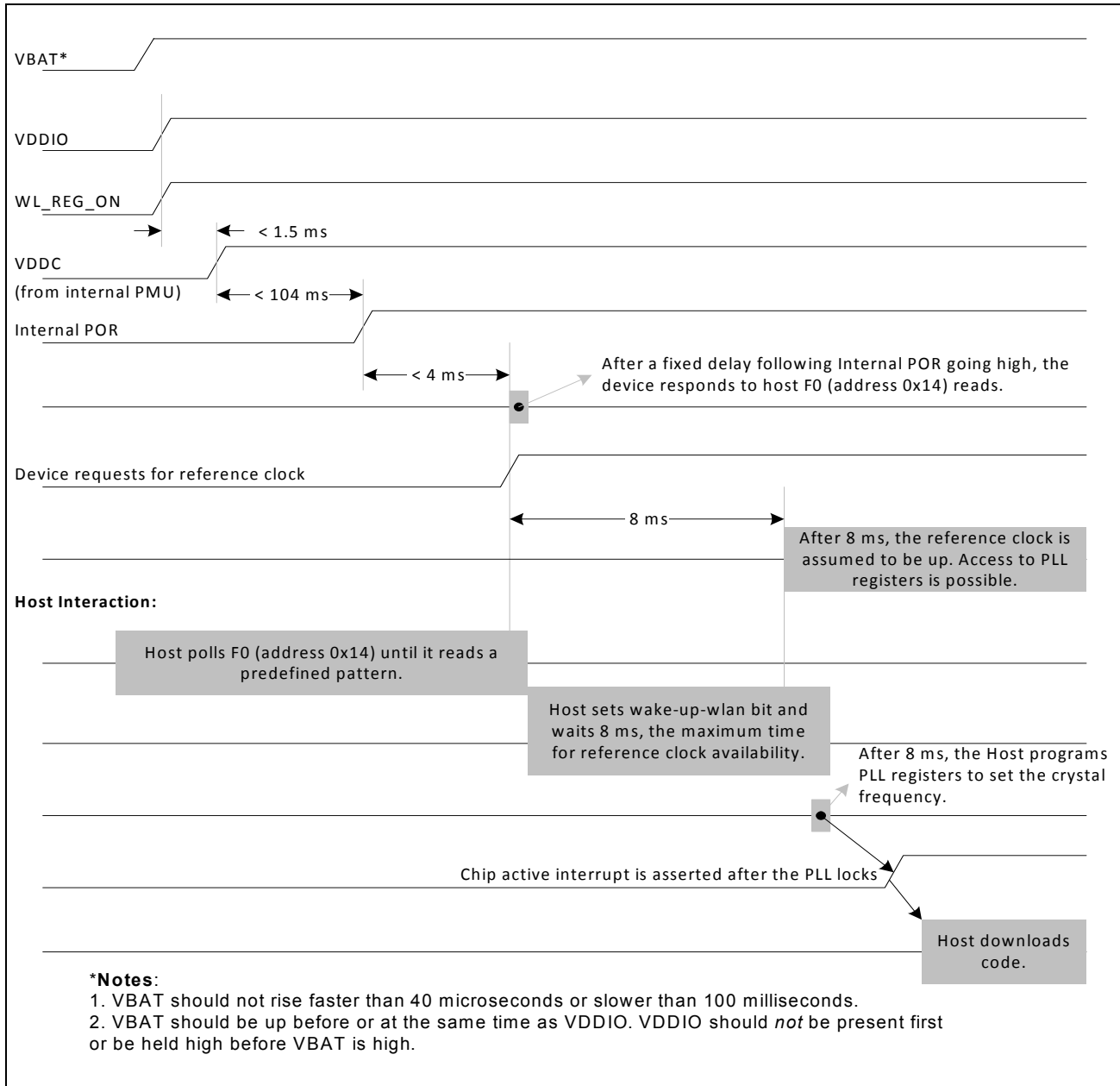

Figure 32: WLAN Bootup Sequence

Not Recommended for New Designs

HSIC Interface

As an alternative to SDIO, an HSIC host interface can be enabled using the strapping option pins strap_host_ifc_[3:1] (Table 20: “WLAN GPIO Functions and Strapping Options (Advance Information),” on page 100). HSIC is a simplified derivative of the USB2.0 interface designed to replace a standard USB PHY and cable for short distances (up to 10 cm) on board point-to-point connections. Using two signals, a bidirectional data strobe (STROBE) and a bidirectional DDR data signal (DATA), it provides high-speed serial 480 Mbps USB transfers that are 100% host driver compatible with traditional USB 2.0 cable-connected topologies.

Figure 33 shows the blocks in the HSIC device core.

Key features of HSIC include:

- High-speed 480 Mbps data rate only
- Source-synchronous serial interface using 1.2V LVCMOS signal levels
- No power consumed except when a data transfer is in progress
- Maximum trace length of 10 cm
- No Plug-n-Play support, no hot attach/removal

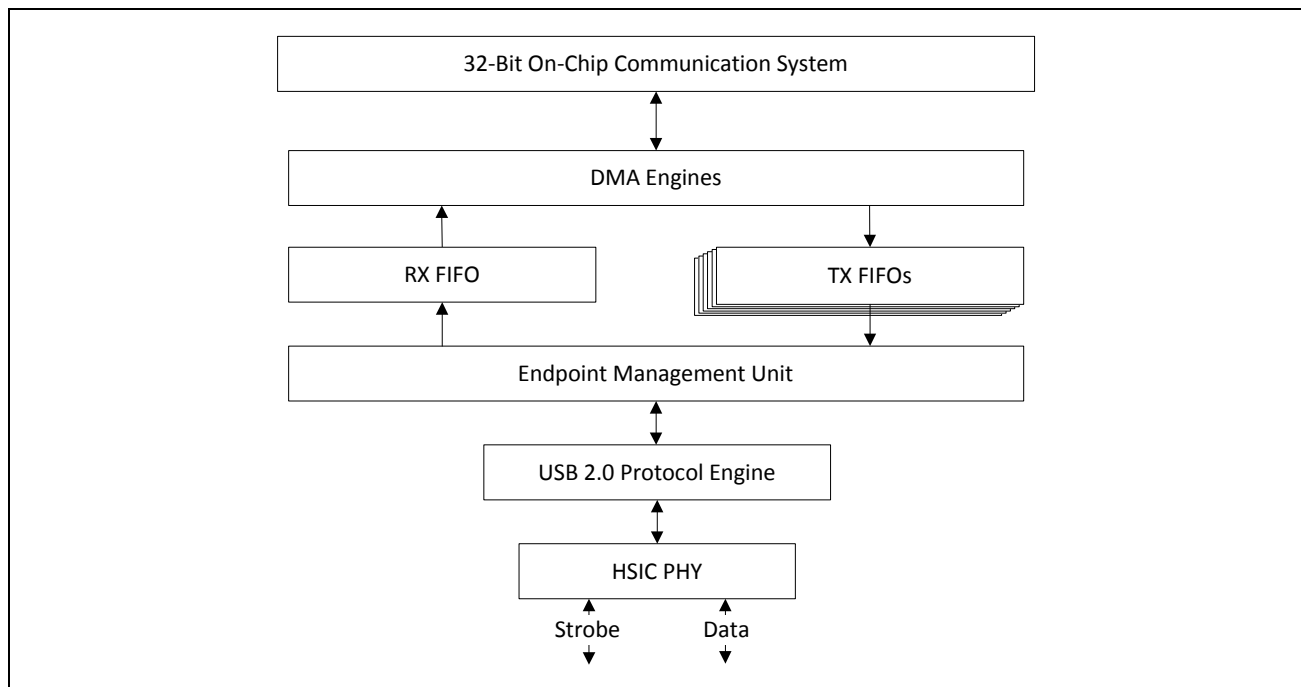

Figure 33: HSIC Device Block Diagram

Not Recommended for New Designs

Section 12: Wireless LAN MAC and PHY

MAC Features

The BCM43241 WLAN media access controller (MAC) supports features specified in the IEEE 802.11 base standard, and amended by IEEE 802.11n. The salient features are listed below:

- Transmission and reception of aggregated MPDUs (A-MPDU)
- Support for power management schemes, including WMM power-save, power-save multipoll (PSMP) and multiphase PSMP operation
- Support for immediate ACK and Block-ACK policies
- Interframe space timing support, including RIFS
- Support for RTS/CTS and CTS-to-self frame sequences for protecting frame exchanges
- Back-off counters in hardware for supporting multiple priorities as specified in the WMM specification
- Timing synchronization function (TSF), network allocation vector (NAV) maintenance, and target beacon transmission time (TBTT) generation in hardware
- Hardware offload for AES-CCMP, legacy WPA TKIP, legacy WEP ciphers, WAPI, and support for key management
- Support for coexistence with Bluetooth and other external radios
- Programmable independent basic service set (IBSS) or infrastructure basic service set functionality
- Statistics counters for MIB support

MAC Description

The BCM43241 WLAN MAC is designed to support high-throughput operation with low-power consumption. It does so without compromising the Bluetooth coexistence policies, thereby enabling optimal performance over both networks. In addition, several power saving modes have been implemented that allow the MAC to consume very little power while maintaining network-wide timing synchronization. The architecture diagram of the MAC is shown in [Figure 34 on page 80](#).

The following sections provide an overview of the important modules in the MAC.

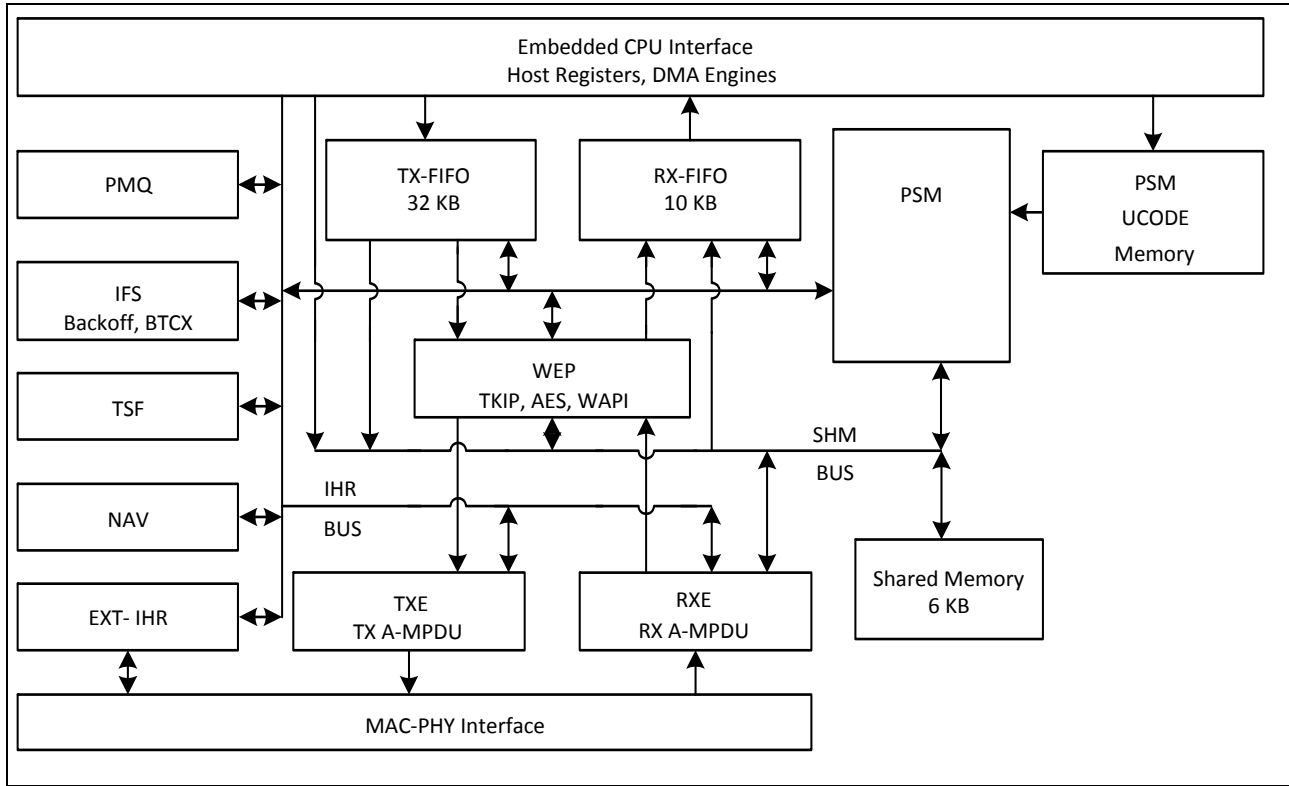

Figure 34: WLAN MAC Architecture

PSM

The programmable state machine (PSM) is a microcoded engine, which provides most of the low-level control to the hardware, to implement the IEEE 802.11 specification. It is a microcontroller that is highly optimized for flow control operations, which are predominant in implementations of communication protocols. The instruction set and fundamental operations are simple and general, which allows algorithms to be optimized until very late in the design process. It also allows for changes to the algorithms to track evolving IEEE 802.11 specifications.

The PSM fetches instructions from the microcode memory. It uses the shared memory to obtain operands for instructions, as a data store, and to exchange data between both the host and the MAC data pipeline (via the SHM bus). The PSM also uses a scratchpad memory (similar to a register bank) to store frequently accessed and temporary variables.

The PSM exercises fine-grained control over the hardware engines by programming internal hardware registers (IHR). These IHRs are colocated with the hardware functions they control and are accessed by the PSM via the IHR bus.

The PSM fetches instructions from the microcode memory using an address determined by the program counter, instruction literal, or a program stack. For ALU operations the operands are obtained from shared memory, scratchpad, IHRs, or instruction literals, and the results are written into the shared memory, scratchpad, or IHRs.

Not Recommended for New Designs

There are two basic branch instructions: conditional branches and ALU based branches. To better support the many decision points in the IEEE 802.11 algorithms, branches can depend on either a readily available signals from the hardware modules (branch condition signals are available to the PSM without polling the IHRs), or the results of ALU operations.

WEP

The wired equivalent privacy (WEP) engine encapsulates all the hardware accelerators to perform the encryption and decryption, as well as MIC computation and verification. The accelerators implement the following cipher algorithms: legacy WEP, WPA TKIP, WPA2 AES-CCMP.

The PSM determines, based on the frame type and association information, the appropriate cipher algorithm to be used. It supplies the keys to the hardware engines from an on-chip key table. The WEP interfaces with the TXE to encrypt and compute the MIC on transmit frames, and the RXE to decrypt and verify the MIC on receive frames.

TXE

The transmit engine (TXE) constitutes the transmit data path of the MAC. It coordinates the DMA engines to store the transmit frames in the TXFIFO. It interfaces with WEP module to encrypt frames and transfers the frames across the MAC-PHY interface at the appropriate time determined by the channel access mechanisms.

The data received from the DMA engines are stored in transmit FIFOs. The MAC supports multiple logical queues to support traffic streams that have different QoS priority requirements. The PSM uses the channel access information from the IFS module to schedule a queue from which the next frame is transmitted. Once the frame is scheduled, the TXE hardware transmits the frame based on a precise timing trigger received from the IFS module.

The TXE module also contains the hardware that allows the rapid assembly of MPDUs into an A-MPDU for transmission. The hardware module aggregates the encrypted MPDUs by adding appropriate headers and pad delimiters as needed.

RXE

The receive engine (RXE) constitutes the receive data path of the MAC. It interfaces with the DMA engine to drain the received frames from the RXFIFO. It transfers bytes across the MAC-PHY interface and interfaces with the WEP module to decrypt frames. The decrypted data is stored in the RXFIFO.

The RXE module contains programmable filters that are programmed by the PSM to accept or filter frames based on several criteria such as receiver address, BSSID, and certain frame types.

The RXE module also contains the hardware required to detect A-MPDUs, parse the headers of the containers, and disaggregate them into component MPDUS.

IFS

The IFS module contains the timers required to determine interframe space timing including RIFS timing. It also contains multiple backoff engines required to support prioritized access to the medium as specified by WMM.

The interframe spacing timers are triggered by the cessation of channel activity on the medium, as indicated by the PHY. These timers provide precise timing to the TXE to begin frame transmission. The TXE uses this information to send response frames or perform transmit frame-bursting (RIFS or SIFS separated, as within a TXOP).

The backoff engines (for each access category) monitor channel activity, in each slot duration, to determine whether to continue or pause the backoff counters. When the backoff counters reach 0, the TXE gets notified, so that it may commence frame transmission. In the event of multiple backoff counters decrementing to 0 at the same time, the hardware resolves the conflict based on policies provided by the PSM.

The IFS module also incorporates hardware that allows the MAC to enter a low-power state when operating under the IEEE power save mode. In this mode, the MAC is in a suspended state with its clock turned off. A sleep timer, whose count value is initialized by the PSM, runs on a slow clock and determines the duration over which the MAC remains in this suspended state. Once the timer expires the MAC is restored to its functional state. The PSM updates the TSF timer based on the sleep duration ensuring that the TSF is synchronized to the network.

The IFS module also contains the PTA hardware that assists the PSM in Bluetooth coexistence functions.

TSF

The timing synchronization function (TSF) module maintains the TSF timer of the MAC. It also maintains the target beacon transmission time (TBTT). The TSF timer hardware, under the control of the PSM, is capable of adopting timestamps received from beacon and probe response frames in order to maintain synchronization with the network.

The TSF module also generates trigger signals for events that are specified as offsets from the TSF timer, such as uplink and downlink transmission times used in PSMP.

NAV

The network allocation vector (NAV) timer module is responsible for maintaining the NAV information conveyed through the duration field of MAC frames. This ensures that the MAC complies with the protection mechanisms specified in the standard.

The hardware, under the control of the PSM, maintains the NAV timer and updates the timer appropriately based on received frames. This timing information is provided to the IFS module, which uses it as a virtual carrier-sense indication.

MAC-PHY Interface

The MAC-PHY interface consists of a data path interface to exchange RX/TX data from/to the PHY. In addition, there is a programming interface, which can be controlled either by the host or by the PSM to configure and control the PHY.

WLAN PHY Description

The BCM43241 supports IEEE 802.11a/b/g/n dual-stream to provide maximum data rates up to 300 Mbps.

The PHY has been designed to work with interference, radio nonlinearity, and impairments. It incorporates efficient implementations of the filters, FFT and Viterbi decoder algorithms. Efficient algorithms have been designed to achieve maximum throughput and reliability, including algorithms for carrier sense/rejection, frequency/phase/timing acquisition and tracking, channel estimation and tracking. The PHY receiver also contains a robust IEEE 802.11b demodulator. The PHY carrier sense has been tuned to provide high throughput for IEEE 802.11g/11b hybrid networks with Bluetooth coexistence. It has also been designed for shared single antenna systems between WL and BT to support simultaneous Rx-Rx.

PHY Features

- Supports IEEE 802.11a, 11b, 11g, and 11n dual-stream PHY standards
- IEEE 802.11n dual-stream operation in 20 MHz and 40 MHz channels
- Supports Optional Short GI and Green Field modes in Tx and Rx
- Supports optional space-time block code (STBC) receive of two space-time streams
- Supports IEEE 802.11h/k for worldwide operation
- Advanced algorithms for low power, enhanced sensitivity, range, and reliability
- Supports power saving schemes such as single-core listen (OCL), single-core demodulation of SISO/STBC packets based on RSSI, and dynamic ML turn-off based on RSSI
- Algorithms to improve performance in presence of Bluetooth
- Simultaneous Rx-Rx (WL-BT) architecture
- Automatic gain control scheme for blocking and non blocking application scenario for cellular applications
- Closed-loop transmit power control
- Digital RF chip calibration algorithms to handle CMOS RF chip non-idealities
- On-the-fly channel frequency and transmit power selection
- Supports per packet Rx antenna diversity
- Designed to meet FCC and other worldwide regulatory requirements
- Tx LDPC for improved range and power efficiency
- Hardware support for faster switch times between channels/bands

Not Recommended for New Designs

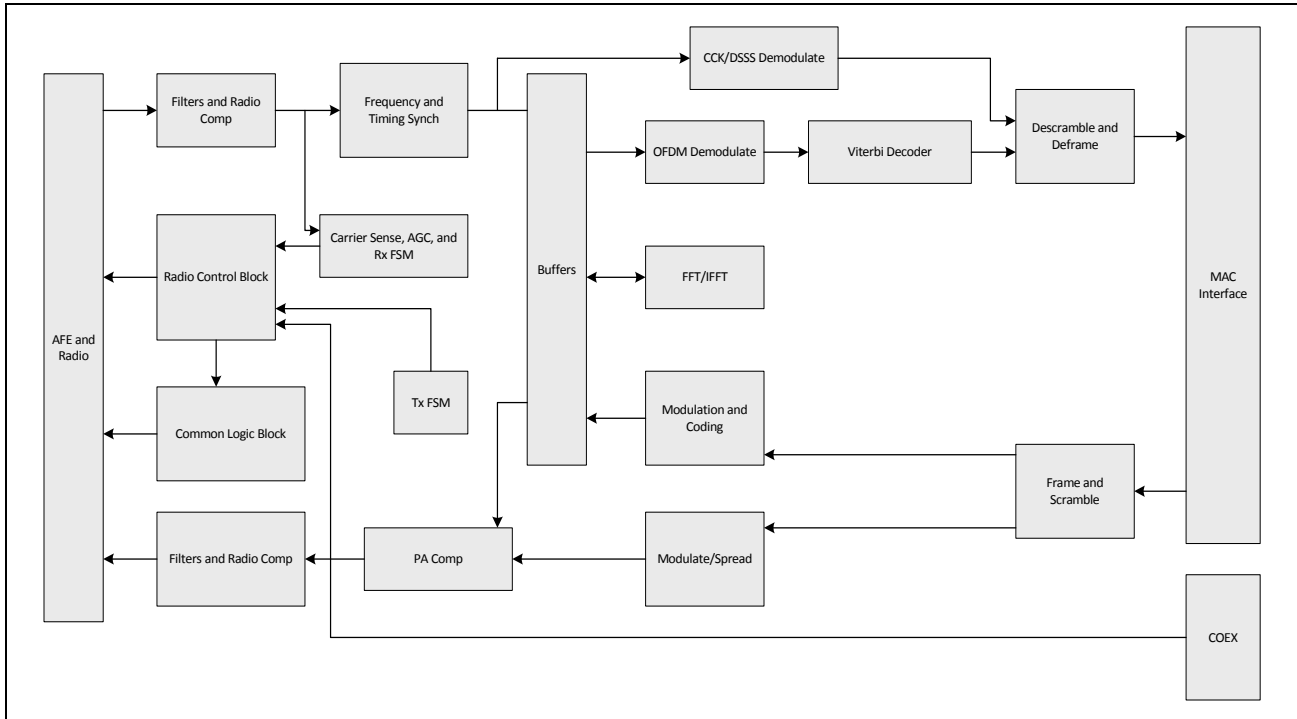

Figure 35: WLAN PHY Block Diagram

The PHY is capable of fully calibrating the RF front end to extract the highest performance. On power-up, the PHY performs a full suite of calibration to correct for IQ mismatch and local oscillator leakage. The PHY also performs periodic calibration to compensate for any temperature related drift thus maintaining high-performance over time. A closed loop transmit control algorithm maintains the output power to required level with capability control Tx power on a per packet basis.

One of the key feature of the PHY is two space-time stream receive capability. The STBC scheme can obtain diversity gains by using multiple transmit antennas in AP (Access Point) in a fading channel environment, without increasing the complexity at the STA. Details of the STBC receive are shown in the block diagram in [Figure 36 on page 85](#).

Not Recommended for New Designs

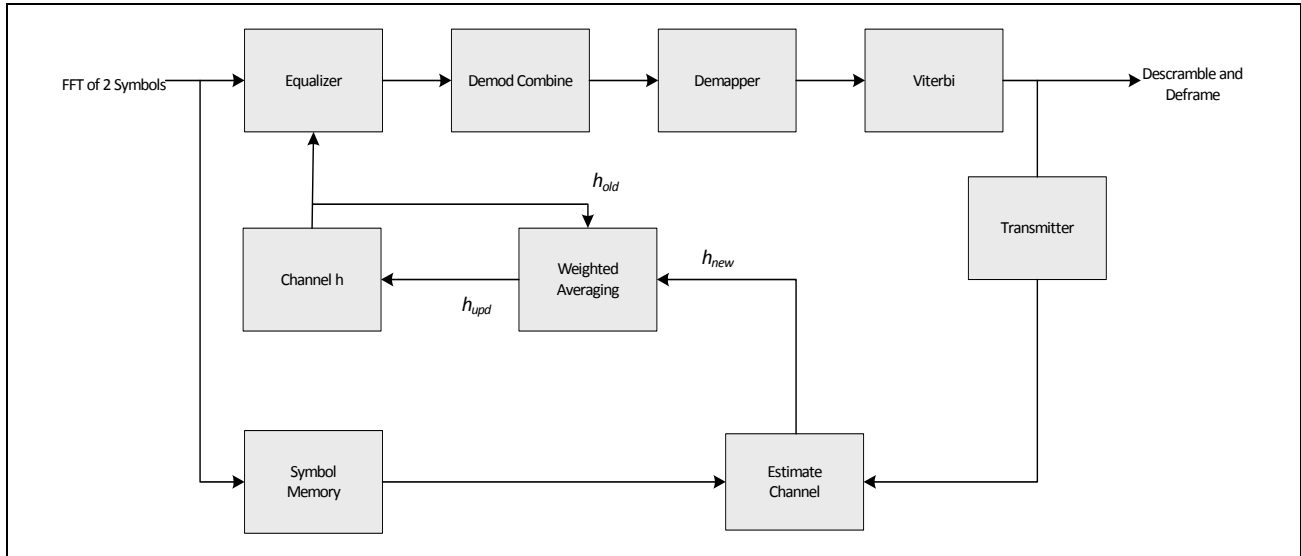

Figure 36: STBC Receive Block Diagram

In STBC mode, symbols are processed in pairs. Equalized output symbols are linearly combined and decoded. Channel estimate is refined on every pair of symbols using the received symbols and reconstructed symbols.

Not Recommended for New Designs

Section 13: WLAN Radio Subsystem

The BCM43241 includes an integrated dual-band WLAN RF transceiver that has been optimized for use in 2.4 GHz and 5 GHz Wireless LAN systems (but not both simultaneously). It has been designed to provide low-power, low-cost, and robust communications for applications operating in the globally available 2.4 GHz unlicensed ISM or 5 GHz U-NII bands. The transmit and receive sections include all on-chip filtering, mixing, and gain control functions.

Up to 11 RF control signals are available to drive the external RF switches and support external power amplifiers and low noise amplifiers for each band. See the reference board schematics for further details.

Receiver Path

The BCM43241 has a wide dynamic range, direct conversion receiver. It employs high order on-chip channel filtering to ensure reliable operation in the noisy 2.4 GHz ISM band or the entire 5 GHz U-NII band. Control signals are available that can support the use of optional external low noise amplifiers (LNA), which can increase the receive sensitivity by several dB.

Transmit Path

Baseband data is modulated and upconverted to the 2.4 GHz ISM or 5 GHz U-NII bands, respectively.

Linear on-chip Power Amplifiers (PA) are included for both 2.4 GHz and 5GHz. Closed loop power control is also provided, as are spare RF control signals that can be used to support external RF switches for either or both bands.

Calibration

The BCM43241 features dynamic and automatic on-chip calibration to continually compensate for temperature and process variation across components. This enables the BCM43241 to be used in high-volume applications, because calibration routines are not required during manufacturing testing. These calibration routines are performed periodically in the course of normal radio operation. Examples of some of the automatic calibration algorithms are baseband filter calibration for optimum transmit and receive performance and LOFT calibration for carrier leakage reduction. In addition, I/Q Calibration, R Calibration, and VCO Calibration are performed on-chip.

Not Recommended for New Designs

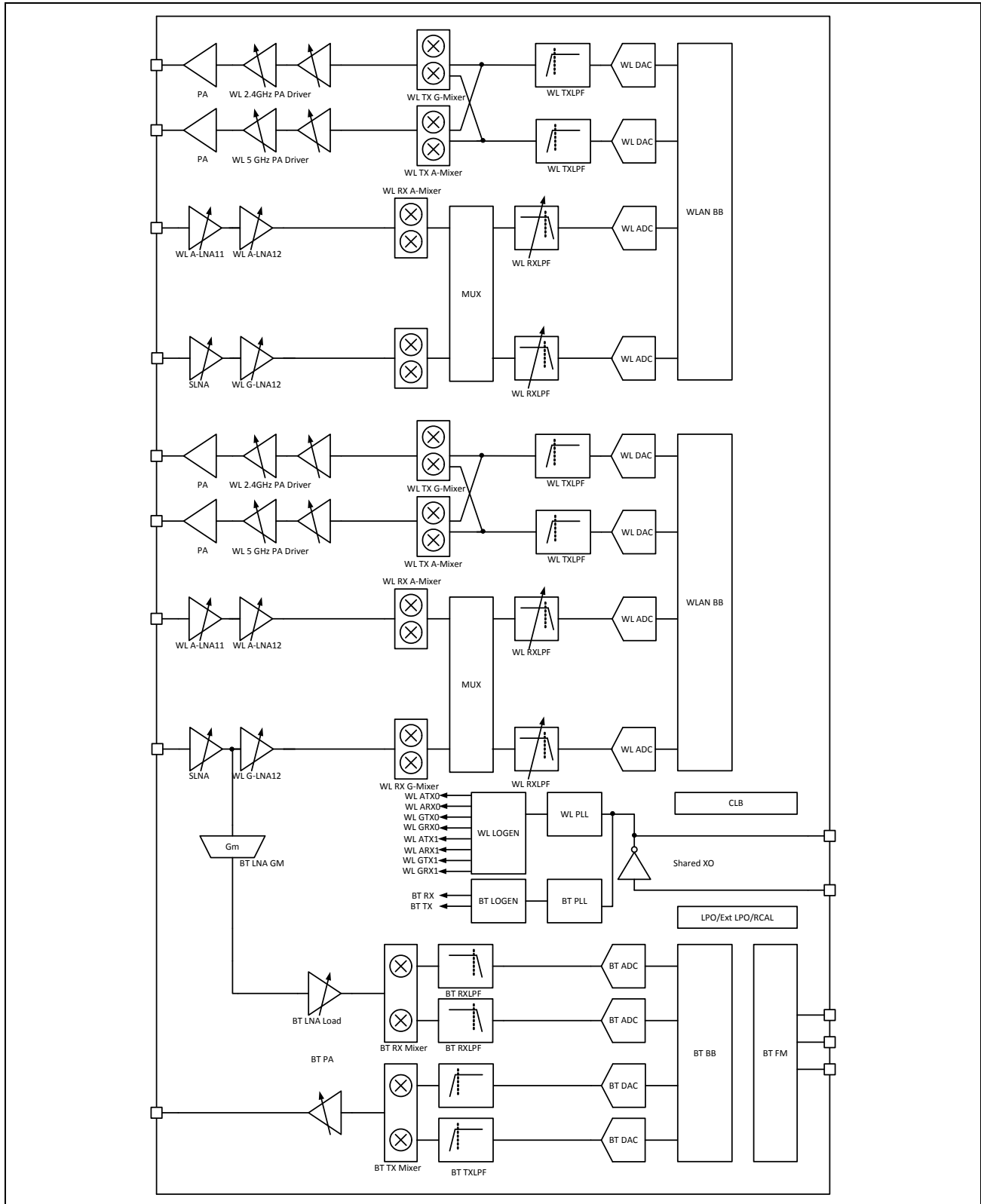

Figure 37: Radio Functional Block Diagram

Not Recommended for New Designs

Section 14: Pinout and Signal Descriptions

Signal Assignments

Figure 38 on page 89 shows the FCFBGA ball map. For pin lists by pin/bump name and number, refer to [Section 26: “Pin List,”](#) on page 167.

Table 17 on page 90 contains the signal description for all packages.

Not Recommended for New Designs

	1	2	3	4	5	6	7	8	9	10	11	12	13	14	15	16	
A	BT_UART_TXD	BT_LPO_IN	BT_PCM_CLK	BT_PCM_OUT	RF_SW_CTRL_7	RF_SW_CTRL_5	RF_SW_CTRL_1	GMODE_EXT_LNA_PU_CORE0	GMODE_PA_EN_CORE0	GPIO_7	GPIO_6	GPIO_3	GPIO_0	GPIO_1	SR_VLX	SR_VLX	A
B	BT_UART_RXD	BT_GPIO_4	BT_I2S_WS	BT_GPIO_3	BT_PCM_IN	RF_SW_CTRL_6	RF_SW_CTRL_3	AMODE_PA_EN_CORE0	GPIO_13	GPIO_8	GPIO_2	JTAG_SEL	EXT_XTAL_PU	SR_PVSS	SR_PVSS	SR_PVSS	B
C	BT_I2S_CLK	BT_UART_RTS_N													SR_VDDBATPSV	SR_VDDBATPSV	C
D	BT_I2S_DO	BT_VDDC_ISO_2		BT_PCM_SYNC	BT_GPIO_2	RF_SW_CTRL_4	RF_SW_CTRL_0	RF_SW_CTRL_2	GPIO_12	AMODE_EXT_LNA_PU_CORE0	GPIO_11	GPIO_5	PMU_AVSS		SR_VDDBATA5V	SR_VDDBATA5V	D
E	BT_CLK_REQ	BT_I2S_DI		BT_VDDC_ISO_1							GPIO_9		VOUT_LDO3P3		VOUT_CLDO	VOUT_CLDO	E
F	BT_HOST_WAKE	BT_UART_CTS_N		BT_VDDO	BT_VDDC	BT_VDDC			GPIO_4						VOUT_LNLD01	VOUT_LNLD01	F
G	BT_TM1	BT_DEV_WAKE													LDO_VDD1P5	LDO_VDD1P5	G
H	FM_VCOVDD	BTFM_RGND		BT_GPIO_5		BT_VDDC	VSS	VDD					VOUT_LNLD02		VOUT_HSICAVDD	HSIC_STROBE	H
J	FM_LNAVDD	BTFM_RGND		FM_PLLVDD		VSS		VDDIO_RF		VSS			WLREG_ON		HSIC_RREFHSIC	HSIC_DATA	J
K	FM_RFIN	FM_RFAUX		BTFM_RGND			VDD	VDD			VDDIO		BTREG_ON		HSIC_DVDD1p2	SDIO_DATA_2	K
L	BT_VCOVDD	BTFM_RGND		BTFM_RGND		VSS	GPIO_10			OTP_VDD33			VSS		SDIO_DATA_1	SDIO_DATA_3	L
M	BT_LNAVDD	BTFM_RGND		BT_PLLVDD		GPIO_15			VSS	VDD	VDDIO_RF	VDDIO_SD	HSIC_AGNDD12PLL		SDIO_DATA_0	SDIO_CLK	M
N	BT_RF	BTFM_RGND		BTFM_RGND		GPIO_14		VDD					RF_SW_CTRL_9		RF_SW_CTRL_11	SDIO_CMD	N
P	BT_PAVDD	BT_VBAT		BT_IFVDD		VSS		VDD	VSS	VDD	RF_SW_CTRL_8	PALDO_PU	GMODE_EXT_LNA_PU_CORE1		AMODE_EXT_LNA_PU_CORE1	RF_SW_CTRL_10	P
R	WRF_RFIN_2G_CORE0	RGND		RGND		VSS					GMODE_PA_EN_CORE1		AMODE_PA_EN_CORE1		VSS	AVDD_BBPLL	R
T	RGND	WRF_RX2G_VDD1P2_CORE0		WRF_PADRV2G_VDD3P3_CORE0		RGND	RGND	RGND	VSS	RGND					WRF_XTAL_CAB_GND1P2	WRF_TCXO_CKIN_ZV	T
U	WRF_PAOUT_2G_CORE0	RGND		RGND						WRF_AFE_VDD1P2_CORE1			WRF_TCXO_VDD1P8		WRF_XTAL_CAB_GND1P2	WRF_XTAL_CAB_XON	U
V	WRF_PA_VDD3P3_CORE0	RGND			WRF_PADRV5G_VDD3P3_CORE0	RGND	WRF_AFE_VDD1P2_CORE0	RGND	RGND	RGND	RGND		WRF_PADRV5G_VDD3P3_CORE1		WRF_XTAL_CAB_VDD1P2	WRF_XTAL_CAB_XOP	V
W	WRF_PAOUT_5G_CORE0	RGND													RGND	RGND	W
Y	RGND		RGND	RGND	RGND	WRF_TX_VDD1P2_CORE0	WRF_GPIO_OUT	WRF_TX_VDD1P2_CORE1	RGND	RGND	WRF_PADRV2G_VDD3P3_CORE1	RGND	RGND	RGND	RGND	WRF_RX5G_VDD1P2_CORE1	Y
AA	WRF_RFIN_5G_CORE0	RGND	WRF_RX5G_VDD1P2_CORE0	RGND	WRF_SYNTH_VDD1P2	RGND	WRF_VCO_VDD1P2	WRF_RX2G_VDD1P2_CORE1	WRF_RFIN_2G_CORE1	RGND	WRF_PAOUT_2G_CORE1	WRF_PA_VDD3P3_CORE1	WRF_PAOUT_5G_CORE1	RGND	WRF_RFIN_5G_CORE1	RGND	AA
	1	2	3	4	5	6	7	8	9	10	11	12	13	14	15	16	

Figure 38: 208-Ball FCBGA Ball Map (Top View)

Not Recommended for New Designs

Signal Descriptions

The signal name, type, and description of each pin in the BCM43241 are listed in [Table 17](#). The symbols shown under Type indicate pin directions (I/O = bidirectional, I = input, O = output) and the internal pull-up/pull-down characteristics (PU = weak internal pull-up resistor and PD = weak internal pull-down resistor), if any. See also [Table 18 on page 98](#) for resistor strapping options.

Table 17: FCFBGA Signal Descriptions

Signal Name	FCFBGA Ball#	Type	Description
WLAN Radio			
AVDD_BBPLL	R16	I	Baseband PLL supply
WRF_XTAL_CAB_XON	U16	O	XTAL output
WRF_XTAL_CAB_XOP	V16	I	XTAL input
WRF_RFIN_2G_CORE1	AA9	I	2.4G RF input core 1
WRF_RFIN_5G_CORE1	AA15	I	5G RF input core 1
WRF_GPIO_OUT	Y7	O	WLAN Radio GPIO
WRF_TCXO_CKIN2V	T16	I	TCXO buffered input. When not using a TCXO this pin should be connected to ground.
WRF_SYNTH_VDD1P2	AA5	I	Clock and miscellaneous supplies
WRF_TCXO_VDD1P8	U13		
WRF_VCO_VDD1P2	AA7		
WRF_XTAL_CAB_VDD1P2	V15		
WRF_XTAL_CAB_GND1P2	T15, U15	I	Clock and miscellaneous grounds
WRF_AFE_VDD1P2_CORE1	U10	I	WLAN core 1 radio supplies
WRF_PADRV2G_VDD3P3_CORE1	Y11		
WRF_PADRV5G_VDD3P3_CORE1	V13		
WRF_TX_VDD1P2_CORE1	Y8		
WRF_RX2G_VDD1P2_CORE1	AA8		
WRF_RX5G_VDD1P2_CORE1	Y16		
WRF_RFIN_2G_CORE0	R1	I	2.4G RF input core 0
WRF_RFIN_5G_CORE0	AA1	I	5G RF input core 0
WRF_PAOUT_2G_CORE0	U1	O	2.4 GHz RF output for Core 0
WRF_PAOUT_2G_CORE1	AA11	O	2.4 GHz RF output for Core 1
WRF_PAOUT_5G_CORE0	W1	O	5 GHz RF output for Core 0
WRF_PAOUT_5G_CORE1	AA13	O	5 GHz RF output for Core 1

Not Recommended for New Designs

Table 17: FCFBGA Signal Descriptions (Cont.)

Signal Name	FCFBGA Ball#	Type	Description
WRF_AFE_VDD1P2_CORE0	V7	I	WLAN core 0 radio supplies
WRF_PADRV2G_VDD3P3_CORE0	T4		
WRF_PADRV5G_VDD3P3_CORE0	V5		
WRF_TX_VDD1P2_CORE0	Y6		
WRF_RX2G_VDD1P2_CORE0	T2		
WRF_RX5G_VDD1P2_CORE0	AA3		
WRF_PA_VDD3P3_CORE1	AA12	I	WLAN PA Supplies (Core 1)
WRF_PA_VDD3P3_CORE0	V1	I	WLAN PA Supplies (Core 0)
WLAN Digital			
HSIC_STROBE	H16	I/O	HSIC strobe
HSIC_DATA	J16	I/O	HSIC data
HSIC_RREFHSIC	J15	I	HSIC reference resistor input. If HSIC is used, connect this pin to ground via a 51-ohm 5% resistor.
HSIC_DVDD1P2	K15	I	HSIC Digital 1.2V supply
SDIO_DATA_3	L16	I/O	SDIO data lines
SDIO_DATA_2	K16		
SDIO_DATA_1	L15		
SDIO_DATA_0	M15		
SDIO_CLK	M16	I	SDIO clock
SDIO_CMD	N16	I	SDIO command
RF_SW_CTRL_0	D7	O	WLAN RF switch control outputs
RF_SW_CTRL_1	A7		
RF_SW_CTRL_2	D8		
RF_SW_CTRL_3	B7		
RF_SW_CTRL_4	D6		
RF_SW_CTRL_5	A6		
RF_SW_CTRL_6	B6		
RF_SW_CTRL_7	A5		
RF_SW_CTRL_8	P11		
RF_SW_CTRL_9	N13		
RF_SW_CTRL_10	P16		
RF_SW_CTRL_11	N15		
GMODE_EXT_LNA_PU_CORE0	A8	O	2.4G external LNA control core 0
AMODE_EXT_LNA_PU_CORE0	D10	O	5G external LNA control core 0
GMODE_PA_EN_CORE0	A9	O	2.4G external PA control core 0

Table 17: FCFBGA Signal Descriptions (Cont.)

Signal Name	FCFBGA Ball#	Type	Description
AMODE_PA_EN_CORE0	B8	O	5G external PA control core 0
GMODE_EXT_LNA_PU_CORE1	P13	O	2.4G external LNA control core 1
AMODE_EXT_LNA_PU_CORE1	P15	O	5G external LNA control core 1
GMODE_PA_EN_CORE1	R11	O	2.4G external PA control core 1
AMODE_PA_EN_CORE1	R13	O	5G external PA control core 1
GPIO_15/UART_TX	M6	I/O	The WLAN GPIO or UART Tx signal
GPIO_14/UART_RX	N6		The WLAN GPIO or UART Rx signal
GPIO_13	B9		WLAN GPIOs
GPIO_11	D11		
GPIO_10	L7		
GPIO_9	E11		
GPIO_8	B10		
GPIO_7	A10		
GPIO_12/ERCX_PRISEL	D9	I/O	
GPIO_6	A11	I/O	GPIO_6/SPI_MODE_SEL (Strap Option)
GPIO_5/TDO/ERCX_TXCONF	D12	I/O	This pin can be programmed to be a GPIO, the JTAG TDO signal, or the external coexistence ERCX_TXCONF signal. The ERCX_TXCONF pin is an output asserted when WLAN is requesting priority. It can be wire-ORed with BT_I2S_DO/ BT_RX_PRIORITY to create the WCN_PRIORITY signal for LTE coexistence.
GPIO_4/TDI/ERCX_RFACTIVE	F10	I/O	This pin can be programmed to be a GPIO, the JTAG TDI signal, or the external coexistence ERCX_RF_ACTIVE signal. The ERCX_RFACTIVE pin is an input that should be asserted by the external coexisting device when it is active. It can be connected with BT_I2S_WS/MWS_RX and then to the LTE modem LTE_PRIORITY signal for LTE coexistence.

Not Recommended for New Designs

Table 17: FCFBGA Signal Descriptions (Cont.)

Signal Name	FCFBGA Ball#	Type	Description
GPIO_3/TMS/ERCX_FREQ	A12	I/O	This pin can be programmed to be a GPIO, the JTAG TMS signal, or the external coexistence ERCX_FREQ signal. The ERCX_FREQ is an input signal that can be connected with BT_I2S_CLK/MWS_TX to create the LTE TX signal for LTE coexistence.
GPIO_2/TCK/ERCX_STATUS	B11	I/O	This pin can be programmed to be a GPIO, the JTAG TCK signal, the external coexistence ERCX_STATUS signal, or an HSIC_READY output to the host, indicating that the device is ready to respond with a CONNECT when it sees IDLE on the HSIC bus. ERCX_STATUS is an input for synchronization with an external coexisting device. It can be connected with BT_I2S_DI/FRAME_SYNC and then to LTE modem LTE_FRAME_SYNC for LTE coexistence.
GPIO_1/WL_DEV_WAKE	A14	I/O	This pin can be programmed to be a GPIO or an AP_READY or HSIC_HOST_READY input from the host indicating that it is awake. This pin is also used as an out-of-band wake-up when the host wants to wake WLAN from the deep sleep mode.
GPIO_0/WL_HOST_WAKE	A13	I/O	This pin can be programmed to be a GPIO or a WLAN_HOST_WAKE output indicating that host wake-up should be performed.
JTAG_SEL	B12	I	JTAG select. The JTAG interface (multiplexed on the GPIO pins) is enabled when this pin is asserted high.
PALDO_PU	P12	O	External PA LDO/Switcher power-up signal
EXT_XTAL_PU	B13	O	External Xtal oscillator power-up signal
VDD	H8, K7, K8, M10, N8, P8, P10	I	Digital always-on core supply

Not Recommended for New Designs

Table 17: FCFBGA Signal Descriptions (Cont.)

Signal Name	FCFBGA Ball#	Type	Description
OTP_VDD33	L10	I	3.3V OTP power supply
VDDIO	K11	I	1.8V to 3.3V IO supply
VDDIO_SD	M12	I	1.8 to 3.3V SDIO IO supply
VDDIO_RF	J8, M11	I	3.3V RF control IO supply
VSS	H7, J6, J10, L6, L13, M9, P6, P9, R6, R15, T9	I	Core ground
HSIC_AGND12PLL	M13	I	Analog ground for HSIC PLL
VOUT_HSICAVDD	H15	O	1.2V output of HSIC LDO, for HSIC PHY analog domain
RGND	R2, R4, T1, T6, T7, T8, T10, U2, U4, V2, V6, V8, V9, V10, V11, W2, W15, W16, Y1, Y3, Y4, Y5, Y9, Y10, Y12, Y13, Y14, Y15, AA2, AA4, AA6, AA10, AA14, AA16	I	WLAN Radio ground
Bluetooth-FM Radio			
BT_IFVDD	P4	I	1.2V Bluetooth IF block power supply
BT_LNAVDD	M1	I	1.2V Bluetooth LNA power supply
BT_PAVDD	P1	I	Bluetooth PA supply
BT_PLLVDD	M4	I	Bluetooth RF PLL power supply
BT_RF	N1	O	Bluetooth transceiver RF antenna port
BT_VBAT	P2	I	VBAT for Bluetooth
BT_VCOVDD	L1	I	Bluetooth VCO Supply
FM_LNAVDD	J1	I	FM receiver power supply
FM_PLLVDD	J4	I	FM PLL power supply

Not Recommended for New Designs

Table 17: FCFBGA Signal Descriptions (Cont.)

Signal Name	FCFBGA Ball#	Type	Description
FM_RFAUX	K2	I	FM radio auxiliary antenna port
FM_RFIN	K1	I	FM radio antenna port
FM_VCOVDD	H1	I	FM VCO supply
BTFM_RGND	H2, J2, K4, L2, L4, M2, N2, N4	I	BT/FM Radio ground
Bluetooth-FM Digital			
BT_TM1	G1	I/O	BT test mode pin
BT_DEV_WAKE	G2	I/O	BT device wake
BT_HOST_WAKE	F1	I/O	BT host wake
BT_GPIO_2	D5	I/O	BT GPIO
BT_GPIO_3	B4	I/O	BT GPIO
BT_GPIO_4	B2	I/O	BT GPIO
BT_GPIO_5	H4	I/O	BT GPIO
BT_UART_CTS_N	F2	I/O	UART clear-to-send. Active-low clear-to-send signal for the HCI UART interface
BT_UART_RTS_N	C2	I/O	UART request-to-send. Active-low request-to-send signal for the HCI UART interface
BT_UART_TXD	A1	I/O	UART serial output. Serial data output for the HCI UART interface
BT_UART_RXD	B1	I/O	UART serial input. Serial data input for the HCI UART interface
BT_I2S_CLK	C1	I/O	I2S clock; can be master (output) or slave (input)
BT_I2S_DO	D1	I/O	I2S data output
BT_I2S_DI	E2	I/O	I2S data input
BT_I2S_WS	B3	I/O	I2S WS: can be master (output) or slave (input)
BT_PCM_IN	B5	I/O	PCM data input or SLIMbus transport sensing
BT_PCM_CLK	A3	I/O	PCM or SLIMbus clock; can be master (output) or slave (input)
BT_PCM_SYNC	D4	I/O	PCM sync; can be master (output) or slave (input); or SLIMbus data
BT_PCM_OUT	A4	I/O	PCM data output
BT_CLK_REQ	E1	I/O	BT clock request

Table 17: FCFBGA Signal Descriptions (Cont.)

Signal Name	FCFBGA Ball#	Type	Description
BT_LPO_IN	A2	I	External sleep clock input (32.758 kHz)
BT_VDDC	F5, F6, H6	I	BT digital core 1.2V supply
BT_VDDC_ISO_1	E4	I	Core supply for power-on/off island VDDC_G
BT_VDDC_ISO_2	D2	I	Core supply for power-on/off island VDDB
BT_VDDO	F4	I	I/O supply for Bluetooth
PMU			
SR_PVSS	B14, B15, B16	I	Switcher ground
SR_VDDBATA5V	D15, D16	I	Battery voltage input for band-gap and LDO3P3
SR_VDDBATP5V	C15, C16	I	Battery voltage input for the CBUCK switcher
SR_VLX	A15, A16	O	Switcher output (1.35V default)
LDO_VDD1P5	G15, G16	I	LDO input for CLDO, HSICLDO, LNLDO1, and LNLDO2. Also voltage feedback input for CBUCK. (1.35V default)
BTREG_ON	K13	I	Used by PMU to power up or power down the internal BCM43241 regulators used by the Bluetooth/FM section. Also, when deasserted, this pin holds the Bluetooth/FM section in reset. This pin has an internal 200 kΩ pull-down resistor that is enabled by default. It can be disabled through programming.
WLREG_ON	J13	I	Used by PMU to power up or power down the internal BCM43241 regulators used by the WLAN section. Also, when deasserted, this pin holds the WLAN section in reset. This pin has an internal 200 kΩ pull-down resistor that is enabled by default. It can be disabled through programming.
PMU_AVSS	D13	I	PMU ground
VOUT_LDO3P3	E13	O	3.3V LDO output
VOUT_LNLDO1	F15, F16	O	1.2V LNLDO1 output
VOUT_LNLDO2	H13	O	1.2V LNLDO2 output

Not Recommended for New Designs

Table 17: FCFBGA Signal Descriptions (Cont.)

Signal Name	FCFBGA Ball#	Type	Description
VOUT_CLDO	E15, E16	O	1.2V Digital core LDO output

Not Recommended for New Designs

WLAN GPIO Signals and Strapping Options

The pins listed in [Table 18](#) are sampled at power-on reset (POR) to determine the various operating modes. Sampling occurs a few milliseconds after an internal POR or deassertion of the external POR. After the POR, each pin assumes the GPIO or alternative function specified in the signal descriptions table. Each strapping option pin has an internal pull-up (PU) or pull-down (PD) resistor that determines the default mode. To change the mode, connect an external PU resistor to VDDIO or a PD resistor to GND, using a 10 kΩ resistor or less.



Note: Refer to the reference board schematics for more information.

Table 18: WLAN GPIO Functions and Strapping Options (Advance Information)

Pin Name	FCFBGA Pin	Default	Function	Description
SDIO_DATA_1	L15	0	strap_host_ifc_1	The three strap pins strap_host_ifc_[3:1] together select the host interface to enable: 0XX: SDIO 10X: gSPI 110: normal HSIC 111: bootloader-less HSIC
SDIO_DATA_2	K16	0	strap_host_ifc_2	–
GPIO_6	A11	0	strap_host_ifc_3	–
GPIO_7	A10	1	OTPEnabled	When this bit is 0, OTP is not powered up by default, but SW can enable it by altering MInRsrcMask. This pin also selects the use of OTP or the default CIS in the SDIO core, as described in the OTP select table (see Table 19).
GPIO_8	B10	0	strap_sflashPresent_sdioPadVddio	In SDIO mode, this pin acts as sdio_padVddio strap. In USB mode, this pin acts as sflashPresent strap.
GPIO_9	E11	1	ARM Remap[0]	0: Boot from SRAM, ARM held in reset. 1: Boot from ROM by remapping the ARM core exception vectors there, ARM running out of reset.
GPIO_10	L7	0	spromPresent/flashType	When this bit is set to 1, this pin selects the use of an external SPROM multiplexed onto the GPIO lines. GPIO8 = CLK, GPIO9 = CS, GPIO10 = input data from SPROM, GPIO11 = data output to SPROM If sflashPresent = 1, then this strapping option decides the type of sflash used.

Table 18: WLAN GPIO Functions and Strapping Options (Advance Information) (Cont.)

Pin Name	FCFBGA Pin	Default	Function	Description
GPIO_11	D11	0	IlpDivEn	0: Select external sleep clock or LPO clock (based on the value on LPOSelect strap) as ILP clock. 1: Select the clock derived by dividing the ALP clock by IlpDiv. If this field is set to 1, the ResourceInitMode option must be set to 10 for ALP clock available.
GPIO_13	B9	0	LPOSelect	0: Select external sleep clock as ILP clock. 1: Select internal LPO clock. This value is ignored if the LPOAutoDetEn option is set to 1.
GPIO_15, GPIO_14	M6 N6	10	ResourceInitMode [1:0]	00: For PMU to power up to ILP clock available (no backplane clock), 01: Power up to ILP clock request. 10: ALP clock available. 11: HT clock available. This field must be set to 10 for the ALP clock available if IlpDivEn strap is set to 1. This field may not be set to 11 for implementations using an oscillator running at other than 30 MHz because the PLL must be reprogrammed before it is enabled.

Table 19: OTP Select

UseSprom	OTPEnabled	OTP State	CIS Source	ChipID Source
0	0	OFF	Default	Default
0	1	ON	OTP if programmed, else default.	OTP if programmed, else default.
1	0	OFF	SPROM	Default
1	1	ON	SPROM	OTP if programmed, else default.

Not Recommended for New Designs

Table 20: WLAN GPIO Functions and Strapping Options (Advance Information)

Pin Name	FCFBGA Pin	Default	Function	Description
SDIO_DATA_1	L15	0	strap_host_ifc_1	The three pins strap_host_ifc_[3:1] together select the host interface mode: <ul style="list-style-type: none"> • 0XX: SDIO • 10X: gSPI • 110: normal HSIC • 111: bootloader-less HSIC
SDIO_DATA_2	K16	0	strap_host_ifc_2	
GPIO_6	A11	0	strap_host_ifc_3	

Not Recommended for New Designs

Multiplexed Bluetooth GPIO Signals

The Bluetooth GPIO pins (BT_GPIO_0 to BT_GPIO_7) are multiplexed pins and can be programmed to be used as GPIOs or for other Bluetooth interface signals such as I²S. The specific function for a given BT_GPIO_X pin is chosen by programming the Pad Function Control Register for that specific pin. Table 21 shows the possible options for each BT_GPIO_X pin. Note that each BT_GPIO_X pin's Pad Function Control Register Setting is independent (BT_GPIO_1 can be set to Pad Function 7 at the same time that BT_GPIO_3 is set to PAD Function 0). When the Pad Function Control Register is set to 0 the BT_GPIOs do not have specific functions assigned to them and behave as generic GPIOs. The A_GPIO_X pins described below are multiplexed behind the BCM43241 PCM and I²S interface pins.

Table 21: GPIO Multiplexing Matrix

Pin Name	Pad Function Control Register Setting							
	0	1	2	3	4	5	6	7
BT_UART_CTS_N	UART_CTS_N	–	–	–	–	–	–	A_GPIO[1]
BT_UART_RTS_N	UART_RTS_N	–	–	–	–	–	–	A_GPIO[0]
BT_UART_RXD	UART_RXD	–	–	–	–	–	–	GPIO[5]
BT_UART_TXD	UART_TXD	–	–	–	–	–	–	GPIO[4]
BT_PCM_IN	A_GPIO[3]	PCM_IN	PCM_IN	HCLK	–	–	–	I2S_SSDI/MSDI
BT_PCM_OUT	A_GPIO[2]	PCM_OUT	PCM_OUT	LINK_IND	–	I2S_MSDO	–	I2S_SSDO
BT_PCM_SYNC	A_GPIO[1]	PCM_SYNC	PCM_SYNC	HCLK	INT_LPO	I2S_MWS	–	I2S_SWS
BT_PCM_CLK	A_GPIO[0]	PCM_CLK	PCM_CLK	–	–	I2S_MSCK	–	I2S_SSCK
BT_I2S_DO	A_GPIO[5]	PCM_OUT	–	–	I2S_SSDO	I2S_MSDO	–	STATUS
BT_I2S_DI	A_GPIO[6]	PCM_IN	–	HCLK	I2S_SSDI/ MSDI	–	–	TX_CON_FX
BT_I2S_WS	GPIO[7]	PCM_SYNC	–	LINK_IND	–	I2S_MWS	–	I2S_SWS
BT_I2S_CLK	GPIO[6]	PCM_CLK	–	–	INT_LPO	I2S_MSCK	–	I2S_SSCK
BT_GPIO_1	GPIO[1]	–	–	–	–	–	–	CLASS1[2]
BT_GPIO_0	GPIO[0]	–	–	–	clk_12p288	–	–	–
CLK_REQ	WL/BT_CLK_REQ	–	–	–	–	–	–	A_GPIO[7]

The multiplexed GPIO signals are described in [Table 22](#).

Table 22: Multiplexed GPIO Signals

Pin Name	Type	Description
UART_CTS_N	I	Host UART clear to send
UART_RTS_N	O	Device UART request to send
UART_RXD	I	Device UART receive data
UART_TXD	O	Host UART transmit data
PCM_IN	I	PCM data input
PCM_OUT	O	PCM data output
PCM_SYNC	I/O	PCM sync signal, can be master (output) or slave (input)
PCM_CLK	I/O	PCM clock, can be master (output) or slave (input)
GPIO[7:0]	I/O	General-purpose I/O
A_GPIO[7:0]	I/O	A group general-purpose I/O
I2S_MSDO	O	I ² S master data output
I2S_MWS	O	I ² S master word select
I2S_MSCK	O	I ² S master clock
I2S_SSCK	I	I ² S slave clock
I2S_SSDO	O	I ² S slave data output
I2S_SWS	I	I ² S slave word select
I2S_SSDI/MSDI	I	I ² S slave/master data input
STATUS	O	Signals Bluetooth priority status
TX_CON_FX	I	WLAN-BT coexist. Transmission confirmation; permission for BT to transmit
RF_ACTIVE	O	WLAN-BT coexist. Asserted (logic high) during local BT RX and TX slots
LINK_IND	O	BT receiver/transmitter link indicator
CLK_REQ	O	WLAN/BT clock request output

I/O States

The following notations are used in [Table 23](#):

- I: Input signal
- O: Output signal
- I/O: Input/Output signal
- PU = Pulled up
- PD = Pulled down
- NoPull = Neither pulled up nor pulled down

Table 23: I/O States

Name	I/O	Keeper	Active Mode	Low Power State/ Sleep (All Power Present)	Power-Down (BT_REG_ON and WL_REG_ON Held Low)	Out-of-Reset; Before SW Download (BT_REG_ON=1; WL_REG_ON=1)	(WL_REG_ON=1 and BT_REG_ON=0) and VDDIOs Are Present	(WL_REG_ON=0 and BT_REG_ON=1) and VDDIOs Are Present	Power Rail
WL_REG_ON	I	N	Input; PD (pull-down can be disabled)	Input; PD (pull-down can be disabled)	Input; PD (of 200K)	Input; PD (of 200K)	Input; PD (of 200K)		–
BT_REG_ON	I	N	Input; PD (pull down can be disabled)	Input; PD (pull down can be disabled)	Input; PD (of 200K)	Input; PD (of 200K)	Input; PD (of 200K)		–
CLK_REQ	I/O	Y	Open drain or push- pull (programmable). Active high.	Open drain or push- pull (programmable). Active-high	High-Z, NoPull	Open drain. Active- high	Open drain. Active- high.		BT_VDDO
BT_HOST_WAKE	I/O	Y	Input/Output; PU, PD, NoPull (programmable)	Input/Output; PU, PD, NoPull (programmable)	High-Z, NoPull	Input, PD	Input, PD		BT_VDDO
BT_DEV_WAKE	I/O	Y	Input/Output; PU, PD, NoPull (programmable)	Input; PU, PD, NoPull (programmable)	High-Z, NoPull	Input, PD	Input, PD		BT_VDDO
BT_GPIO 2,3,4,5	I/O	Y	Input/Output; PU, PD, NoPull (programmable)	Input/Output; PU, PD, NoPull (programmable)	High-Z, NoPull	Input, PD	Input, PD		BT_VDDO
BT_UART_CTS	I	Y	Input; NoPull	Input; NoPull	High-Z, NoPull	Input; PU	Input; PU		BT_VDDO
BT_UART_RTS	O	Y	Output; NoPull	Output; NoPull	High-Z, NoPull	Input; PU	Input; PU		BT_VDDO

Table 23: I/O States (Cont.)

Name	I/O	Keeper	Active Mode	Low Power State/ Sleep (All Power Present)	Power-Down (BT_REG_ON and WL_REG_ON Held Low)	Out-of-Reset; Before SW Download (BT_REG_ON=1; WL_REG_ON=1)	(WL_REG_ON=1 and BT_REG_ON=0) and VDDIOs Are Present	(WL_REG_ON=0 and BT_REG_ON=1) and VDDIOs Are Present	Power Rail
BT_UART_RXD	I	Y	Input; PU	Input; NoPull	High-Z, NoPull	Input; PU	Input; PU		BT_VDDO
BT_UART_TXD	O	Y	Output; NoPull	Output; NoPull	High-Z, NoPull	Input; PU	Input; PU		BT_VDDO
SDIO Data	I/O	N	Input/Output; PU	Input; PU	High-Z, NoPull	Input; PU	Input; PU		WL_VDDIO
SDIO CMD	I/O	N	Input/Output; PU	Input; PU	High-Z, NoPull	Input; PU	Input; PU		WL_VDDIO
SDIO_CLK	I	N	Input; NoPull	Input; NoPull	High-Z, NoPull	Input; NoPull	Input; NoPull		WL_VDDIO
BT_PCM_CLK	I/O	Y	Input; NoPull (Note 4)	Input; NoPull (Note 4)	High-Z, NoPull	Input, PD	Input, PD		BT_VDDO
BT_PCM_IN	I/O	Y	Input; NoPull (Note 4)	Input; NoPull (Note 4)	High-Z, NoPull	Input, PD	Input, PD		BT_VDDO
BT_PCM_OUT	I/O	Y	Input; NoPull (Note 4)	Input; NoPull (Note 4)	High-Z, NoPull	Input, PD	Input, PD		BT_VDDO
BT_PCM_SYNC	I/O	Y	Input; NoPull (Note 4)	Input; NoPull (Note 4)	High-Z, NoPull	Input, PD	Input, PD		BT_VDDO
BT_I2S_WS	I/O	Y	Input; NoPull (Note 5)	Input; NoPull (Note 5)	High-Z, NoPull	Input, PD	Input, PD		BT_VDDO
BT_I2S_CLK	I/O	Y	Input; NoPull (Note 5)	Input; NoPull (Note 5)	High-Z, NoPull	Input, PD	Input, PD		BT_VDDO
BT_I2S_DI	I/O	Y	Input; NoPull (Note 5)	Input; NoPull (Note 5)	High-Z, NoPull	Input, PD	Input, PD		BT_VDDO
BT_I2S_DO	I/O	Y	Input; NoPull (Note 5)	Input; NoPull (Note 5)	High-Z, NoPull	Input, PD	Input, PD		BT_VDDO
WL GPIO_0	I/O	Y	Input/Output; PU, PD, NoPull (programmable [Default: PD])	Input/Output; PU, PD, NoPull (programmable [Default: PD])	High-Z, NoPull	Input; PD	Input; PD		WL_VDDIO
WL GPIO_1	I/O	Y	Input/Output; PU, PD, NoPull (programmable [Default: PU])	Input/Output; PU, PD, NoPull (programmable [Default: PU])	High-Z, NoPull	Input; PU	Input; PU		WL_VDDIO
WL GPIO_2	I/O	Y	Input/Output; PU, PD, NoPull (programmable [Default: PU])	Input/Output; PU, PD, NoPull (programmable [Default: PU])	High-Z, NoPull	Input; PU	Input; PU		WL_VDDIO
WL GPIO_3	I/O	Y	Input/Output; PU, PD, NoPull (programmable [Default: PU])	Input/Output; PU, PD, NoPull (programmable [Default: PU])	High-Z, NoPull	Input; PU	Input; PU		WL_VDDIO

Table 23: I/O States (Cont.)

Name	I/O	Keeper	Active Mode	Low Power State/ Sleep (All Power Present)	Power-Down (BT_REG_ON and WL_REG_ON Held Low)	Out-of-Reset; Before SW Download (WL_REG_ON=1; BT_REG_ON=1; WL_REG_ON=1)	(WL_REG_ON=1 and BT_REG_ON=0) and VDDIOs Are Present	(WL_REG_ON=0 and BT_REG_ON=1) and VDDIOs Are Present	Power Rail
WL GPIO_4	I/O	Y	Input/Output; PU, PD, NoPull (programmable [Default: noPull])	Input/Output; PU, PD, NoPull (programmable [Default: noPull])	High-Z, NoPull	Input; NoPull	Input; NoPull		WL_VDDIO
WL GPIO_5	I/O	Y	Input/Output; PU, PD, NoPull (programmable [Default: PU])	Input/Output; PU, PD, NoPull (programmable [Default: PU])	High-Z, NoPull	Input; PU	Input; PU		WL_VDDIO
WL GPIO_6	I/O	Y	Input/Output; PU, PD, NoPull (programmable [Default: PD])	Input/Output; PU, PD, NoPull (programmable [Default: PD])	High-Z, NoPull	Input; PD	Input; PD		WL_VDDIO

Note:

1. Keeper column: N=pad has no keeper. Y=pad has a keeper. Keeper is always active except in Power-down state.
2. If there is no keeper, and it is an input and there is Nopull, then the pad should be driven to prevent leakage due to floating pad (SDIO_CLK, for example).
3. In the Power-down state (xx_REG_ON=0): High-Z; NoPull => the pad is disabled because power is not supplied.
4. Depending on whether the PCM interface is enabled and the configuration of PCM is in master or slave mode, it can be either output or input.
5. Depending on whether the I²S interface is enabled and the configuration of I²S is in master or slave mode, it can be either output or input.

Section 15: DC Characteristics



Note: Values in this data sheet are design goals and are subject to change based on the results of device characterization.

Absolute Maximum Ratings



Caution! The absolute maximum ratings in [Table 24](#) indicate levels where permanent damage to the device can occur, even if these limits are exceeded for only a brief duration. Functional operation is not guaranteed under these conditions. Operation at absolute maximum conditions for extended periods can adversely affect long-term reliability of the device.

Table 24: Absolute Maximum Ratings

Rating	Symbol	Value	Unit
DC supply for VBAT	VBAT	-0.5 to +5.5	V
DC supply voltage for I/O	VDDIO	-0.5 to 3.8	V
DC supply voltage for RF	VDDRF	-0.5 to 1.32	V
DC supply voltage for core	VDDC	-0.5 to 1.32	V
DC supply voltage for RF I/Os and PA supply	VDDIO_RF	-0.5 to 3.8	V
DC input supply voltage for CLDO and LNLDO1	–	-0.5 to 2.1	V
WRF_TCXO_VDD	–	-0.5 to 1.98	V
Maximum undershoot voltage for I/O	V _{undershoot}	-0.5	V
Maximum Junction Temperature	T _j	125	°C

Not Recommended for New Designs

Environmental Ratings

The environmental ratings are shown in [Table 25](#).

Table 25: Environmental Ratings

Characteristic	Value	Units	Conditions/Comments
Ambient Temperature (T_A)	-30 to +85	°C	Functional operation ^a
Storage Temperature	-40 to +125	°C	–
Relative Humidity	Less than 60	%	Storage
	Less than 85	%	Operation

- a. Functionality is guaranteed but specifications require derating at extreme temperatures; see the specification tables for details.

Electrostatic Discharge Specifications

Extreme caution must be exercised to prevent electrostatic discharge (ESD) damage. Proper use of wrist and heel grounding straps to discharge static electricity is required when handling these devices. Always store unused material in its antistatic packaging.

Table 26: ESD Specifications

Pin Type	Symbol	Condition	ESD Rating	Unit
ESD, Handling Reference: NQY00083, Section 3.4, Group D9, Table B	ESD_HAND_HBM	Human body model contact discharge per JEDEC EID/JESD22-A114	TBD	V
Machine Model (MM)	ESD_HAND_MM	Machine model contact	TBD	V
CDM	ESD_HAND_CDM	Charged device model contact discharge per JEDEC EIA/JESD22-C101	TBD	V

Not Recommended for New Designs

Recommended Operating Conditions and DC Characteristics



Caution! Functional operation is not guaranteed outside of the limits shown in [Table 27](#) and operation outside these limits for extended periods can adversely affect long-term reliability of the device.

Table 27: Recommended Operating Conditions and DC Characteristics

Parameter	Symbol	Value			Unit
		Minimum	Typical	Maximum	
DC supply voltage for VBAT	VBAT	2.3 ^a	–	4.8 ^b	V
DC supply voltage for core	VDD	1.14	1.2	1.26	V
DC supply voltage for RF blocks in chip	VDDRF	1.14	1.2	1.26	V
DC supply voltage for TCXO input buffer	WRF_TCXO_VDD	1.62	1.8	1.98	V
SDIO Interface I/O Pins					
For VDDIO_SD = 1.8V:					
Input high voltage	VIH	1.27	–	–	V
Input low voltage	VIL	–	–	0.58	V
Output high voltage @ 2 mA	VOH	1.40	–	–	V
Output low voltage @ 2 mA	VOL	–	–	0.45	V
For VDDIO_SD = 3.3V:					
Input high voltage	VIH	0.625 × VDDIO	–	–	V
Input low voltage	VIL	–	–	0.25 × VDDIO	V
Output high voltage @ 2 mA	VOH	0.75 × VDDIO	–	–	V
Output low voltage @ 2 mA	VOL	–	–	0.125 × VDDIO	V
Other Digital I/O Pins					
For VDDIO = 1.8V:					
Input high voltage	VIH	0.65 × VDDIO	–	–	V
Input low voltage	VIL	–	–	0.35 × VDDIO	V
Output high voltage @ 2 mA	VOH	VDDIO – 0.45	–	–	V
Output low voltage @ 2 mA	VOL	–	–	0.45	V
For VDDIO = 3.3V:					

Not Recommended for New Designs

Table 27: Recommended Operating Conditions and DC Characteristics (Cont.)

Parameter	Symbol	Value			Unit
		Minimum	Typical	Maximum	
Input high voltage	V _{IH}	2.00	–	–	V
Input low voltage	V _{IL}	–	–	0.80	V
Output high voltage @ 2 mA	V _{OH}	V _{DDIO} – 0.4	–	–	V
Output Low Voltage @ 2 mA	V _{OL}	–	–	0.40	V
RF Switch Control Output Pins					
For V _{DDIO_RF} = 3.3V:					
Output High Voltage @ 2 mA	V _{OH}	V _{DDIO} – 0.4	–	–	V
Output Low Voltage @ 2 mA	V _{OL}	–	–	0.40	V
Input capacitance	C _{IN}	–	–	5	pF

- The BCM43241 is functional across this range of voltages. Optimal RF performance specified in the data sheet, however, is guaranteed only for 3.0V < V_{BAT} < 4.8V.
- The maximum continuous supply voltage is 4.8V. Brief spikes above 4.8V can be tolerated. Specifically, voltages as high as 5.5V for up to 10 seconds cumulative duration over the lifetime of the device are allowed. Voltages as high as 5.0V for up to 250 seconds cumulative duration over the lifetime of the device are allowed.

Section 16: Bluetooth RF Specifications



Note: Values in this data sheet are design goals and are subject to change based on the results of device characterization.

Unless otherwise stated, limit values apply for the conditions specified in [Table 25: “Environmental Ratings,” on page 107](#) and [Table 27: “Recommended Operating Conditions and DC Characteristics,” on page 108](#). Typical values apply for the following conditions:

- VBAT = 3.6V
- Ambient temperature +25°C

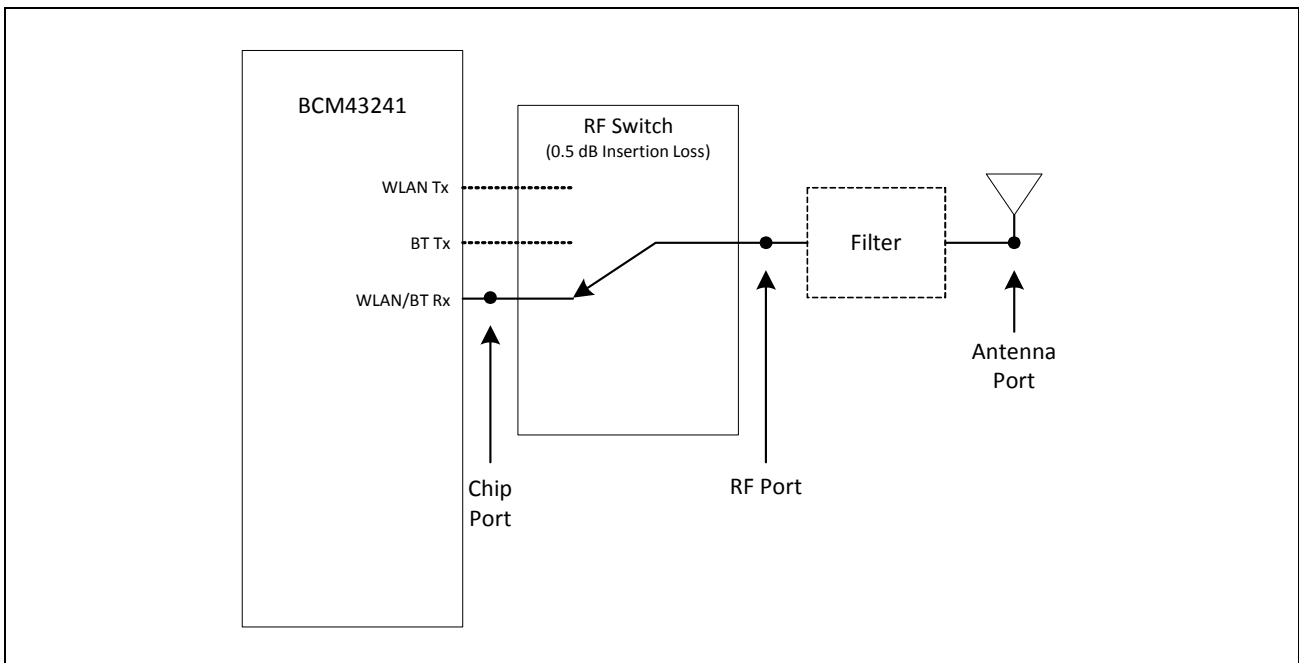

Figure 39: RF Port Location for Bluetooth Testing



Note: All Bluetooth specifications are measured at the Chip port unless otherwise specified.

Not Recommended for New Designs

Table 28: Bluetooth Receiver RF Specifications

Parameter	Conditions	Minimum	Typical	Maximum	Unit
Note: The specifications in this table are measured at the Chip port output unless otherwise specified.					
General					
Frequency range	–	2402	–	2480	MHz
RX sensitivity	GFSK, 0.1% BER, 1 Mbps	–	–93.5	–	dBm
	$\pi/4$ -DQPSK, 0.01% BER, 2 Mbps	–	–95.5	–	dBm
	8-DPSK, 0.01% BER, 3 Mbps	–	–89.5	–	dBm
Input IP3	–	–16	–	–	dBm
Maximum input at antenna	–	–	–	–20	dBm
Interference Performance^a					
C/I co-channel	GFSK, 0.1% BER	–	8.5	–	dB
C/I 1-MHz adjacent channel	GFSK, 0.1% BER	–	–5	–	dB
C/I 2-MHz adjacent channel	GFSK, 0.1% BER	–	–35	–	dB
C/I \geq 3-MHz adjacent channel	GFSK, 0.1% BER	–	–49	–	dB
C/I image channel	GFSK, 0.1% BER	–	–31	–	dB
C/I 1-MHz adjacent to image channel	GFSK, 0.1% BER	–	–42	–	dB
C/I co-channel	$\pi/4$ -DQPSK, 0.1% BER	–	10	–	dB
C/I 1-MHz adjacent channel	$\pi/4$ -DQPSK, 0.1% BER	–	–10	–	dB
C/I 2-MHz adjacent channel	$\pi/4$ -DQPSK, 0.1% BER	–	–35	–	dB
C/I \geq 3-MHz adjacent channel	8-DPSK, 0.1% BER	–	–50	–	dB
C/I image channel	$\pi/4$ -DQPSK, 0.1% BER	–	–28	–	dB
C/I 1-MHz adjacent to image channel	$\pi/4$ -DQPSK, 0.1% BER	–	–45	–	dB
C/I co-channel	8-DPSK, 0.1% BER	–	17	–	dB
C/I 1 MHz adjacent channel	8-DPSK, 0.1% BER	–	–4	–	dB
C/I 2 MHz adjacent channel	8-DPSK, 0.1% BER	–	–33	–	dB
C/I \geq 3-MHz adjacent channel	8-DPSK, 0.1% BER	–	–47	–	dB
C/I Image channel	8-DPSK, 0.1% BER	–	–21	–	dB
C/I 1-MHz adjacent to image channel	8-DPSK, 0.1% BER	–	–39	–	dB

Not Recommended for New Designs

Table 28: Bluetooth Receiver RF Specifications (Cont.)

<i>Parameter</i>	<i>Conditions</i>	<i>Minimum</i>	<i>Typical</i>	<i>Maximum</i>	<i>Unit</i>
Out-of-Band Blocking Performance (CW)					
30–2000 MHz	0.1% BER	–	–10.0	–	dBm
2000–2399 MHz	0.1% BER	–	–27	–	dBm
2498–3000 MHz	0.1% BER	–	–27	–	dBm
3000 MHz–12.75 GHz	0.1% BER	–	–10.0	–	dBm
Out-of-Band Blocking Performance, Modulated Interferer					
GFSK (1 Mbps)^b					
698–716 MHz	WCDMA	–	–8.5	–	dBm
776–794 MHz	WCDMA	–	–8.5	–	dBm
824–849 MHz	GSM850	–	–10.9	–	dBm
824–849 MHz	WCDMA	–	–10.5	–	dBm
880–915 MHz	E-GSM	–	–11.3	–	dBm
880–915 MHz	WCDMA	–	–10.9	–	dBm
1710–1785 MHz	GSM1800	–	–17.3	–	dBm
1710–1785 MHz	WCDMA	–	–16.4	–	dBm
1850–1910 MHz	GSM1900	–	–18.5	–	dBm
1850–1910 MHz	WCDMA	–	–17.8	–	dBm
1880–1920 MHz	TD-SCDMA	–	–18.8	–	dBm
1920–1980 MHz	WCDMA	–	–18.1	–	dBm
2010–2025 MHz	TD-SCDMA	–	–19.3	–	dBm
2500–2570 MHz	WCDMA	–	–18.1	–	dBm
$\pi/4$ DPSK (2 Mbps)^b					
698–716 MHz	WCDMA	–	–5.9	–	dBm
776–794 MHz	WCDMA	–	–5.9	–	dBm
824–849 MHz	GSM850	–	–8.4	–	dBm
824–849 MHz	WCDMA	–	–8	–	dBm
880–915 MHz	E-GSM	–	–8.6	–	dBm
880–915 MHz	WCDMA	–	–8.6	–	dBm
1710–1785 MHz	GSM1800	–	–14.4	–	dBm
1710–1785 MHz	WCDMA	–	–14.3	–	dBm
1850–1910 MHz	GSM1900	–	–15.2	–	dBm
1850–1910 MHz	WCDMA	–	–14.6	–	dBm
1880–1920 MHz	TD-SCDMA	–	–16.3	–	dBm
1920–1980 MHz	WCDMA	–	–15.2	–	dBm
2010–2025 MHz	TD-SCDMA	–	–16.7	–	dBm
2500–2570 MHz	WCDMA	–	–16.7	–	dBm

Not Recommended for New Designs

Table 28: Bluetooth Receiver RF Specifications (Cont.)

<i>Parameter</i>	<i>Conditions</i>	<i>Minimum</i>	<i>Typical</i>	<i>Maximum</i>	<i>Unit</i>
8DPSK (3 Mbps)^c					
698–716 MHz	WCDMA	–	–7.5	–	dBm
776–794 MHz	WCDMA	–	–7.5	–	dBm
824–849 MHz	GSM850	–	–10.0	–	dBm
824–849 MHz	WCDMA	–	–9.7	–	dBm
880–915 MHz	E-GSM	–	–10.0	–	dBm
880–915 MHz	WCDMA	–	–9.7	–	dBm
1710–1785 MHz	GSM1800	–	–16.3	–	dBm
1710–1785 MHz	WCDMA	–	–15.6	–	dBm
1850–1910 MHz	GSM1900	–	–17.4	–	dBm
1850–1910 MHz	WCDMA	–	–16.9	–	dBm
1880–1920 MHz	TD-SCDMA	–	–18.1	–	dBm
1920–1980 MHz	WCDMA	–	–17.5	–	dBm
2010–2025 MHz	TD-SCDMA	–	–19.1	–	dBm
2500–2570 MHz	WCDMA	–	–18.5	–	dBm
Spurious Emissions					
30 MHz–1 GHz		–	–	–62	dBm
1–12.75 GHz		–	–	–47	dBm
851–894 MHz		–	–147	–	dBm/Hz
925–960 MHz		–	–147	–	dBm/Hz
1805–1880 MHz		–	–147	–	dBm/Hz
1930–1990 MHz		–	–147	–	dBm/Hz
2110–2170 MHz		–	–147	–	dBm/Hz

- The maximum value represents the actual Bluetooth specification required for Bluetooth qualification as defined in the version 4.0 specification.
- Bluetooth reference level for the wanted signal at the Bluetooth Chip port = –84.5 dBm.
- Bluetooth reference level for the wanted signal at the Bluetooth chip port = –79.5 dBm.

Table 29: Bluetooth Transmitter RF Specifications

Parameter	Conditions	Minimum	Typical	Maximum	Unit
Note: The specifications in this table are measured at the Chip port output unless otherwise specified.					
General					
Frequency range		2402	–	2480	MHz
Basic rate (GFSK) Tx power at Bluetooth		11.0	13.0	–	dBm
QPSK Tx Power at Bluetooth		8.0	10.0	–	dBm
8PSK Tx Power at Bluetooth		8.0	10.0	–	dBm
Power control step		2	4	6	dB
Note: Output power is with TCA and TSSI enabled.					
GFSK In-Band Spurious Emissions					
–20 dBc BW	–	–	–	1	MHz
EDR In-Band Spurious Emissions					
1.0 MHz < M – N < 1.5 MHz	M – N = the frequency range	–	–	–26.0	dBc
1.5 MHz < M – N < 2.5 MHz	for which the spurious	–	–	–20.0	dBm
M – N ≥ 2.5 MHz	emission is measured relative to the transmit center frequency.	–	–	–40.0	dBm
Out-of-Band Spurious Emissions					
30 MHz to 1 GHz	–	–	–	–36.0 ^{a, b}	dBm
1 GHz to 12.75 GHz	–	–	–	–30.0 ^{b, c, d}	dBm
1.8 GHz to 1.9 GHz	–	–	–	–47.0	dBm
5.15 GHz to 5.3 GHz	–	–	–	–47.0	dBm
Rx LO Leakage					
2.4 GHz band	–	–	–90.0	–80.0	dBm
GPS Band Spurious Emissions					
Spurious emissions	–	–	–150	–127	dBm
Out-of-Band Noise Floor^e					
65–108 MHz	FM Rx	–	–140	–	dBm/Hz
776–794 MHz	CDMA2000	–	–140	–	dBm/Hz
869–960 MHz	cdmaOne, GSM850	–	–140	–	dBm/Hz
925–960 MHz	E-GSM	–	–140	–	dBm/Hz
1570–1580 MHz	GPS	–	–140	–	dBm/Hz
1805–1880 MHz	GSM1800	–	–140	–	dBm/Hz
1930–1990 MHz	GSM1900, cdmaOne, WCDMA	–	–140	–	dBm/Hz
2110–2170 MHz	WCDMA	–	–140	–	dBm/Hz

Not Recommended for New Designs

- The maximum value represents the value required for Bluetooth qualification as defined in the v4.0 specification.
- The spurious emissions during Idle mode are the same as specified in [Table 29 on page 114](#).
- Specified at the Bluetooth Antenna port.
- Meets this specification using a front-end band-pass filter.
- Transmitted power in cellular and FM bands at the Bluetooth Antenna port. See [Figure 39 on page 110](#) for location of the port.

Table 30: Local Oscillator Performance

Parameter	Minimum	Typical	Maximum	Unit
LO Performance				
Lock time	–	72	–	μs
Initial carrier frequency tolerance	–	±25	±75	kHz
Frequency Drift				
DH1 packet	–	±10	±25	kHz
DH3 packet	–	±10	±40	kHz
DH5 packet	–	±10	±40	kHz
Drift rate	–	5	20	kHz/50 μs
Frequency Deviation				
00001111 sequence in payload ^a	140	–	175	kHz
10101010 sequence in payload ^b	115	–	–	kHz
Channel spacing	–	1	–	MHz

- This pattern represents an average deviation in payload.
- Pattern represents the maximum deviation in payload for 99.9% of all frequency deviations.

Table 31: BLE RF Specifications

Parameter	Conditions	Minimum	Typical	Maximum	Unit
Freq range	–	2402		2480	MHz
Rx sense	GFSK, .1% BER, 1 Mbps	–	-95.0	–	dBm
Tx power ^a	–	–	8.5	–	dBm
Mod Char: delta f1 avg	–	225	–	275	KHz
Mod Char: delta f2 max ^b	–	99.9	–	–	%
Mod Char: ratio	–	0.8	–	–	%

- BLE Tx power can be increased to compensate for front-end losses such as BPF, diplexer, switch, etc.). The output is capped at 12 dBm out. The BLE Tx power at the antenna port cannot exceed the 10 dBm specification limit.
- At least 99.9% of all delta F2 max freq values recorded over 10 pkts must be greater than 185 kHz.

Section 17: FM Receiver Specifications



Note: Values in this data sheet are design goals and are subject to change based on the results of device characterization.

Unless otherwise stated, limit values apply for the conditions specified in [Table 25: “Environmental Ratings,” on page 107](#) and [Table 27: “Recommended Operating Conditions and DC Characteristics,” on page 108](#). Typical values apply for the following conditions:

- VBAT = 3.6V
- Ambient temperature +25°C

Table 32: FM Receiver Specifications

Parameter	Conditions ^a	Minimum	Typical	Maximum	Units
RF Parameters					
Operating frequency ^b	Frequencies inclusive	65	–	108	MHz
Sensitivity ^c	FM only	–	–0.5	–	dBμV EMF
	$\Delta f = 22.5$ kHz, $f_{\text{mod}} = 1$ kHz	–	0.95	–	μV EMF
	SNR ≥ 26 dB	–	–6.5	–	dBμV
Receiver adjacent channel selectivity ^{c,d}	Measured for 30 dB SNR at the audio output. Wanted Signal: 23 dBμV EMF (14.1 μV EMF), $\Delta f = 22.5$ kHz, $f_{\text{mod}} = 1$ kHz Interferer: $\Delta f = 22.5$ kHz, $f_{\text{mod}} = 1$ kHz				
	At ± 200 kHz	–	51	–	dB
	At ± 400 kHz	–	62	–	dB
Intermediate signal plus noise-to-noise ratio (S+N)/N, stereo ^c	$V_{\text{in}} = 20$ dBμV EMF (10 μV EMF), $\Delta f = 22.5$ kHz, $f_{\text{mod}} = 1$ kHz BAF = 300 Hz to 15 kHz, A-weighted mono	45	53	–	dB

Table 32: FM Receiver Specifications (Cont.)

Parameter	Conditions^a	Minimum	Typical	Maximum	Units
Intermodulation performance ^{c,d}	Blocker level increased until desired at 30 dB SNR Wanted Signal: 33 dB μ V EMF (45 μ V EMF), $\Delta f = 22.5$ kHz, $f_{mod} = 1$ kHz Modulated Interferer: At $f_{Wanted} \pm 400$ kHz and ± 4 MHz $\Delta f = 22.5$ kHz, $f_{mod} = 1$ kHz CW Interferer: At $f_{Wanted} \pm 800$ kHz and ± 8 MHz	–	55	–	dBc
AM suppression, mono ^c	$V_{in} = 23$ dB μ V EMF (14.1 μ V EMF), $\Delta f = 22.5$ kHz, $f_{mod} = 1$ kHz AM at 400 Hz with $m = 0.3$ No A-weighted or any other filtering applied	40	–	–	dB
RDS					
RDS sensitivity ^{e,f}	$\Delta f = 32$ kHz, $f_{mod} = 1$ kHz, Δf Pilot = 7.5 kHz	–	16	–	dB μ V EMF
	95% of blocks decoded with no errors after correction	–	6.3	–	μ V EMF
	RDS deviation = 1.2 kHz	–	10	–	dB μ V
	RDS deviation = 2 kHz	–	12	–	dB μ V EMF
		–	4	–	μ V EMF
RDS selectivity ^f	Wanted Signal: 33 dB μ V EMF (45 μ V EMF), 2 kHz RDS deviation $\Delta f = 32$ kHz, $f_{mod} = 1$ kHz, Δf Pilot = 7.5 kHz Interferer: $\Delta f = 40$ kHz, $f_{mod} = 1$ kHz Interferer level for 95% of blocks decoded with no errors after correction				
	± 200 kHz	–	49	–	dB
	± 300 kHz	–	52	–	dB
	± 400 kHz	–	52	–	dB
RF Input					
RF input impedance		1.5	–	–	k Ω
Antenna tuning capacitor		2.5	–	30	pF

Table 32: FM Receiver Specifications (Cont.)

Parameter	Conditions^a	Minimum	Typical	Maximum	Units
Maximum input level ^c	$\Delta f = 22.5$ kHz, $f_{\text{mod}} = 1$ kHz SNR > 26 dB	–	105	–	dB μ V EMF
		–	178	–	mV EMF
		–	99	–	dB μ V
RF conducted emissions	Local oscillator breakthrough measured on the reference port	–	–	–55	dBm
	GPS	–	–	–90	dBm
	869–894, 925–960 MHz, 1805–1880 MHz, 1930–1990 MHz				

Table 32: FM Receiver Specifications (Cont.)

Parameter	Conditions^a	Minimum	Typical	Maximum	Units
RF blocking levels at the FM antenna input 40 dB SNR (assumes a 50Ω at the radio input and excludes spurs)	GSM850, E-GSM (standard/edge), BW = 0.2 MHz, 824–849, 880-915	0	–	–	dBm
	GSM DCS 1800, PCS 1900 (standard, edge), BW = 0.2 MHz, 1710–1785, 1850–1910	–5	–	–	dBm
	WCDMA - II(I), III(IV,X), BW = 5MHz, 1850–1980 (1920-1980), 1710–1785 (1710–1755, 1710–1770),	–5	–	–	dBm
	WCDMA - V(VI), VIII, XII, XIII, XIV, BW=5 MHz, 824–849 (830–840), 880–915,	–5	–	–	dBm
	CDMA2000, CDMA One, 1.25 MHz, 824–849, 887–925, 776–794	–10	–	–	dBm
	CDMA2000, CDMA One, BW= 1.25MHz, 1850–1910, 1750–1780, 1920–1980	–5	–	–	dBm
	BT, BW = 1 MHz, 2402–2480	–20	–	–	dBm
	WLAN-g/b, BW = 20 MHz, 2400–2483.5	–20	–	–	dBm
	WLAN-a, BW = 20M Hz, 4915–5825	–	–	–	dBm
Tuning					
Frequency step	–	10	–	–	kHz

Table 32: FM Receiver Specifications (Cont.)

Parameter	Conditions^a	Minimum	Typical	Maximum	Units
Settling time	Single frequency switch in any direction to a frequency within the bands 88–108 MHz or 76–90 MHz. Time measured to within 5 kHz of the final frequency.	–	150	–	μs
Search time	Total time for an automatic search to sweep from 88–108 MHz or 76–90 MHz (and reverse direction) assuming no channels found.	–	–	8	sec
General Audio					
Audio output level ^g	V _{in} = 66 dBμV EMF (2 mV EMF) Δf = 22.5 kHz, f _{mod} = 1 kHz, Δf Pilot = 6.75 kHz	–14.5	–	–12.5	dBFS
Maximum audio output level ^h	V _{in} = 66 dBμV EMF (2 mV EMF), Δf = 100 kHz, f _{mod} = 1 kHz, Δf Pilot = 6.75 kHz	–	–	0	dBFS
Soft mute attenuation and start level	Muting is performed dynamically proportional to the FM wanted input signal C/N. The muting characteristic is fully programmable. See “Audio Features” on page 62 for further details.				
Maximum signal plus noise-to-noise ratio (S+N)/N, mono ⁱ	V _{in} = 66 dBμV EMF (2 mV EMF) Δf = 22.5 kHz, f _{mod} = 1 kHz	–	69	–	dB
Maximum signal plus noise-to-noise ratio (S+N)/N, stereo ^g	V _{in} = 66 dBμV EMF (2 mV EMF) Δf = 22.5 kHz, f _{mod} = 1 kHz, Δf Pilot = 6.75 kHz	–	64	–	dB
Total harmonic distortion, mono	V _{in} = 66 dBμV EMF (2 mV EMF), Δf = 75 kHz, f _{mod} = 400 Hz	–	–	0.8	%
	Δf = 75 kHz, f _{mod} = 1 kHz	–	–	0.8	%
	Δf = 75 kHz, f _{mod} = 3 kHz	–	–	0.8	%
	Δf = 100 kHz, f _{mod} = 1 kHz,	–	–	1.0	%
Total harmonic distortion, stereo	V _{in} = 66 dBμV EMF (2 mV EMF) Δf = 67.5 kHz, f _{mod} = 1 kHz, Δf Pilot=7.5kHz, L=R	–	–	1.5	%
Audio spurious products ⁱ	V _{in} = 66 dBμV EMF (2 mV EMF), Δf = 22.5 kHz, f _{mod} = 1 kHz, Range from 300 Hz to 15 kHz, with respect to 1 kHz tone	–	–	–60	dBc

Table 32: FM Receiver Specifications (Cont.)

Parameter	Conditions^a	Minimum	Typical	Maximum	Units
Audio bandwidth, upper (–3 dB point)	Vin = 66 dBμV EMF (2 mV EMF) Δf = 8 kHz, for 50 μs	15	–	–	kHz
Audio bandwidth, lower (–3 dB point)		–	–	20	Hz
Audio in-band ripple	100 Hz to 13 kHz, Vin = 66 dBμV EMF (2 mV EMF) Δf = 8 kHz, for 50 μs	–0.5	–	0.5	dB
Deemphasis time constant tolerance	With respect to 50 μs and 75 μs	–	–	±5	%
RSSI range	With 1 dB resolution and ±5 dB accuracy at room temp	3	–	83	dBμV EMF
		1.41	–	1.41E+04	μV EMF
		–3	–	77	dBuV
Stereo Decoder					
Stereo channel separation	Forced Stereo mode Vin = 66 dBμV EMF(2 mV EMF), Δf = 67.5kHz, fmod = 1kHz, Δf Pilot = 6.75kHz R = 0, L = 1	–	48	–	dB
Mono Stereo Blend and Switching	Blending and switching is dynamically proportional to the FM wanted input signal C/N. The blending and switching characteristics are fully programmable. “Audio Features” on page 62 for further details.				
Pilot suppression	Vin = 66 dBμV EMF (2 mV EMF), Δf = 75 kHz, fmod = 1 kHz,	46	–	–	dB
Pause Detection					
Audio level at which a pause is detected	Relative to 1kHz tone, Δf = 22.5 kHz	–	–	–	–
	4 values in 3 dB steps	–21	–	–12	dB
Audio pause duration	4 values	20	–	40	ms

a. The following conditions are applied to all relevant tests unless otherwise indicated: Preemphasis and deemphasis of 50 μs, R = L for mono, BAF = 300 Hz to 15 kHz, A-weighted filtering applied.

- b. Please contact Broadcom regarding applications that will operate between 65 and 76 MHz.
- c. Wanted signal: $\Delta f = 22.5$ kHz, $f_{\text{mod}} = 1$ kHz.
- d. Interferer: $\Delta f = 22.5$ kHz, $f_{\text{mod}} = 1$ kHz.
- e. RDS sensitivity numbers are for 87.5 to 108 MHz only.
- f. $V_{\text{in}} = \Delta f = 32$ kHz, $f_{\text{mod}} = 1$ kHz, $\Delta f_{\text{Pilot}} = 7.5$ kHz, 95% of blocks decoded with no errors after correction.
- g. $V_{\text{in}} = 66$ dB μ V EMF (2 mV EMF), $\Delta f = 22.5$ kHz, $f_{\text{mod}} = 1$ kHz, $\Delta f_{\text{Pilot}} = 6.75$ kHz.
- h. $V_{\text{in}} = 66$ dB μ V EMF (2 mV EMF), $\Delta f = 100$ kHz, $f_{\text{mod}} = 1$ kHz, $\Delta f_{\text{Pilot}} = 6.75$ kHz.
- i. $V_{\text{in}} = 66$ dB μ V EMF (2 mV EMF), $\Delta f = 22.5$ kHz, $f_{\text{mod}} = 1$ kHz.

Not Recommended for New Designs

Section 18: WLAN RF Specifications

Introduction

The BCM43241 includes an integrated dual-band direct conversion radio that supports either the 2.4 GHz band or the 5 GHz band. This section describes the RF characteristics of the 2.4 GHz and 5 GHz portions of the radio.

 **Note:** Values in this data sheet are design goals and are subject to change based on the results of device characterization.

Unless otherwise stated, limit values apply for the conditions specified in [Table 25: “Environmental Ratings,” on page 107](#) and [Table 27: “Recommended Operating Conditions and DC Characteristics,” on page 108](#). Typical values apply for the following conditions:

- VBAT = 3.6V
- Ambient temperature +25°C

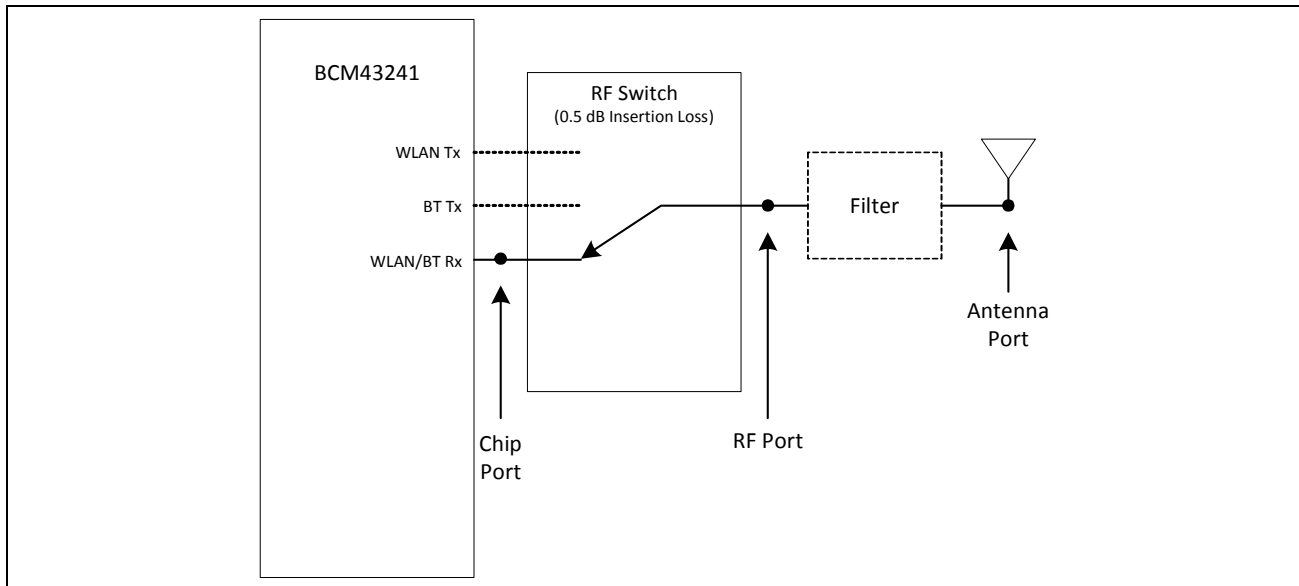



Figure 40: Port Locations

 **Note:** All WLAN specifications are measured at the chip port, unless otherwise specified.

Not Recommended for New Designs

2.4 GHz Band General RF Specifications

Table 33: 2.4 GHz Band General RF Specifications

<i>Item</i>	<i>Condition</i>	<i>Minimum</i>	<i>Typical</i>	<i>Maximum</i>	<i>Unit</i>
Tx/Rx switch time	Including TX ramp down	–	–	5	μs
Rx/Tx switch time	Including TX ramp up	–	–	2	μs
Power-up and power-down ramp time	DSSS/CCK modulations	–	–	< 2	μs

Not Recommended for New Designs

WLAN 2.4 GHz Receiver Performance Specifications



Note: The specifications in [Table 34](#) are measured at the chip port, unless otherwise specified.

Table 34: WLAN 2.4 GHz Receiver Performance Specifications

Parameter	Condition/Notes	Minimum	Typical	Maximum	Unit
Frequency range	–	2400	–	2500	MHz
SISO RX sensitivity (8% PER for 1024 octet PSDU) ^a	1 Mbps DSSS	–	–99.0	–	dBm
	2 Mbps DSSS	–	–96.0	–	dBm
	5.5 Mbps DSSS	–	–94.2	–	dBm
	11 Mbps DSSS	–	–90.4	–	dBm
SISO RX sensitivity (10% PER for 1024 octet PSDU) ^a	6 Mbps OFDM	–	–94.0	–	dBm
	9 Mbps OFDM	–	–93.1	–	dBm
	12 Mbps OFDM	–	–91.7	–	dBm
	18 Mbps OFDM	–	–89.6	–	dBm
	24 Mbps OFDM	–	–85.6	–	dBm
	36 Mbps OFDM	–	–83	–	dBm
	48 Mbps OFDM	–	–77.7	–	dBm
MIMO RX sensitivity (10% PER for 1024 octet PSDU) ^a	6 Mbps OFDM	–	–95.0	–	dBm/core
	9 Mbps OFDM	–	–94.2	–	dBm/core
	12 Mbps OFDM	–	–93.5	–	dBm/core
	18 Mbps OFDM	–	–92.6	–	dBm/core
	24 Mbps OFDM	–	–88.6	–	dBm/core
	36 Mbps OFDM	–	–86	–	dBm/core
	48 Mbps OFDM	–	–80.7	–	dBm/core
	54 Mbps OFDM	–	–79.5	–	dBm/core
SISO RX sensitivity (10% PER for 4096 octet PSDU) ^{a,b} . Defined for default parameters: GF, 800 ns GI, and non-STBC.	20 MHz channel spacing for all MCS rates				
	MCS 7	–	–73.9	–	dBm
	MCS 6	–	–75.6	–	dBm
	MCS 5	–	–77	–	dBm
	MCS 4	–	–81.4	–	dBm
	MCS 3	–	–84.5	–	dBm
	MCS 2	–	–88.3	–	dBm
	MCS 1	–	–90.5	–	dBm
	MCS0	–	–92.5	–	dBm

Not Recommended for New Designs

Table 34: WLAN 2.4 GHz Receiver Performance Specifications (Cont.)

Parameter	Condition/Notes		Minimum	Typical	Maximum	Unit
MIMO RX sensitivity (10% PER for 4096 octet PSDU) ^{a,b} . Defined for default parameters: GF, 800 ns GI, and non-STBC.	20 MHz channel spacing for all MCS rates					
		MCS 15	–	–70.4	–	dBm (total)
		MCS 8	–	–90.1	–	dBm (total)
		MCS 7	–	–76.9	–	dBm/core
		MCS 6	–	–78.6	–	dBm/core
		MCS 5	–	–80	–	dBm/core
		MCS 4	–	–84.4	–	dBm/core
		MCS 3	–	–87.5	–	dBm/core
		MCS 2	–	–91.1	–	dBm/core
		MCS 1	–	–93.2	–	dBm/core
	MCS0	–	–94.0	–	dBm/core	
Blocking level for 1dB Rx sensitivity degradation (without external filtering) ^c	776–794 MHz	CDMA2000	–20	–	–	dBm
	824–849 MHz ^d	cdmaOne	–24.5	–	–	dBm
	824–849 MHz	GSM850	–20	–	–	dBm
	880–915 MHz	E-GSM	–18	–	–	dBm
	1710–1785 MHz	GSM1800	–20	–	–	dBm
	1850–1910 MHz	GSM1800	–22	–	–	dBm
	1850–1910 MHz	cdmaOne	–32	–	–	dBm
	1850–1910 MHz	WCDMA	–29	–	–	dBm
	1920–1980 MHz	WCDMA	–32	–	–	dBm
In-band static CW jammer immunity (fc – 8 MHz < f _{cw} < + 8 MHz)	Rx PER < 1%, 54 Mbps OFDM, 1000 octet PSDU for: (RxSens + 23 dB < Rxlevel < max input level)		–80	–	–	dBm
Input In-Band IP3 ^a	Maximum LNA gain		–	–15.5	–	dBm
	Minimum LNA gain		–	–1.5	–	dBm
Maximum Receive Level @ 2.4 GHz	@ 1, 2 Mbps (8% PER, 1024 octets)		–3.5	–	–	dBm
	@ 5.5, 11 Mbps (8% PER, 1024 octets)		–9.5	–	–	dBm
	@ 6–54 Mbps (10% PER, 1024 octets)		–19.5	–	–	dBm
	@ MCS0–7 rates (10% PER, 4095 octets)		–19.5	–	–	dBm
LPF 3 dB Bandwidth	–		9	–	10	MHz

Not Recommended for New Designs

Table 34: WLAN 2.4 GHz Receiver Performance Specifications (Cont.)

Parameter	Condition/Notes	Minimum	Typical	Maximum	Unit	
Adjacent channel rejection-DSSS (Difference between interfering and desired signal at 8% PER for 1024 octet PSDU with desired signal level as specified in Condition/Notes)	Desired and interfering signal 30 MHz apart					
	1 Mbps DSSS	-74 dBm	35	-	-	dB
	2 Mbps DSSS	-74 dBm	35	-	-	dB
	Desired and interfering signal 25 MHz apart					
	5.5 Mbps DSSS	-70 dBm	35	-	-	dB
	11 Mbps DSSS	-70 dBm	35	-	-	dB
Adjacent channel rejection-OFDM (Difference between interfering and desired signal (25 MHz apart) at 10% PER for 1024 octet PSDU with desired signal level as specified in Condition/Notes)	6 Mbps OFDM	-79 dBm	16	-	-	dB
	9 Mbps OFDM	-78 dBm	15	-	-	dB
	12 Mbps OFDM	-76 dBm	13	-	-	dB
	18 Mbps OFDM	-74 dBm	11	-	-	dB
	24 Mbps OFDM	-71 dBm	8	-	-	dB
	36 Mbps OFDM	-67 dBm	4	-	-	dB
	48 Mbps OFDM	-63 dBm	0	-	-	dB
	54 Mbps OFDM	-62 dBm	-1	-	-	dB
Adjacent channel rejection MCS0-7 (Difference between interfering and desired signal (25 MHz apart) at 10% PER for 4096 octet PSDU with desired signal level as specified in Condition/Notes)	MCS7	-61 dBm	-2	-	-	dB
	MCS6	-62 dBm	-1	-	-	dB
	MCS5	-63 dBm	0	-	-	dB
	MCS4	-67 dBm	4	-	-	dB
	MCS3	-71 dBm	8	-	-	dB
	MCS2	-74 dBm	11	-	-	dB
	MCS1	-76 dBm	13	-	-	dB
	MCS0	-79 dBm	16	-	-	dB
Maximum receiver gain	-	-	-	105	-	dB
Gain control step	-	-	-	3	-	dB
RSSI accuracy ^e	Range -98 dBm to -30 dBm	-5	-	5	-	dB
	Range above -30 dBm	-8	-	8	-	dB
Return loss	Z ₀ = 50Ω, across the dynamic range	6	10	-	-	dB
Receiver cascaded noise figure	At maximum gain	-	3.5	-	-	dB

- Derate by 1.5 dB for -30 °C to -10°C and 55°C to 85°C.
- Sensitivity degradations for alternate settings in MCS modes. MM: 0.5 dB drop, SGI: 2 dB drop, and STBC: 0.75 dB drop.
- The cellular standard listed for each band indicates the type of modulation used to generate the interfering signal in that band for the purpose of this test. It is not intended to indicate any specific usage of each band in any specific country.

Not Recommended for New Designs

- d. The blocking levels are valid for channels 1 to 11. (For higher channels, the performance may be lower due to third harmonic signals (3×824 MHz) falling within band.)
- e. The minimum and maximum values shown have a 95% confidence level.

Not Recommended for New Designs

WLAN 2.4 GHz Transmitter Performance Specifications



Note: The specifications in [Table 35](#) are measured at the chip port output, unless otherwise specified.

Table 35: WLAN 2.4 GHz Transmitter Performance Specifications

Parameter	Condition/Notes	Minimum	Typical	Maximum	Unit
Frequency range	–	2400	–	2500	MHz
Transmitted power in cellular and FM bands (at 18 dBm, ≥90% duty cycle, 1 Mbps CCK) ^a	76–108 MHz FM Rx	–	TBD	–	dBm/Hz
	776–794 MHz	–	TBD	–	dBm/Hz
	869–960 MHz CDMAOne, GSM850	–	TBD	–	dBm/Hz
	925–960 MHz E-GSM	–	TBD	–	dBm/Hz
	1570–1580 MHz GPS	–	TBD	–	dBm/Hz
	1805–1880 MHz GSM1800	–	TBD	–	dBm/Hz
	1930–1990 MHz GSM1900, CDMAOne, WCDMA	–	TBD	–	dBm/Hz
Harmonic level (with ≥90% duty cycle)	2110–2170 MHz WCDMA	–	TBD	–	dBm/Hz
	4.8–5.0 GHz 2nd harmonic	–	–	TBD	dBm/1 MHz
TX power at chip port for highest power level setting at 25°C, VBAT = 3.6V, spectral mask and EVM compliance ^{b, c}	7.2–7.5 GHz 3rd harmonic	–	–	TBD	dBm/1 MHz
	11b – 1 Mbps	–	20.5	–	dBm
	11g – 6 Mbps	–	19.5	–	dBm
	11g – 54 Mbps @ –25 dB EVM, single Tx chain	–	19.5	–	dBm
	11g – 54 Mbps @ –25 dB EVM, 2 TX chains, CDD	–	19	–	dBm
	MCS7 – HT20 @ –28 dB EVM, single TX chain	–	17.5	–	dBm
Phase noise	MCS7 – HT20 @ –28 dB EVM, 2SS	–	17	–	dBm
	37.4 MHz Crystal, Integrated from 10 kHz to 10 MHz	–	0.5	–	Degrees
Tx power control dynamic range	–	20	–	–	dB
Carrier suppression	–	15	–	–	dBc
Gain control step	–	–	0.25	–	dB
Return loss at Chip port Tx Z ₀ = 50Ω	–	4	6	–	dB

- The cellular standards listed indicate only typical usages of that band in some countries. Other standards may also be used within those bands.
- Derate power by 1.5 dB for –30°C to –10°C and 55°C to 85°C.

Not Recommended for New Designs

- c. Derate by 1 dB for PA_Vdd supply (direct supply to PA) of 3V.

Not Recommended for New Designs

WLAN 5 GHz Receiver Performance Specifications



Note: The specifications in [Table 36](#) are measured at the chip port input, unless otherwise specified.

Table 36: WLAN 5 GHz Receiver Performance Specifications

Parameter	Condition/Notes	Minimum	Typical	Maximum	Unit
Frequency range	–	4900	–	5845	MHz
SISO RX sensitivity (10% PER for 1000 octet PSDU) ^a	6 Mbps OFDM	–	–92.4	–	dBm
	9 Mbps OFDM	–	–91.1	–	dBm
	12 Mbps OFDM	–	–89.7	–	dBm
	18 Mbps OFDM	–	–87.6	–	dBm
	24 Mbps OFDM	–	–83.6	–	dBm
	36 Mbps OFDM	–	–81	–	dBm
	48 Mbps OFDM	–	–76.2	–	dBm
	54 Mbps OFDM	–	–75.1	–	dBm
MIMO RX sensitivity (10% PER for 1000 octet PSDU) ^a	6 Mbps OFDM	–	–93.5	–	dBm/core
	9 Mbps OFDM	–	–93	–	dBm/core
	12 Mbps OFDM	–	–91.7	–	dBm/core
	18 Mbps OFDM	–	–90.6	–	dBm/core
	24 Mbps OFDM	–	–86.6	–	dBm/core
	36 Mbps OFDM	–	–84	–	dBm/core
	48 Mbps OFDM	–	–79.2	–	dBm/core
	54 Mbps OFDM	–	–78.0	–	dBm/core
SISO RX sensitivity (10% PER for 4096 octet PSDU) ^a Defined for default parameters: GF, 800 ns GI, and non-STBC.	20 MHz channel spacing for all MCS rates				
	MCS 7	–	–71.9	–	dBm
	MCS 6	–	–73.6	–	dBm
	MCS 5	–	–75	–	dBm
	MCS 4	–	–79.4	–	dBm
	MCS 3	–	–82.5	–	dBm
	MCS 2	–	–86.3	–	dBm
	MCS 1	–	–88.5	–	dBm
	MCS 0	–	–90.5	–	dBm

Not Recommended for New Designs

Table 36: WLAN 5 GHz Receiver Performance Specifications (Cont.)

Parameter	Condition/Notes	Minimum	Typical	Maximum	Unit
MIMO RX sensitivity (10% PER for 4096 octet PSDU) ^a Defined for default parameters: GF, 800 ns GI, and non-STBC.	20 MHz channel spacing for all MCS rates				
	MCS 15	–	–69.0	–	dBm (total)
	MCS 8	–	–89.0	–	dBm (total)
	MCS 7	–	–74.9	–	dBm/core
	MCS 6	–	–76.6	–	dBm/core
	MCS 5	–	–78	–	dBm/core
	MCS 4	–	–82.4	–	dBm/core
	MCS 3	–	–85.5	–	dBm/core
	MCS 2	–	–89.3	–	dBm/core
	MCS 1	–	–91.2	–	dBm/core
MCS 0	–	–92.5	–	dBm/core	
SISO RX sensitivity (10% PER for 4096 octet PSDU) ^a Defined for default parameters: GF, 800 ns GI, and non-STBC.	40 MHz channel spacing for all MCS rates				
	MCS 7	–	–69.4	–	dBm
	MCS 6	–	–71.1	–	dBm
	MCS 5	–	–72.5	–	dBm
	MCS 4	–	–77	–	dBm
	MCS 3	–	–80	–	dBm
	MCS 2	–	–83.8	–	dBm
	MCS 1	–	–86	–	dBm
	MCS 0	–	–88.1	–	dBm
MIMO RX sensitivity (10% PER for 4096 octet PSDU) ^a Defined for default parameters: GF, 800 ns GI, and non-STBC.	40 MHz channel spacing for all MCS rates				
	MCS 15	–	–67.0	–	dBm (total)
	MCS 8	–	–86.5	–	dBm (total)
	MCS 7	–	–71.9	–	dBm/core
	MCS 6	–	–73.7	–	dBm/core
	MCS 5	–	–75.1	–	dBm/core
	MCS 4	–	–79.6	–	dBm/core
	MCS 3	–	–82.7	–	dBm/core
	MCS 2	–	–86.5	–	dBm/core
	MCS 1	–	–88.6	–	dBm/core
MCS 0	–	–90.4	–	dBm/core	

Not Recommended for New Designs

Table 36: WLAN 5 GHz Receiver Performance Specifications (Cont.)

Parameter	Condition/Notes		Minimum	Typical	Maximum	Unit
Blocking level for 1 dB Rx Sensitivity degradation (without external filtering) ^b	776–794 MHz	CDMA2000	–21	–	–	dBm
	824–849 MHz	CDMAOne	–20	–	–	dBm
	824–849 MHz	GSM850	–12	–	–	dBm
	880–915 MHz	E-GSM	–12	–	–	dBm
	1710–1785 MHz	GSM1800	–15	–	–	dBm
	1850–1910 MHz	GSM1800	–15	–	–	dBm
	1850–1910 MHz	CDMAOne	–20	–	–	dBm
	1850–1910 MHz	WCDMA	–24	–	–	dBm
	1920–1980 MHz	WCDMA	–24	–	–	dBm
Input In-Band IP ₃ ^a	Maximum LNA gain		–	–15.5	–	dBm
	Minimum LNA gain		–	–1.5	–	dBm
Maximum receive level @ 5.24 GHz	@ 6, 9, 12 Mbps		–29.5	–	–	dBm
	@ 18, 24, 36, 48, 54 Mbps		–29.5	–	–	dBm
LPF 3 dB bandwidth	–		9	–	18	MHz
Adjacent channel rejection (Difference between interfering and desired signal (20 MHz apart) at 10% PER for 1000 octet PSDU with desired signal level as specified in Condition/Notes)	6 Mbps OFDM	–79 dBm	16	–	–	dB
	9 Mbps OFDM	–78 dBm	15	–	–	dB
	12 Mbps OFDM	–76 dBm	13	–	–	dB
	18 Mbps OFDM	–74 dBm	11	–	–	dB
	24 Mbps OFDM	–71 dBm	8	–	–	dB
	36 Mbps OFDM	–67 dBm	4	–	–	dB
	48 Mbps OFDM	–63 dBm	0	–	–	dB
	54 Mbps OFDM	–62 dBm	–1	–	–	dB
Alternate adjacent channel rejection (Difference between interfering and desired signal (40 MHz apart) at 10% PER for 1000 ^c octet PSDU with desired signal level as specified in Condition/Notes)	6 Mbps OFDM	–78.5 dBm	32	–	–	dB
	9 Mbps OFDM	–77.5 dBm	31	–	–	dB
	12 Mbps OFDM	–75.5 dBm	29	–	–	dB
	18 Mbps OFDM	–73.5 dBm	27	–	–	dB
	24 Mbps OFDM	–70.5 dBm	24	–	–	dB
	36 Mbps OFDM	–66.5 dBm	20	–	–	dB
	48 Mbps OFDM	–62.5 dBm	16	–	–	dB
	54 Mbps OFDM	–61.5 dBm	15	–	–	dB
Maximum receiver gain	–		–	100	–	dB
	–		–	3	–	dB
RSSI accuracy ^d	Range –98 dBm to –30 dBm		–5	–	5	dB
	Range above –30 dBm		–8	–	8	dB

Not Recommended for New Designs

Table 36: WLAN 5 GHz Receiver Performance Specifications (Cont.)

Parameter	Condition/Notes	Minimum	Typical	Maximum	Unit
Return loss	$Z_0 = 50\Omega$	6	10	–	dB
Receiver cascaded noise figure	At maximum gain	–	5.0	–	dB

- a. Derate by 1.5 dB for -30°C to -10°C and 55°C to 85°C .
- b. The cellular standard listed for each band indicates the type of modulation used to generate the interfering signal in that band for the purpose of this test. It is not intended to indicate any specific usage of each band in any specific country.
- c. For 65 Mbps, the size is 4096.
- d. The minimum and maximum values shown have a 95% confidence level.

Not Recommended for New Designs

WLAN 5 GHz Transmitter Performance Specifications



Note: The specifications in [Table 37](#) are measured at the chip port, unless otherwise specified.

Table 37: WLAN 5 GHz Transmitter Performance Specifications

Parameter	Condition/Notes	Minimum	Typical	Maximum	Unit
Frequency range	–	4900	–	5845	MHz
Transmitted power in cellular and FM bands (at 18 dBm) ^a , >90% duty cycle, OFDM	76–108 MHz FM Rx	–	TBD	–	dBm/Hz
	776–794 MHz –	–	TBD	–	dBm/Hz
	869–960 MHz CDMAOne, GSM850	–	TBD	–	dBm/Hz
	925–960 MHz E-GSM	–	TBD	–	dBm/Hz
	1570–1580 MHz GPS	–	TBD	–	dBm/Hz
	1805–1880 MHz GSM1800	–	TBD	–	dBm/Hz
	1930–1990 MHz GSM1900, CDMAOne, WCDMA	–	TBD	–	dBm/Hz
	2110–2170 MHz WCDMA	–	TBD	–	dBm/Hz
Harmonic level (at 18 dBm)	2400–2483 MHz BT/WLAN	–	TBD	–	dBm/Hz
	9.8–11.570 GHz 2nd harmonic	–	TBD	–	dBm/MHz
TX power at chip port for highest power level setting at 25°C, VBAT = 3.6V, spectral mask and EVM compliance ^b	11a – 6 Mbps – single TX chain	–	18	–	dBm
	11a – 6 Mbps – 2 TX chains – CDD	–	18	–	dBm
	11a – 54 Mbps @ –25 dB EVM – single TX chain	–	18	–	dBm
	11a – 54 Mbps @ –25 dB EVM – 2 TX chains – CDD	–	18	–	dBm
	MCS7 – HT20 @ –28 dB EVM – single TX chain	–	16	–	dBm
	MCS7 – HT20 @ –28 dB EVM – 2SS	–	16	–	dBm
	MCS7 – HT40 @ –28 dB EVM – single TX chain	–	16	–	dBm
	MCS7 – HT40 @ –28 dB EVM – 2SS	–	16	–	dBm
Phase noise	37.4 MHz Crystal, Integrated from 10 kHz to 10 MHz	–	0.8	1 ^c	Degrees
Tx power control dynamic range	–	20	–	–	dB
Carrier suppression	–	15	–	–	dBc
Gain control step	–	–	0.25	–	dB

Not Recommended for New Designs

Table 37: WLAN 5 GHz Transmitter Performance Specifications (Cont.)

Parameter	Condition/Notes	Minimum	Typical	Maximum	Unit
Return loss	$Z_o = 50\Omega$	–	6	–	dB

- The cellular standards listed indicate only typical usages of that band in some countries. Other standards may also apply to usages within these bands.
- Derate power by 1.5 dB for -30°C to -10°C and 55°C to 85°C .
- Applicable for channels 5550 MHz, 5755 MHz, and 5805 MHz.

General Spurious Emissions Specifications

Table 38: General Spurious Emissions Specifications

Parameter	Condition/Notes	Min	Typ	Max	Unit
Frequency range	–	2400	–	2500	MHz

General Spurious Emissions

Tx Emissions	30 MHz < f < 1 GHz	RBW = 100 kHz	–	–	TBD	dBm
	1 GHz < f < 12.75 GHz	RBW = 1 MHz	–	–	TBD	dBm
	1.8 GHz < f < 1.9 GHz	RBW = 1 MHz	–	–	TBD	dBm
	5.15 GHz < f < 5.3 GHz	RBW = 1 MHz	–	–	TBD	dBm
Rx/standby Emissions	30 MHz < f < 1 GHz	RBW = 100 kHz	–	–78	–63	dBm
	1 GHz < f < 12.75 GHz	RBW = 1 MHz	–	–68.5 ^a	–53	dBm
	1.8 GHz < f < 1.9 GHz	RBW = 1 MHz	–	–96	–53	dBm
	5.15 GHz < f < 5.3 GHz	RBW = 1 MHz	–	–96	–53	dBm

- For frequencies other than 3.2 GHz, the emissions value is -96 dBm. The value presented in table is the result of LO leakage at 3.2 GHz.

Section 19: Internal Regulator Electrical Specifications



Note: Values in this data sheet are design goals and are subject to change based on the results of device characterization.

Functional operation is not guaranteed outside of the specification limits provided in this section.

Core Buck Switching Regulator

Table 39: Core Buck Switching Regulator (CBUCK) Specifications

Specification	Notes	Min	Typ	Max	Units
Input Supply Voltage VBAT (DC)	DC voltage range inclusive of disturbances.	2.3	3.6	4.8 ^a	V
PWM mode switching frequency	Forced PWM without FLL enabled	2.8	4	5.2	MHz
	Forced PWM with FLL enabled	3.6	4	4.4	MHz
PWM output current	–	–	–	600	mA
Output Current Limit	Peak inductor current	1100	1400	–	mA
Output Voltage Range	Programmable, 30 mV steps Default = 1.35V	1.2	1.35	1.5	V
PWM Output Voltage DC Accuracy	Includes load and line regulation. Forced PWM mode	–4	–	4	%
PWM ripple voltage, static	Measure with 20 MHz bandwidth limit. Static Load. Max Ripple based on VBAT = 3.6V, Vout = 1.35V, Fsw = 4 MHz, 2.2 μH inductor L > 1.05 μH, Cap+Board total-ESR < 20 mΩ, Cout > 1.9 μF, ESL < 200 pH	–	7	20	mVpp
PWM Mode Peak Efficiency	Peak Efficiency at 200 mA load Vout = 1.35V, VBAT = 3.6V at 25°C, Fsw = 4 MHz 2.2 μH inductor 0806 with DCR = 0.11Ω ±25% and ACR <1Ω at 4 MHz	78	86	–	%
PFM Mode Efficiency	10 mA load current Vout = 1.35V, VBAT = 3.6V at 25°C, Cap+Board total-ESR < 20 mΩ, Cout = 4.7 μF, ESL < 200 pH FLL = OFF 0806-size, L = 2.2 μH, DCR = 110 mΩ ±25%, ACR < 2Ω	70	81	–	%

Not Recommended for New Designs

Table 39: Core Buck Switching Regulator (CLOCK) Specifications (Cont.)

Specification	Notes	Min	Typ	Max	Units
LPOM Efficiency	1 mA load current, $V_{out} = 1.35V$, $V_{BAT} = 3.6V$ at $25^{\circ}C$, Cap+Board total-ESR < 20 m Ω , $C_{out} = 4.7 \mu F$, ESL < 200 pH FLL = OFF L = 2.2 μH , DCR = 240 m Ω $\pm 25\%$, ACR < 2 Ω	62	72	–	%
Start-up time from power down	VIO already ON and steady. Time from REG_ON rising edge to CLDO reaching 1.2V	–	674	850	μs
External Inductor	0806 with DCR = 0.11 Ω $\pm 25\%$ and ACR <1 Ω	–	2.2	–	μH
External Output Capacitor	Ceramic, X5R, 0402, ESR <30 m Ω at 4 MHz, $\pm 20\%$, 6.3V	2 ^b	4.7	10 ^c	μF
External Input Capacitor	For SR_VDDBATP5V pin, Ceramic, X5R, 0603, ESR < 30 m Ω at 4 MHz, $\pm 20\%$, 6.3V, 4.7 μF	0.67 ^b	4.7	–	μF
Input Supply Voltage Ramp-Up Time 0 to 4.3V		40	–	100,000	μs

- The maximum continuous supply voltage is 4.8V. Brief spikes above 4.8V can be tolerated. Specifically, voltages as high as 5.5V for up to 10 seconds cumulative duration over the lifetime of the device are allowed. Voltages as high as 5.0V for up to 250 seconds cumulative duration over the lifetime of the device are allowed.
- Minimum capacitor value refers to the residual capacitor value after taking into account the part-to-part tolerance, DC-bias, temperature, and aging.
- Total capacitance includes those capacitors connected at the far end of the active load.

Not Recommended for New Designs

3.3V LDO (LDO3P3)

Table 40: LDO3P3 Specifications

Specification	Notes	Min	Typ	Max	Units
Input Supply Voltage	Min = $V_o + 0.15V = 3.45V$ (for $V_o = 3.3V$) dropout voltage requirement must be met under maximum load for performance specifications.	2.3	3.6	4.8	V
Output current	–	0.1	–	125	mA
Output Voltage, V_o	Default = 3.3V	2.4	3.3	3.4	V
Dropout Voltage	At max load.	–	–	150	mV
Output Voltage DC Accuracy	Includes Line/Load regulation. Load > 0.1 mA	–5	–	+5	%
Quiescent Current	No load	–	8	16	μA
	Max load	–	1000	1200	μA
Line Regulation	V_{in} from ($V_o + 0.15V$) to 4.8V, max load	-0.2	–	3.5	mV/V
Load Regulation	Load from 1 mA to 125 mA, $V_{in} = 3.6V$	–	0.3	0.45	mV/mA
PSRR	$V_{BAT} \geq 3.6V$, $V_o = 3.3V$, $C_o = 2.2 \mu F$, Max load, 100 Hz to 100 kHz	20	–	–	dB
LDO Turn-ON time	Chip already powered up.	–	–	150	μs
External Output Capacitor, C_o	Ceramic, X5R, 0402, (ESR: 5m–240 m Ω), $\pm 10\%$, 10V	0.7 ^a	2.2	4.7	μF
External Input Capacitor	For SR_VDDBATA5V pin (shared with Bandgap) Ceramic, X5R, 0402, $\pm 10\%$, 10V. Not needed if sharing VBAT capacitor 4.7 μF with SR_VDDBATP5V.	0.55 ^a	1	2.2	μF

- a. Minimum capacitor value refers to the residual capacitor value after taking into account the part-to-part tolerance, DC-bias, temperature, and aging.

CLDO

Table 41: CLDO Specifications

Specification	Notes	Min	Typ	Max	Units
Input Supply Voltage, V_{in}	Min $V_{in} = V_o + 0.15V = 1.35V$ (for $V_o = 1.2V$) dropout voltage requirement must be met under maximum load.	1.3	1.35	1.5	V
Output Current	–	0.2	–	300	mA
Output Voltage, V_o	Programmable in 25 mV steps. Default = 1.2V	1.1	1.2	1.275	V
Dropout Voltage	At max load	–	–	150	mV
Output Voltage DC Accuracy	Includes line/load regulation	–4	–	+4	%
Quiescent Current	No load	–	24	–	μA
	Max load	–	2100	–	μA
Line Regulation	V_{in} from ($V_o + 0.15V$) to 1.5V, maximum load	–	–	5	mV/V
Load Regulation	Load from 1 mA to 300 mA; $V_{in} \geq (V_o + 0.15V)$	–	0.025	0.045	mV/mA
PSRR	@1 kHz, $V_{in} \geq V_o + 0.15V$, $C_o = 4.7 \mu F$	20	–	–	dB
Start-up Time of PMU	VIO up and steady. Time from the REG_ON rising edge to the CLDO reaching 99% of V_o	–	550	850	μs
LDO Turn-on Time	LDO turn-on time when rest of the chip is up	–	140	180	μs
External Output Capacitor, C_o	Total ESR: 5 m Ω –240 m Ω	1.32 ^a	4.7	–	μF
External Input Capacitor	Only use an external input capacitor at the VDD_LDO pin if it is not supplied from CBUCK output.	–	1	2.2	μF

- a. Minimum capacitor value refers to the residual capacitor value after taking into account the part-to-part tolerance, DC-bias, temperature, and aging.

LNLDO2

Table 42: LNLDO2 Specifications

Specification	Notes	Min	Typ	Max	Units
Input Supply Voltage, V_{in}	Min $V_{in} = V_o + 0.15V = 1.35V$ (for $V_o = 1.2V$) dropout voltage requirement must be met under maximum load.	1.3	1.35	1.5	V
Output Current	–	–	–	150	mA
Output Voltage, V_o	Programmable in 25 mV steps. Default = 1.2V	1.1	1.2	1.275	V
Dropout Voltage	At maximum load	–	–	150	mV
Output Voltage DC Accuracy	includes Line/Load regulation	–4	–	+4	%
Quiescent Current	No load	–	44	–	μA
	Max load	–	970	990	μA
Line Regulation	V_{in} from ($V_o + 0.15V$) to 1.5V, max load	–	–	5.5	mV/V
Load Regulation	Load from 1 mA to 150 mA; $V_{in} \geq (V_o + 0.15V)$	–	0.025	0.045	mV/mA
Output Noise	@30 kHz, 60-150 mA load $C_o = 2.2 \mu F$	–	–	60	nV/rt Hz
	@100 kHz, 60-150 mA load $C_o = 2.2 \mu F$	–	–	35	nV/rt Hz
PSRR	@ 1kHz, Input > 1.35V, $C_o = 2.2 \mu F$, $V_o = 1.2V$	20	–	–	dB
LDO Turn-on Time	LDO turn-on time when rest of chip is up	–	140	180	μs
External Output Capacitor, C_o	Total ESR (trace/capacitor): 5 m Ω –240 m Ω	0.5 ^a	2.2	4.7	μF
External Input Capacitor	Only use an external input capacitor at the VDD_LDO pin if it is not supplied from CBUCK output.	–	1	2.2	μF

- a. Minimum capacitor value refers to the residual capacitor value after taking into account the part-to-part tolerance, DC-bias, temperature, and aging.

LNLDO1

Table 43: LNLDO1 Specifications

Specification	Notes	Min	Typ	Max	Units
Input Supply Voltage, V_{in}	Min $V_{in} = V_o + 0.15V = 1.35V$ (for $V_o = 1.2V$) dropout voltage requirement must be met under maximum load.	1.3	1.35	1.5	V
Output Current	–	0.2	–	325	mA
Output Voltage, V_o	Programmable in 25 mV steps. Default = 1.2V	1.1	1.2	1.275	V
Dropout Voltage	At maximum load	–	–	150	mV
Output Voltage DC Accuracy	includes Line/Load regulation	–4	–	+4	%
Quiescent Current	No load	–	88	–	μA
	Max load	–	2100	–	μA
Line Regulation	V_{in} from ($V_o + 0.15V$) to 1.5V, 300 mA load	–	–	+5	mV/V
Load Regulation	Load from 1 mA to 300 mA; $V_{in} \geq (V_o + 0.15V)$	–	0.025	0.045	mV/mA
Output Noise	@30 kHz, 60-325 mA load $C_o = 4.7 \mu F$	–	–	60	nV/rt Hz
	@100 kHz, 60-325 mA load $C_o = 4.7 \mu F$	–	–	30	nV/rt Hz
PSRR	@ 1kHz, Input > 1.35V, $C_o = 4.7 \mu F$, $V_o = 1.2V$	20	–	–	dB
Start-up Time of PMU	VIO up and steady. Time from REG_ON rise edge to LNLDO1 reaching 99% of V_o	–	550	850	μs
LDO Turn-on Time	LDO turn-on time when rest of chip is up	–	140	180	μs
External Output Capacitor, C_o	Total ESR (trace/capacitor): 5 m Ω –240 m Ω	1.32 ^a	4.7	–	μF
External Input Capacitor	Only use an external input capacitor at the VDD_LDO pin if it is not supplied from CBUCK output.	–	1	2.2	μF

- a. Minimum capacitor value refers to the residual capacitor value after taking into account the part-to-part tolerance, DC-bias, temperature, and aging.

Section 20: System Current Consumption



Note:

- Values in this data sheet are design goals and are subject to change based on the results of device characterization.
- Unless otherwise stated, these values apply for the conditions specified in [Table 27: “Recommended Operating Conditions and DC Characteristics,”](#) on page 108.

WLAN Current Consumption

The WLAN current consumption measurements are shown in [Table 44](#) and [Table 45](#) on page 144.

All values in the tables are with the Bluetooth core in reset (that is, Bluetooth and FM are off).

Table 44: BCM43241 WLAN Current Consumption 2.4 GHz

Parameter	Typical, Host I/F=SDIO		Unit
	VBAT=3.6V	VDDIO=1.8V	
OFF (WL_REG_ON = Low, BT_REG_ON = low)	3	3	μA
Sleep (Interbeacon sleep)	4.3	153	μA
IEEE PS mode DTIM=1	1100	153	μA
IEEE PS mode DTIM=3	367	153	μA
Listen Current (1x1, OCL)	57	0.026	mA
Listen Current (2x2)	77	0.026	mA
Continuous Rx mode 54 Mbps(1x1 SCD)	62	0.026	mA
Continuous Rx mode 54 Mbps(2x2 MRC)	80	0.026	mA
Continuous Rx mode MCS7 - HT 20(1x1 SCD)	62	0.026	mA
Continuous Rx mode MCS7 - HT 20(2x2 MRC)	80	0.026	mA
Continuous Rx mode MCS8 - HT 20(2x2)	76.6	0.026	mA
Continuous Rx mode MCS15 - HT 20(2x2)	85	0.026	mA
Continuous Tx mode 1 Mbps	304 [@20.5 dBm]	0.026	mA
Continuous Tx mode 54 Mbps[SISO]	295 [@19.5 dBm]	0.026	mA
Continuous Tx mode 54 Mbps[CDD]	553 [@19.5 dBm]	0.026	mA
Continuous Tx mode MCS7 - HT20[SISO]	265 [@17.5 dBm]	0.026	mA
Continuous Tx mode MCS7 - HT20[CDD]	481 [@17.5 dBm]	0.026	mA
Continuous Tx mode MCS8 - HT20	542 [@19 dBm]	0.026	mA
Continuous Tx mode MCS15 - HT20	540 [@17.5 dBm]	0.026	mA

Table 44: BCM43241 WLAN Current Consumption 2.4 GHz (Cont.)

Parameter	Typical, Host I/F=SDIO		Unit
	VBAT=3.6V	VDDIO=1.8V	

Note:

- All Tx powers are referred at chip output per core.
- Continuous Tx/Rx currents correspond to 100% duty-cycle and are measured using packet engine.
- Listen-current measured when no carrier is present.

Table 45: BCM43241 WLAN Current Consumption 5 GHz

Parameter	Typical, Host I/F=SDIO		Unit
	VBAT=3.6V	VDDIO=1.8V	
OFF (WL_REG_ON = Low, no VDDIO)	3	3	μA
Sleep (Interbeacon sleep)	4.3	153	μA
IEEE PS mode DTIM=1	1100	153	μA
IEEE PS mode DTIM=3	367	153	μA
Listen Current (1×1, OCL)	62	0.026	mA
Listen Current (2×2)	85	0.026	mA
Continuous Rx mode 6 Mbps(1×1 SCD)	67	0.026	mA
Continuous Rx mode 6 Mbps(2×2 MRC)	88	0.026	mA
Continuous Rx mode 54 Mbps(1×1 SCD)	67	0.026	mA
Continuous Rx mode 54 Mbps(2×2 MRC)	88	0.026	mA
Continuous Rx mode MCS7 - HT 20(1×1 SCD)	67	0.026	mA
Continuous Rx mode MCS7 - HT 20(2×2 MRC)	88	0.026	mA
Continuous Rx mode MCS7 - HT 40(1×1 SCD)	93	0.026	mA
Continuous Rx mode MCS7 - HT 40(2×2 MRC)	125	0.026	mA
Continuous Rx mode MCS8 - HT 20	91	0.026	mA
Continuous Rx mode MCS8 - HT 40	130	0.026	mA
Continuous Rx mode MCS15 - HT 20	96	0.026	mA
Continuous Rx mode MCS15 - HT 40	138	0.026	mA
Continuous Tx mode 6 Mbps[SISO]	270 [@18 dBm]	0.026	mA
Continuous Tx mode 6 Mbps[CDD]	485 [@18 dBm]	0.026	mA
Continuous Tx mode 54 Mbps[SISO]	268 [@18 dBm]	0.026	mA
Continuous Tx mode 54 Mbps[CDD]	485 [@18 dBm]	0.026	mA
Continuous Tx mode MCS7 - HT20[SISO]	269 [@17 dBm]	0.026	mA
Continuous Tx mode MCS7 - HT20[CDD]	486[@17 dBm]	0.026	mA
Continuous Tx mode MCS7 - HT40[SISO]	278 [@17 dBm]	0.026	mA
Continuous Tx mode MCS7 - HT40[CDD]	510 [@17 dBm]	0.026	mA

Table 45: BCM43241 WLAN Current Consumption 5 GHz (Cont.)

Parameter	Typical, Host I/F=SDIO		Unit
	VBAT=3.6V	VDDIO=1.8V	
Continuous Tx mode MCS8 - HT20	508 [@18 dBm]	0.026	mA
Continuous Tx mode MCS8 - HT40	547 [@18 dBm]	0.026	mA
Continuous Tx mode MCS15 - HT20	512 [@17 dBm]	0.026	mA
Continuos Tx mode MCS15 - HT40	540 [@17 dBm]	0.026	mA

Note:

- All Tx powers are referred at chip output per core.
- Continuous Tx/Rx currents correspond to 100% duty-cycle and are measured using packet engine.
- Listen-current measured when no carrier is present.

Not Recommended for New Designs

Bluetooth and FM Current Consumption

The Bluetooth and FM current consumption measurements are shown in [Table 46](#), [Table 47: “BLE Current Consumption,”](#) on page 147, and [Table 48: “FM Current Consumption,”](#) on page 147, respectively.



Note:

- The WLAN core is in reset (WL_REG_ON = low) for all measurements provided in [Table 46](#).
- For FM measurements, the Bluetooth core is in Sleep mode.
- The BT current consumption numbers are measured based on GFSK Tx output power = 13 dBm. The BLE current consumption numbers are measured based on a 10 dBm Tx output power.

Table 46: BT Current Consumption

<i>Parameters</i>	<i>Typical (V_{BAT} = 3.6V)</i>	<i>Typical (V_{IO} = 1.8V)</i>	<i>Unit</i>
HCI Mode	3.450	0.010	mA
Sleep with Ext LPO	0.009	0.082	mA
Reset	0.007	0.005	mA
Standard 1.28s Inquiry Scan	0.158	0.081	mA
Standard 2.56s Inquiry Scan	0.078	0.084	mA
Standard R1 Page and 1.28s Inquiry Scan	0.284	0.081	mA
Standard R1 Page and 2.56s Inquiry Scan	0.221	0.081	mA
Standard R2 Page and 2.56s Inquiry Scan	0.147	0.084	mA
500ms Sniff Att = 4 Master	0.126	0.084	mA
500ms Sniff Att = 4 Slave	0.108	0.084	mA
DM1DH1 Master TXRX	22.760	0.021	mA
DM1DH1 Slave TXRX	22.600	0.022	mA
DM3DH3 Master TXRX	28.149	0.031	mA
DM3DH3 Slave TXRX	27.900	0.032	mA
DM5DH5 Master TXRX	28.852	0.035	mA
DM5DH5 Slave TXRX	28.377	0.034	mA
3DH53DH1 Master TXRX	26.430	0.086	mA
3DH53DH1 Slave TXRX	26.234	0.086	mA
3DH53DH1 TX Master	28.843	0.028	mA
3DH53DH1 TX Slave	32.567	0.029	mA
3DH53DH1 RX Master	13.829	0.116	mA
3DH53DH1 RX Slave	13.753	0.117	mA
HV3 Master	10.391	0.041	mA
HV3 Slave	7.156	0.040	mA

Table 46: BT Current Consumption (Cont.)

Parameters	Typical (VBAT = 3.6V)	Typical (VIO = 1.8V)	Unit
HV3 Master R1 Page and 1.28s Inquiry Scan	10.635	0.041	mA
HV3 Slave R1 Page and 1.28s Inquiry Scan	7.835	0.040	mA
HV3 Master R1 Page and 2.56s Inquiry Scan	10.591	0.041	mA
HV3 Slave R1 Page and 2.56s Inquiry Scan	7.659	0.040	mA

Table 47: BLE Current Consumption

Parameter	Typical	Typical (VIO = 1.8V)	Unit
Adv - Unconnectable 1.00 sec	0.053	0.088	mA
Adv - Unconnectable 1.28 sec	0.041	0.087	mA
Adv - Unconnectable 2.00 sec	0.034	0.090	mA
Adv - Connectable 20 msec	1.876	0.089	mA
Scan 1.28 sec	0.150	0.087	mA
Connected 7.5 ms	3.002	0.012	mA
Connected 1 sec	0.153	0.088	mA
Connected 1.28 sec	0.148	0.087	mA
Connected 2 sec	0.138	0.088	mA

Table 48: FM Current Consumption

Parameter	Power	Typical (VBAT = 3.6V)	Typical (VIO = 1.8V)	Unit
FMRX: FM only and digital (I ² S) audio only	-47 dBm	6.198	0.220	mA
FMRX: FM + RDS and digital (I ² S) audio only	-	6.197	0.220	mA

Section 21: Interface Timing and AC Characteristics

SDIO/gSPI Timing

SDIO Default Mode Timing

SDIO default mode timing is shown by the combination of [Figure 41](#) and [Table 49](#).

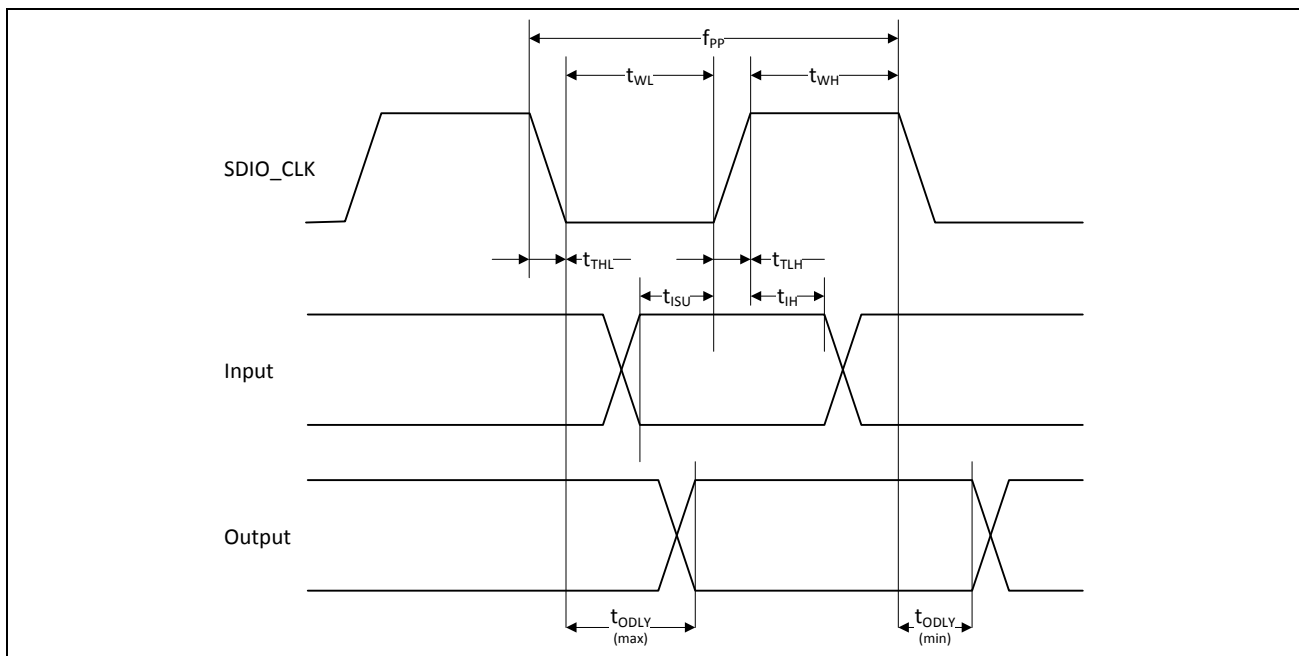

Figure 41: SDIO Bus Timing (Default Mode)

Table 49: SDIO Bus Timing^a Parameters (Default Mode)

Parameter	Symbol	Minimum	Typical	Maximum	Unit
SDIO CLK (All values are referred to minimum VIH and maximum VIL^b)					
Frequency – Data Transfer mode	f _{PP}	0	–	25	MHz
Frequency – Identification mode	f _{OD}	0	–	400	kHz
Clock low time	t _{WL}	10	–	–	ns
Clock high time	t _{WH}	10	–	–	ns
Clock rise time	t _{TLH}	–	–	10	ns
Clock low time	t _{THL}	–	–	10	ns

Not Recommended for New Designs

Table 49: SDIO Bus Timing^a Parameters (Default Mode) (Cont.)

Parameter	Symbol	Minimum	Typical	Maximum	Unit
Inputs: CMD, DAT (referenced to CLK)					
Input setup time	tISU	5	–	–	ns
Input hold time	tIH	5	–	–	ns
Outputs: CMD, DAT (referenced to CLK)					
Output delay time – Data Transfer mode	tODLY	0	–	14	ns
Output delay time – Identification mode	tODLY	0	–	50	ns

a. Timing is based on $CL \leq 40\text{pF}$ load on CMD and Data.

b. $\min(V_{ih}) = 0.7 \times V_{DDIO}$ and $\max(V_{il}) = 0.2 \times V_{DDIO}$.

SDIO High-Speed Mode Timing

SDIO high-speed mode timing is shown by the combination of Figure 42 and Table 50.

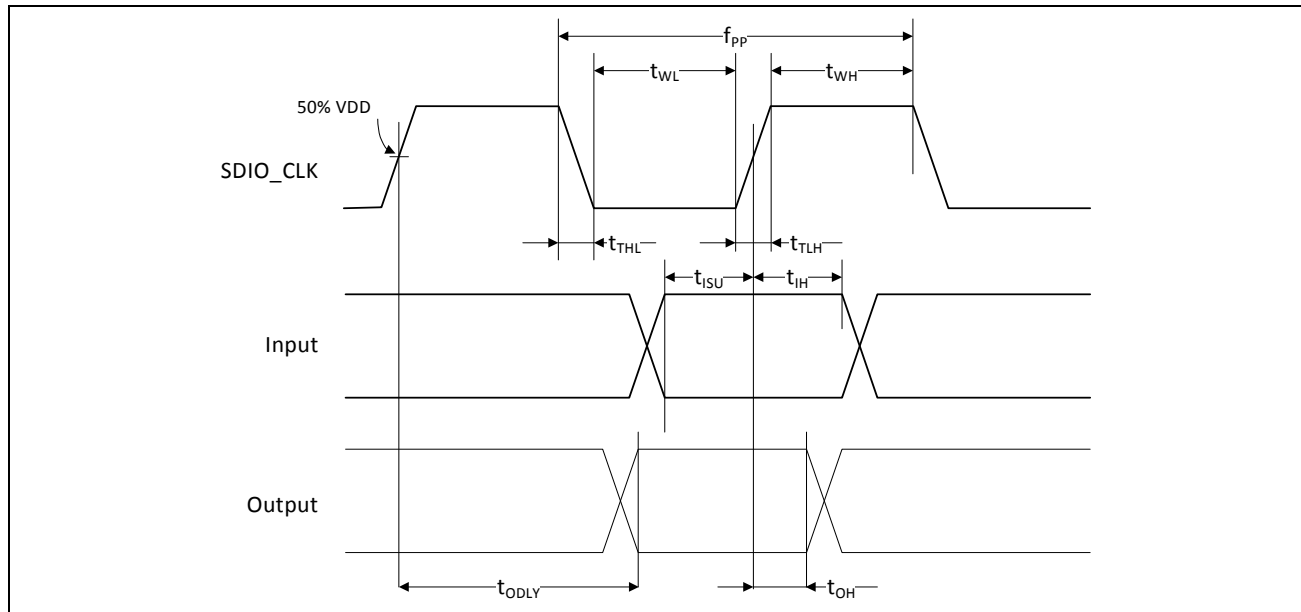

Figure 42: SDIO Bus Timing (High-Speed Mode)

Table 50: SDIO Bus Timing^a Parameters (High-Speed Mode)

Parameter	Symbol	Minimum	Typical	Maximum	Unit
SDIO CLK (all values are referred to minimum VIH and maximum VIL^b)					
Frequency – Data Transfer Mode	f _{PP}	0	–	50	MHz
Frequency – Identification Mode	f _{OD}	0	–	400	kHz
Clock low time	t _{WL}	7	–	–	ns
Clock high time	t _{WH}	7	–	–	ns
Clock rise time	t _{TLH}	–	–	3	ns
Clock low time	t _{THL}	–	–	3	ns
Inputs: CMD, DAT (referenced to CLK)					
Input setup Time	t _{ISU}	6	–	–	ns
Input hold Time	t _{IH}	2	–	–	ns
Outputs: CMD, DAT (referenced to CLK)					
Output delay time – Data Transfer Mode	t _{ODLY}	–	–	14	ns
Output hold time	t _{OH}	2.5	–	–	ns
Total system capacitance (each line)	CL	–	–	40	pF

a. Timing is based on CL ≤ 40 pF load on CMD and Data.

b. min(V_{IH}) = 0.7 × V_{DDIO} and max(V_{IL}) = 0.2 × V_{DDIO}.

Not Recommended for New Designs

SDIO Bus Timing Specifications in SDR Modes

Clock Timing

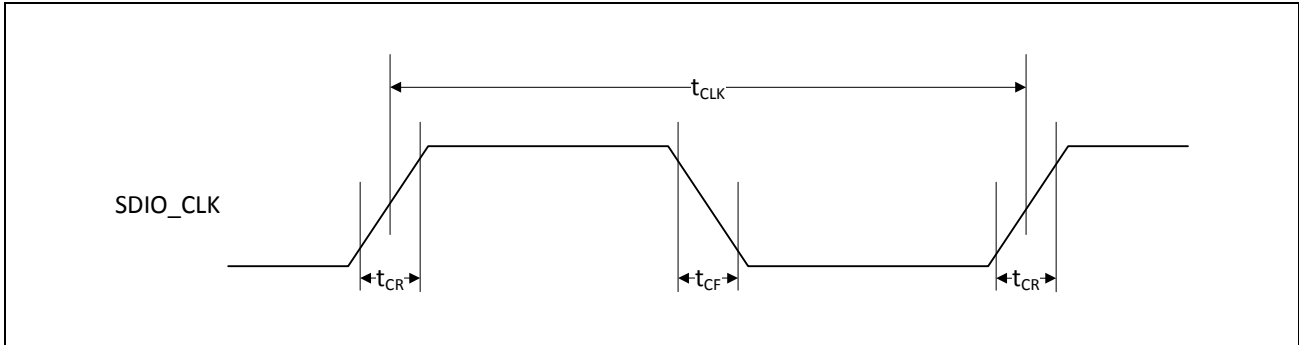

Figure 43: SDIO Clock Timing (SDR Modes)

Table 51: SDIO Bus Clock Timing Parameters (SDR Modes)

Parameter	Symbol	Minimum	Maximum	Unit	Comments
–	t_{CLK}	40	–	ns	SDR12 mode
		20	–	ns	SDR25 mode
		10	–	ns	SDR50 mode
		4.8	–	ns	SDR104 mode
–	t_{CR}, t_{CF}	–	$0.2 \times t_{CLK}$	ns	$t_{CR}, t_{CF} < 2.00$ ns (max) @100 MHz, $C_{CARD} = 10$ pF $t_{CR}, t_{CF} < 0.96$ ns (max) @208 MHz, $C_{CARD} = 10$ pF
Clock duty	–	30	70	%	–

Not Recommended for New Designs

Card Input Timing

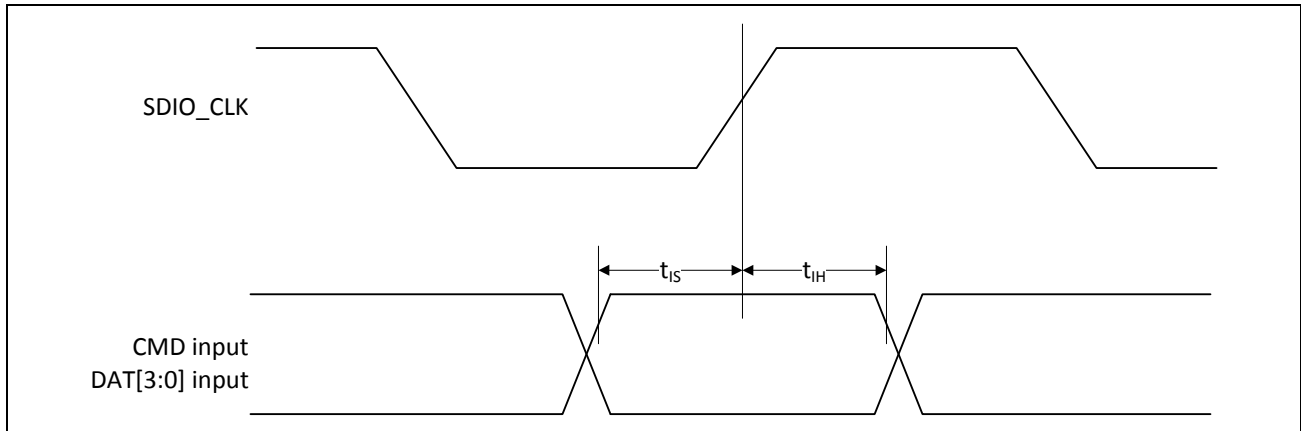

Figure 44: SDIO Bus Input Timing (SDR Modes)

Table 52: SDIO Bus Input Timing Parameters (SDR Modes)

Symbol	Minimum	Maximum	Unit	Comments
SDR104 Mode				
t_{IS}	1.70 ^a	–	ns	$C_{CARD} = 10 \text{ pF}$, $V_{CT} = 0.975V$
t_{IH}	0.80	–	ns	$C_{CARD} = 5 \text{ pF}$, $V_{CT} = 0.975V$
SDR50 Mode				
t_{IS}	3.00	–	ns	$C_{CARD} = 10 \text{ pF}$, $V_{CT} = 0.975V$
t_{IH}	0.80	–	ns	$C_{CARD} = 5 \text{ pF}$, $V_{CT} = 0.975V$

a. SDIO 3.0 specification value is 1.40 ns.

Not Recommended for New Designs

Card Output Timing

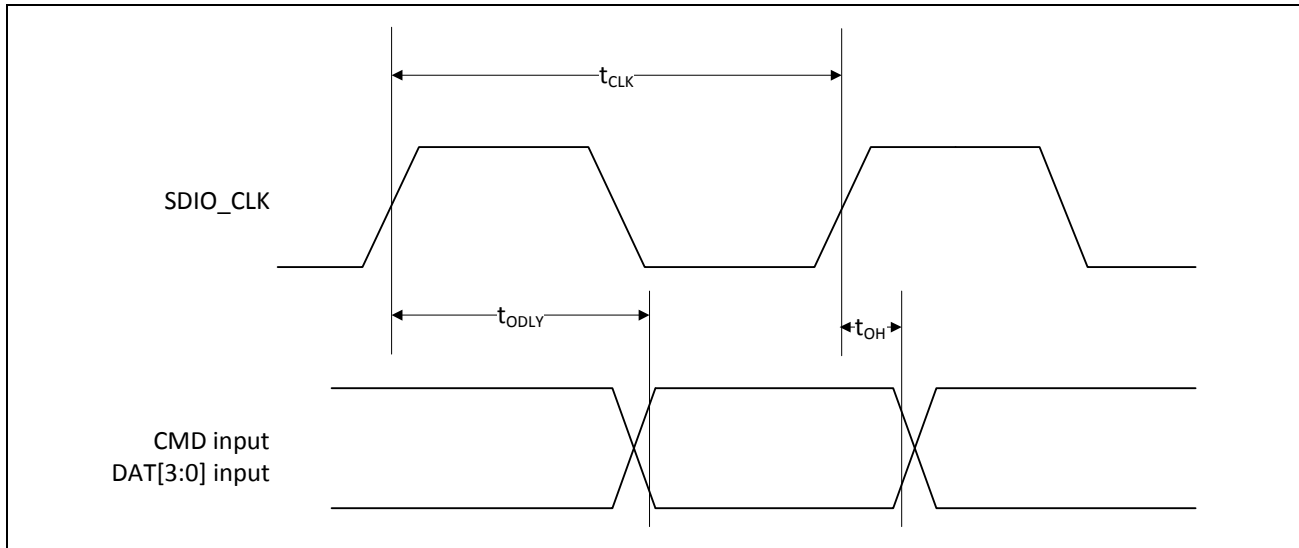

Figure 45: SDIO Bus Output Timing (SDR Modes up to 100 MHz)

Table 53: SDIO Bus Output Timing Parameters (SDR Modes up to 100 MHz)

Symbol	Minimum	Maximum	Unit	Comments
t_{ODLY}	–	7.85 ^a	ns	$t_{CLK} \geq 10$ ns $C_L = 30$ pF using driver type B for SDR50
t_{ODLY}	–	14.0	ns	$t_{CLK} \geq 20$ ns $C_L = 40$ pF using for SDR12, SDR25
t_{OH}	1.5	–	ns	Hold time at the t_{ODLY} (min) $C_L = 15$ pF

a. SDIO 3.0 specification value is 7.5 ns.

Not Recommended for New Designs

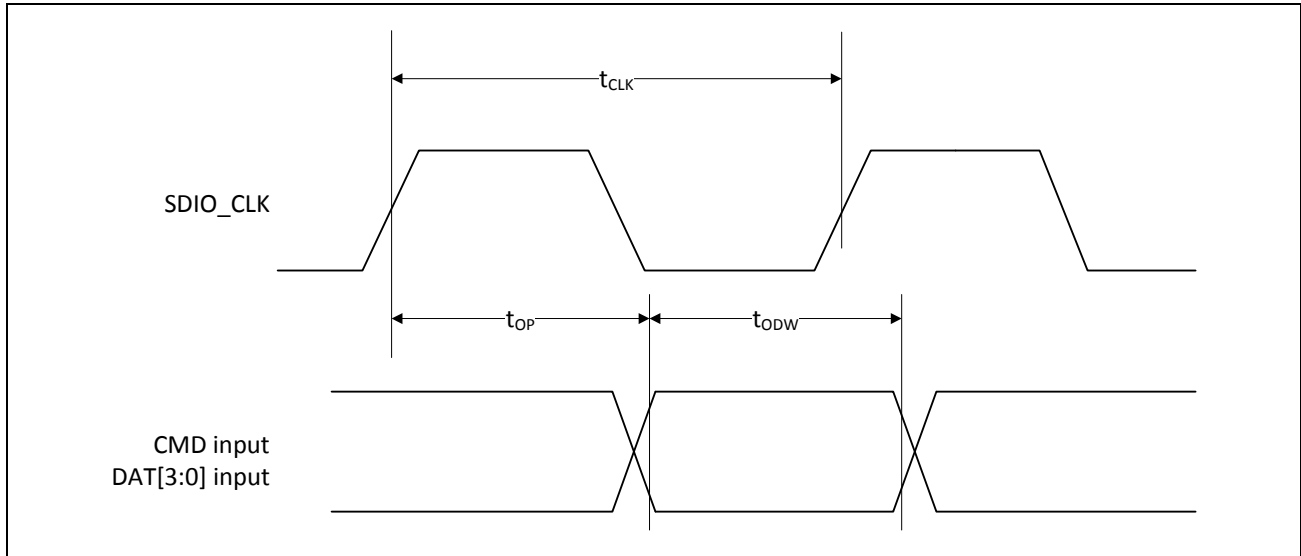

Figure 46: SDIO Bus Output Timing (SDR Modes 100 MHz to 208 MHz)

Table 54: SDIO Bus Output Timing Parameters (SDR Modes 100 MHz to 208 MHz)

Symbol	Minimum	Maximum	Unit	Comments
t_{OP}	0	2	UI	Card output phase
Δt_{OP}	-350	+1550	ps	Delay variation due to temp change after tuning
t_{ODW}	0.60	-	UI	$t_{ODW}=2.88$ ns @208 MHz

- $\Delta t_{OP} = +1550$ ps for junction temperature of $\Delta t_{OP} = 90$ degrees during operation
- $\Delta t_{OP} = -350$ ps for junction temperature of $\Delta t_{OP} = -20$ degrees during operation
- $\Delta t_{OP} = +2600$ ps for junction temperature of $\Delta t_{OP} = -20$ to $+125$ degrees during operation

Not Recommended for New Designs

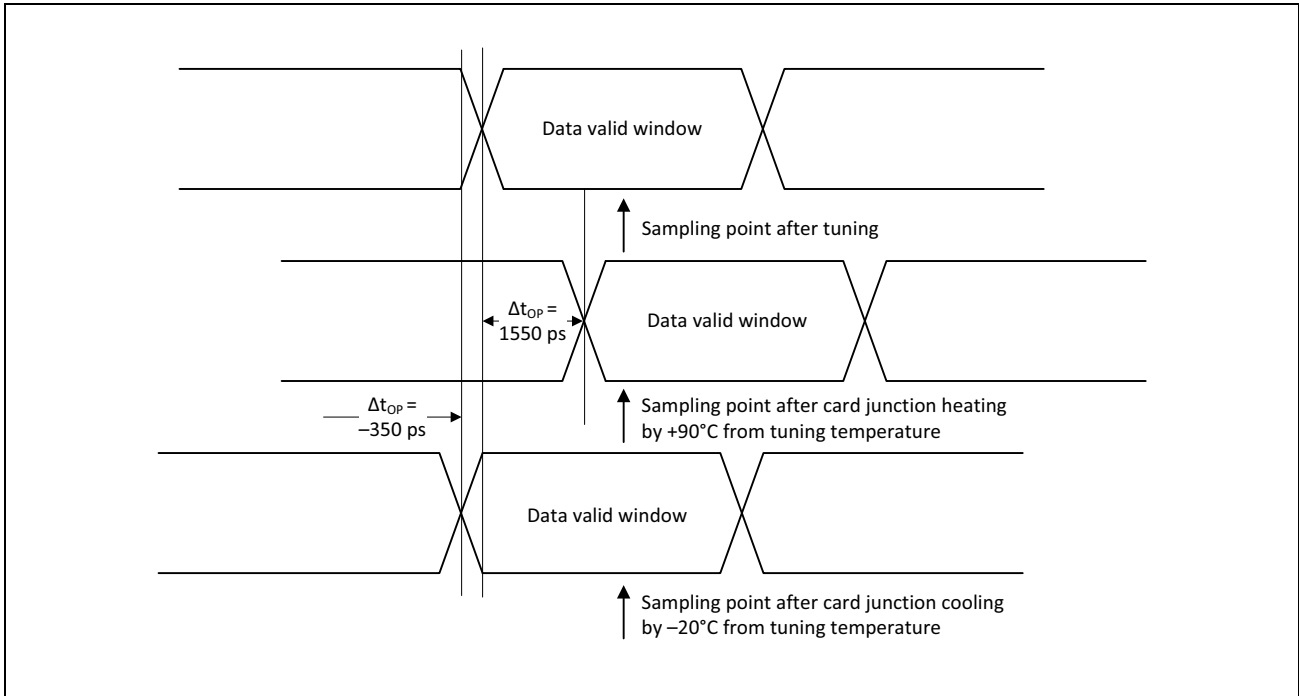

Figure 47: Δt_{OP} Consideration for Variable Data Window (SDR 104 Mode)

Not Recommended for New Designs

SDIO Bus Timing Specifications in DDR50 Mode

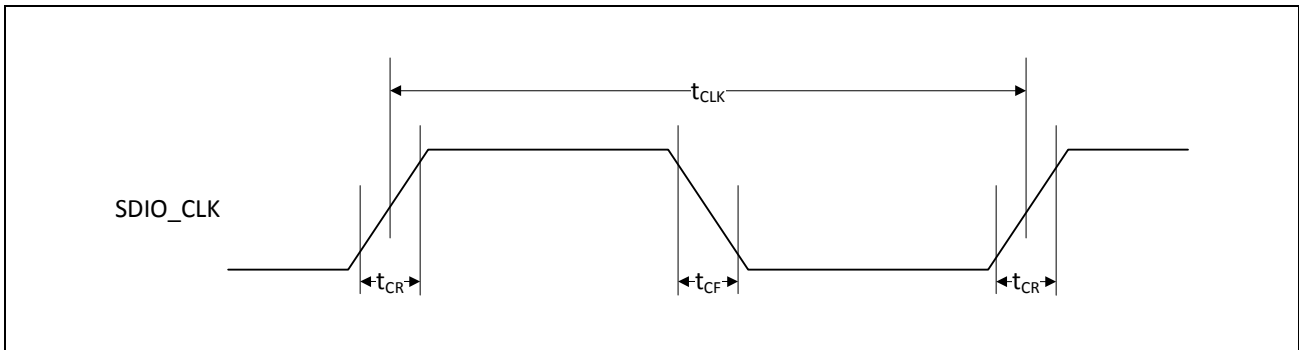

Figure 48: SDIO Clock Timing (DDR50 Mode)

Table 55: SDIO Bus Clock Timing Parameters (DDR50 Mode)

Parameter	Symbol	Minimum	Maximum	Unit	Comments
–	t_{CLK}	20	–	ns	DDR50 mode
–	t_{CR}, t_{CF}	–	$0.2 \times t_{CLK}$	ns	$t_{CR}, t_{CF} < 4.00$ ns (max) @50 MHz, $C_{CARD} = 10$ pF
Clock duty	–	45	55	%	–

Not Recommended for New Designs

Data Timing

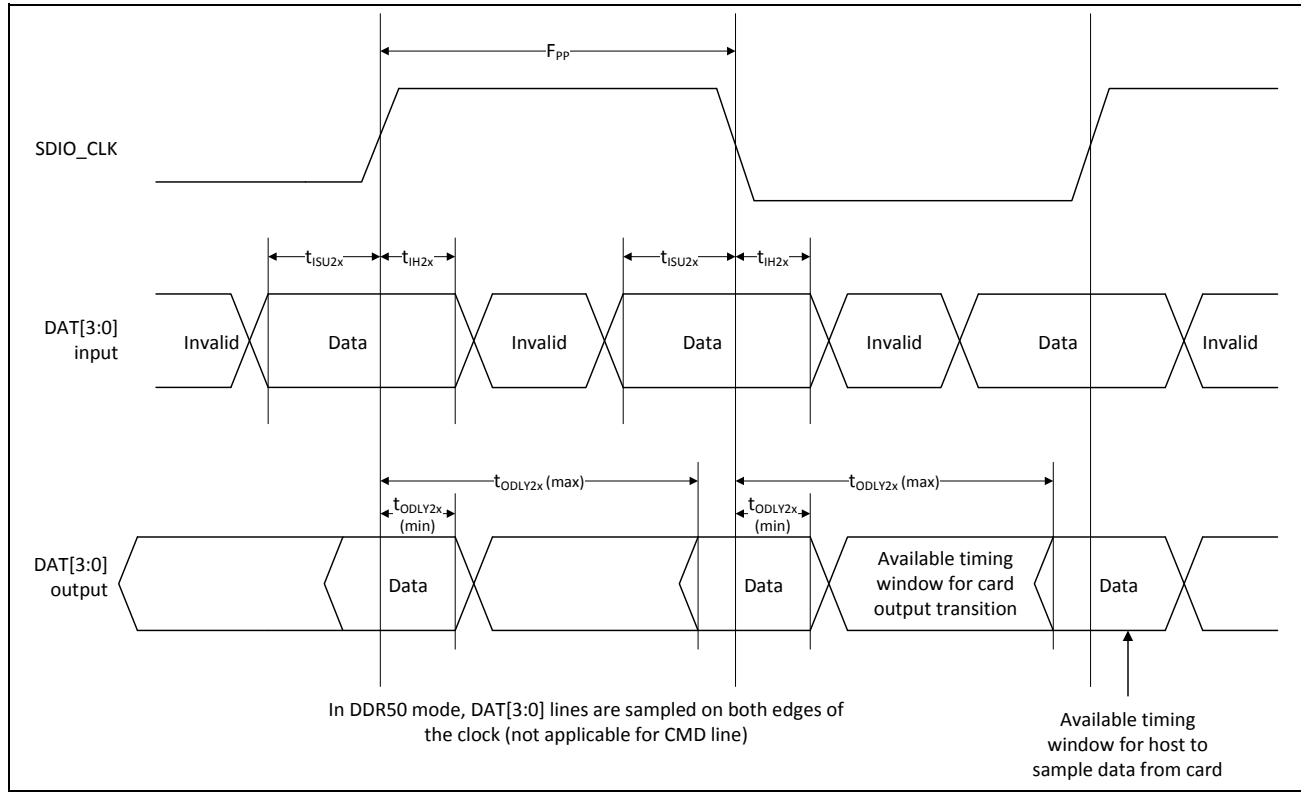

Figure 49: SDIO Data Timing (DDR50 Mode)

Table 56: SDIO Bus Timing Parameters (DDR50 Mode)

Parameter	Symbol	Minimum	Maximum	Unit	Comments
Input CMD					
Input setup time	t_{ISU}	6	–	ns	$C_{CARD} < 10pF$ (1 Card)
Input hold time	t_{IH}	0.8	–	ns	$C_{CARD} < 10pF$ (1 Card)
Output CMD					
Output delay time	t_{ODLY}	–	13.7	ns	$C_{CARD} < 30pF$ (1 Card)
Output hold time	t_{OH}	1.5	–	ns	$C_{CARD} < 15pF$ (1 Card)
Input DAT					
Input setup time	t_{ISU2x}	3	–	ns	$C_{CARD} < 10pF$ (1 Card)
Input hold time	t_{IH2x}	0.8	–	ns	$C_{CARD} < 10pF$ (1 Card)
Output DAT					
Output delay time	t_{ODLY2x}	–	7.85 ^a	ns	$C_{CARD} < 25pF$ (1 Card)
Output hold time	t_{ODLY2x}	1.5	–	ns	$C_{CARD} < 15pF$ (1 Card)

a. SDIO 3.0 specification value is 7.0 ns.

Not Recommended for New Designs

gSPI Signal Timing

The gSPI host and device always use the rising edge of clock to sample data.

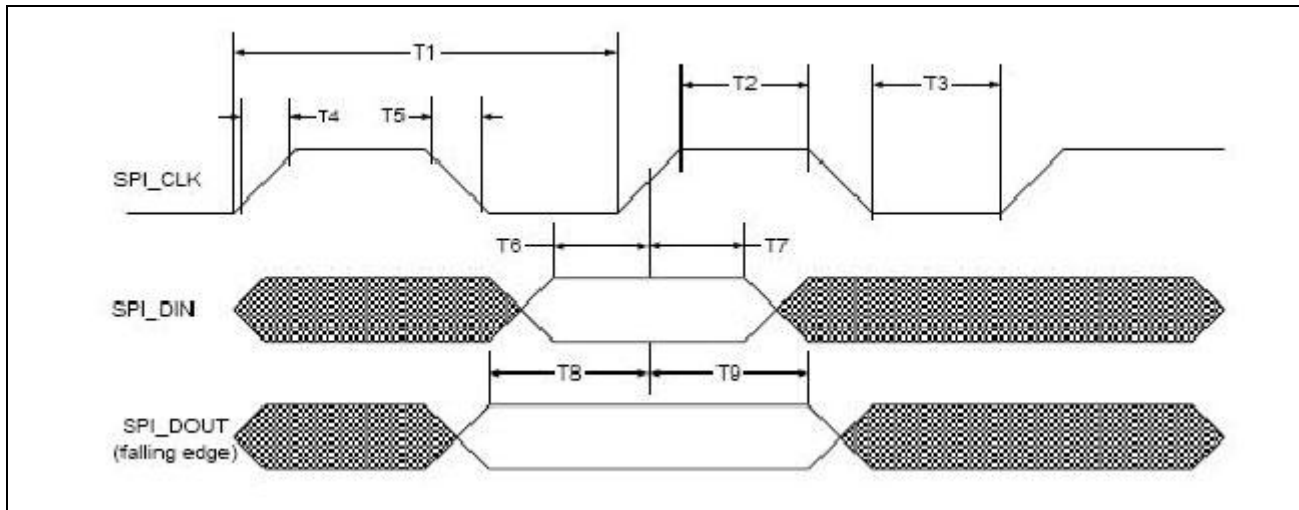

Figure 50: gSPI Timing

Table 57: gSPI Timing Parameters

Parameter	Symbol	Minimum	Maximum	Units	Note
Clock period	T1	20.8	–	ns	$F_{max} = 48 \text{ MHz}$
Clock high/low	T2/T3	$(0.45 \times T1) - T4$	$(0.55 \times T1) - T4$	ns	–
Clock rise/fall time ^a	T4/T5	–	2.5	ns	Measured from 10% to 90% of VDDIO
Input setup time	T6	5.0	–	ns	Setup time, SIMO valid to SPI_CLK active edge
Input hold time	T7	5.0	–	ns	Hold time, SPI_CLK active edge to SIMO invalid
Output setup time	T8	5.0	–	ns	Setup time, SOMI valid before SPI_CLK rising
Output hold time	T9	5.0	–	ns	Hold time, SPI_CLK active edge to SOMI invalid
CSX to clock ^b	–	7.86	–	ns	CSX fall to 1st rising edge
Clock to CSX ^a	–	–	–	ns	Last falling edge to CSX high

- a. Limit applies when SPI_CLK = Fmax. For slower clock speeds, longer rise/fall times are acceptable provided that the transitions are monotonic.
- b. SPI_CSx remains active for entire duration of gSPI read/write/write-read transaction (overall words for multiple-word transaction)

Not Recommended for New Designs

HSIC Interface Specifications

Table 58: HSIC Timing Parameters

Parameter	Symbol	Minimum	Typical	Maximum	Unit	Comments
HSIC signaling voltage	V_{DD}	1.1	1.2	1.3	V	–
I/O voltage input low	V_{IL}	–0.3	–	$0.35 \times V_{DD}$	V	–
I/O Voltage input high	V_{IH}	$0.65 \times V_{DD}$	–	$V_{DD} + 0.3$	V	–
I/O voltage output low	V_{OL}	–	–	$0.25 \times V_{DD}$	V	–
I/O voltage output high	V_{OH}	$0.75 \times V_{DD}$	–	–	V	–
I/O pad drive strength	O_D	40	–	60	Ω	Controlled output impedance driver
I/O weak keepers	I_L	20	–	70	mA	–
I/O input impedance	Z_I	100	–	–	k Ω	–
Total capacitive load ^a	C_L	3	–	14	pF	–
Characteristic trace impedance	T_I	45	50	55	Ω	–
Circuit board trace length	T_L	–	–	10	cm	–
Circuit board trace propagation skew ^b	T_S	–	–	15	ps	–
STROBE frequency ^c	F_{STROBE}	239.988	240	240.012	MHz	± 500 ppm
Slew rate (rise and fall) STROBE and DATA ^c	T_{slew}	$0.60 \times V_{DD}$	1.0	1.2	V/ns	Averaged from 30% ~ 70% points
Receiver data setup time (with respect to STROBE) ^c	T_s	300	–	–	ps	Measured at the 50% point
Receiver data hold time (with respect to STROBE) ^c	T_b	300	–	–	ps	Measured at the 50% point

- Total Capacitive Load (C_L), includes device Input/Output capacitance, and capacitance of a 50 Ω PCB trace with a length of 10 cm.
- Maximum propagation delay skew in STROBE or DATA with respect to each other. The trace delay should be matched between STROBE and DATA to ensure that the signal timing is within specification limits at the receiver.
- Jitter and duty cycle are not separately specified parameters, they are incorporated into the values in the table above.

Not Recommended for New Designs

JTAG Timing

Table 59: JTAG Timing Characteristics

<i>Signal Name</i>	<i>Period</i>	<i>Output Maximum</i>	<i>Output Minimum</i>	<i>Setup</i>	<i>Hold</i>
TCK	125 ns	–	–	–	–
TDI	–	–	–	20 ns	0 ns
TMS	–	–	–	20 ns	0 ns
TDO	–	100 ns	0 ns	–	–
JTAG_TRST	250 ns	–	–	–	–

Not Recommended for New Designs

Section 22: Power-Up Sequence and Timing

Sequencing of Reset and Regulator Control Signals

The BCM43241 has signals that allow the host to control power consumption by enabling or disabling the Bluetooth, WLAN, and internal regulator blocks. These signals are described below. Additionally, diagrams are provided to indicate proper sequencing of the signals for various operational states (see [Figure 51](#), [Figure 52 on page 162](#), and [Figure 53](#) and [Figure 54 on page 163](#)). The timing values indicated are minimum required values; longer delays are also acceptable.

**Note:**

- The WL_REG_ON and BT_REG_ON signals are ORed in the BCM43241. The diagrams show both signals going high at the same time (as would be the case if both REG signals were controlled by a single host GPIO). If two independent host GPIOs are used (one for WL_REG_ON and one for BT_REG_ON), then only one of the two signals needs to be high to enable the BCM43241 regulators.
- The reset requirements for the Bluetooth core are also applicable for the FM core. In other words, if FM is to be used, then the Bluetooth core must be enabled.
- The BCM43241 has an internal power-on reset (POR) circuit. The device will be held in reset for a maximum of 110 ms after VDDC and VDDIO have both passed the 0.6V threshold. Wait at least 150 ms after VDDC and VDDIO are available before initiating SDIO accesses.

Description of Control Signals

- **WL_REG_ON:** Used by the PMU to power up the WLAN section. It is also OR-gated with the BT_REG_ON input to control the internal BCM43241 regulators. When this pin is high, the regulators are enabled and the WLAN section is out of reset. When this pin is low, the WLAN section is in reset. If both the BT_REG_ON and WL_REG_ON pins are low, the regulators are disabled.
- **BT_REG_ON:** Used by the PMU (OR-gated with WL_REG_ON) to power up the internal BCM43241 regulators. If both the BT_REG_ON and WL_REG_ON pins are low, the regulators are disabled. When this pin is low and WL_REG_ON is high, the BT section is in reset.

Control Signal Timing Diagrams

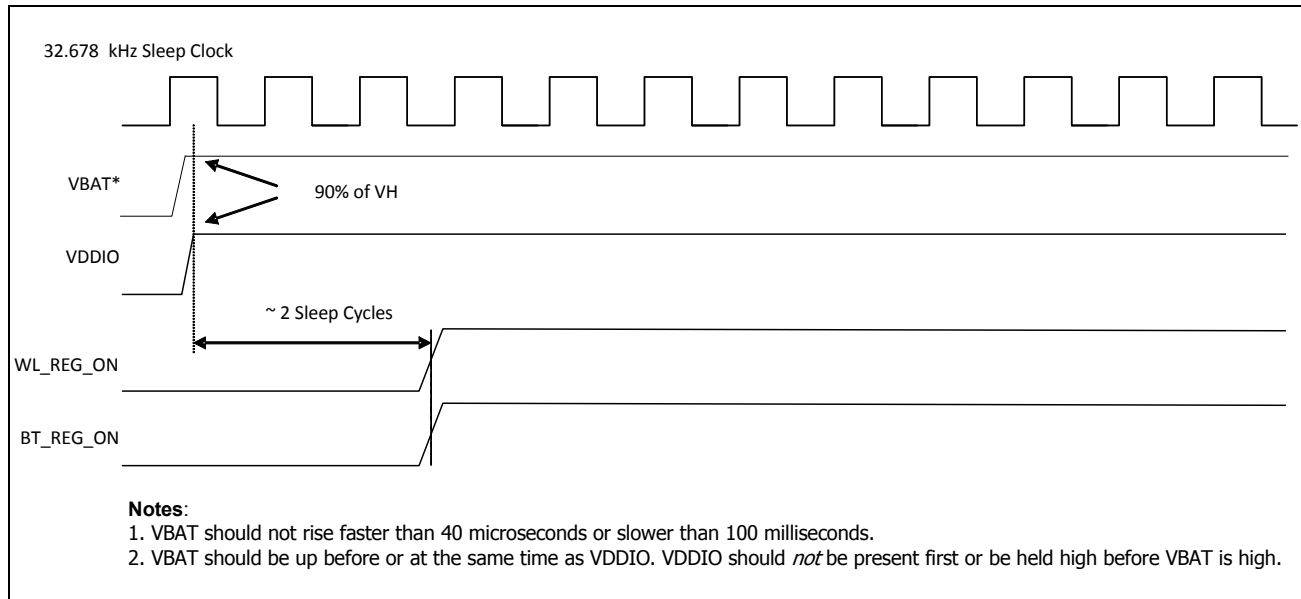

Figure 51: WLAN = ON, Bluetooth = ON

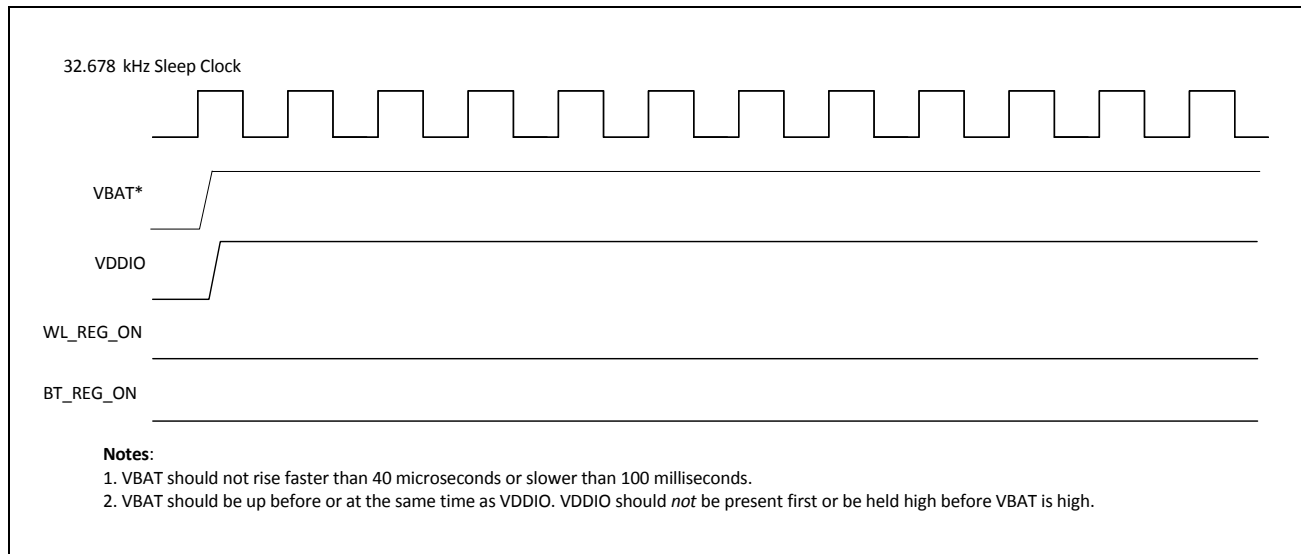

Figure 52: WLAN = OFF, Bluetooth = OFF

Not Recommended for New Designs

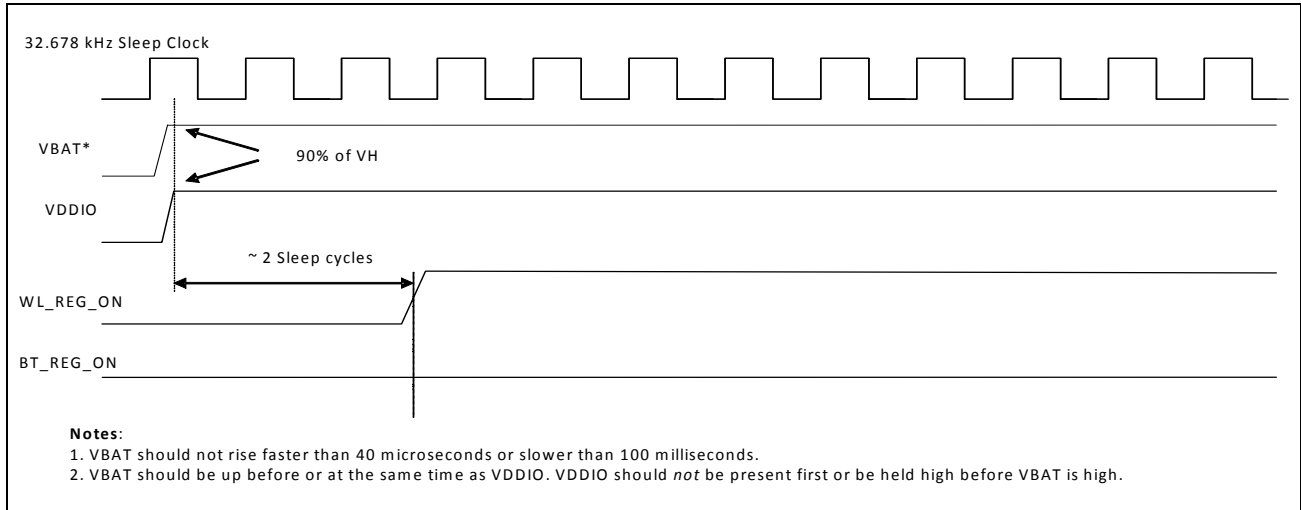

Figure 53: WLAN = ON, Bluetooth = OFF

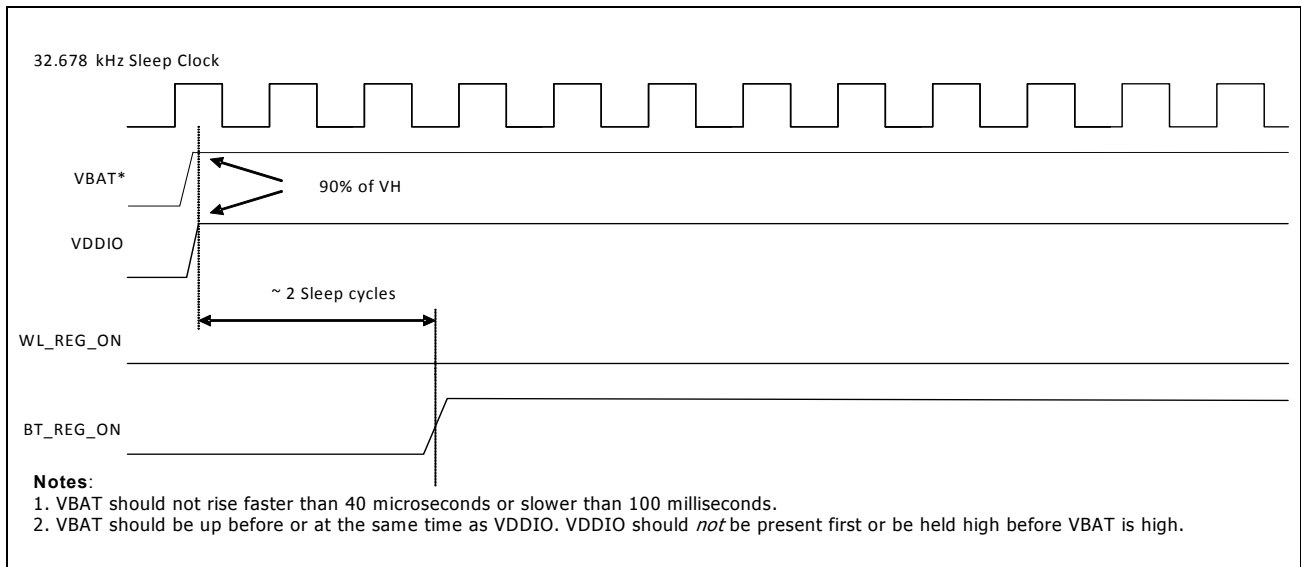

Figure 54: WLAN = OFF, Bluetooth = ON

Not Recommended for New Designs

Section 23: Package Information

Preliminary Package Thermal Characteristics

Table 60: Package JEDEC Thermal Characteristics^a

Characteristic	FCFBGA
θ_{JA} (°C/W) (value in still air)	36.30
θ_{JB} (°C/W)	10.84
θ_{JC} (°C/W)	18.57
Ψ_{JT} (°C/W)	8.89
Ψ_{JB} (°C/W)	15.67
Maximum junction temperature T_j^b	125
Maximum power dissipation (W)	1.66

a. No heat sink, $T_A = 55^\circ\text{C}$, $P = 1.66\text{W}$ continuous dissipation.

b. Absolute junction temperature limits are maintained through active thermal monitoring and turning off one of the Tx chains.

Junction Temperature Estimation and Ψ_{JT} Versus θ_{JC}

Package thermal characterization parameter Ψ_{JT} yields a better estimation of actual junction temperature (T_j) versus using the junction-to-case thermal resistance parameter θ_{JC} . The reason for this is that θ_{JC} assumes that all the power is dissipated through the top surface of the package case. In actual applications, some of the power is dissipated through the bottom and sides of the package. Ψ_{JT} takes into account power dissipated through the top, bottom, and sides of the package. The equation for calculating the device junction temperature is:

$$T_j = T_T + P \times \Psi_{JT}$$

Where:

- T_j = Junction temperature at steady-state condition (°C)
- T_T = Package case top center temperature at steady-state condition (°C)
- P = Device power dissipation (Watts)
- Ψ_{JT} = Package thermal characteristics; no airflow (°C/W)

Environmental Characteristics

For environmental characteristics data, see [Table 25: “Environmental Ratings,” on page 107.](#)

Section 24: Mechanical Information

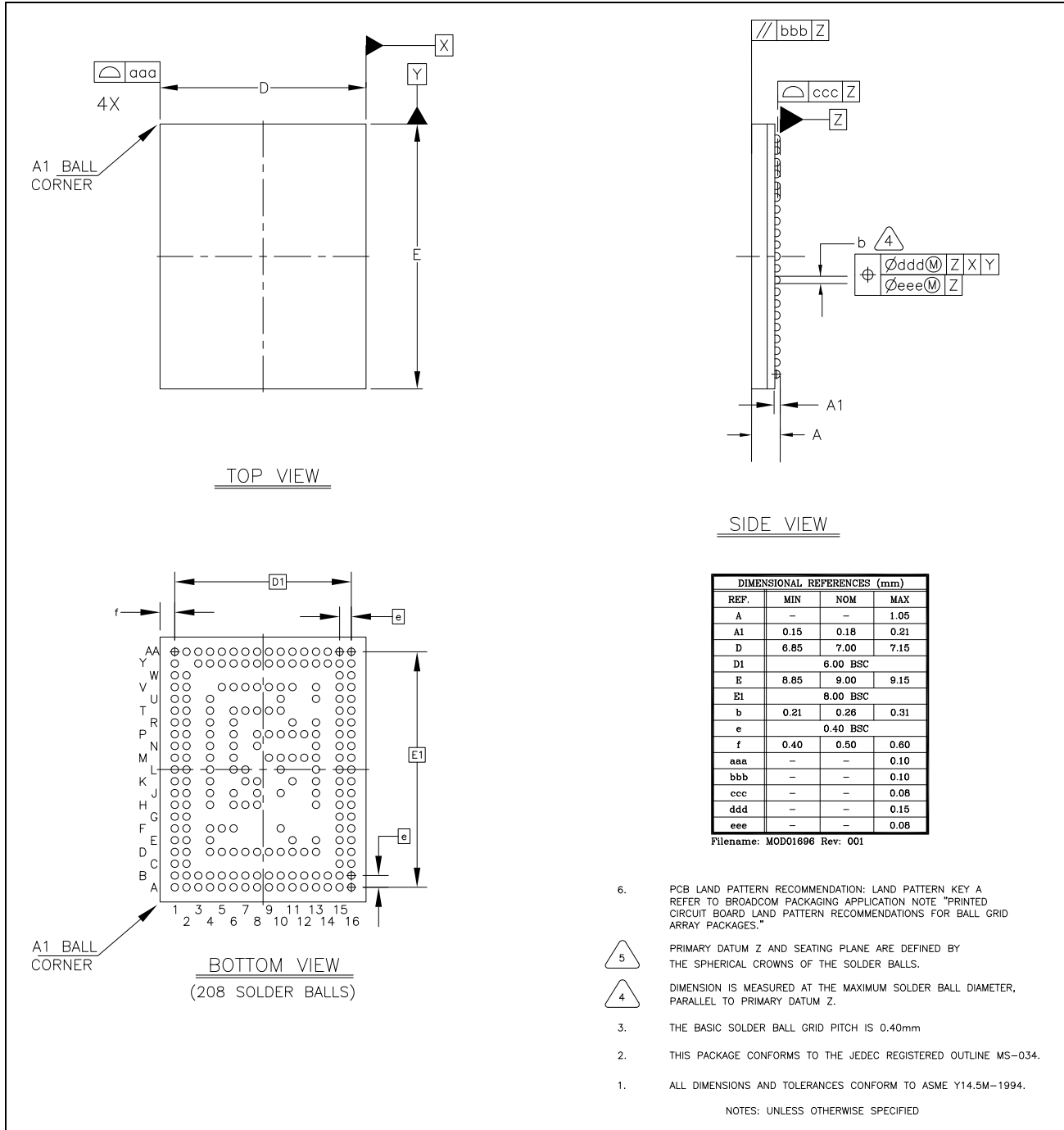

Figure 55: 208-Ball FCBGA Package Mechanical Information

Not Recommended for New Designs

Section 25: Ordering Information

<i>Part Number</i>	<i>Package</i>	<i>Description</i>	<i>Operating Ambient Temperature</i>
BCM43241FKFFBG	FCFBGA (7.00 mm x 9.00 mm, 0.4 mm pitch)	Single-band 2.4 GHz WLAN + BT 4.0 + FM Rx	-30°C to +85°C
BCM43241GKFFBG	FCFBGA (7.00 mm x 9.00 mm, 0.4 mm pitch)	Single-band 2.4 GHz WLAN + BT 4.0	-30°C to +85°C
BCM43241XKFFBG	FCFBGA (7.00 mm x 9.00 mm, 0.4 mm pitch)	Dual-band 2.4 GHz and 5 GHz WLAN + BT 4.0 + FM	-30°C to +85°C
BCM43241DKFFBG	FCFBGA (7.00 mm x 9.00 mm, 0.4 mm pitch)	Dual-band WLAN + BT 4.0	-30°C to +85°C
BCM43241ZKFFBG	FCFBGA (7.00 mm x 9.00 mm, 0.4 mm pitch)	Dual-band WLAN	-30°C to +85°C

Not Recommended for New Designs

Section 26: Pin List

This section presents the pin list for the BCM43241 device:

- [Table 61: “208-Pin FCBGA Package Pin List By Pin Number,” on page 167](#)
- [Table 62: “208-Pin FCBGA Package Pin List By Pin Name,” on page 170](#)

Table 61: 208-Pin FCBGA Package Pin List By Pin Number

Pin	Name	Pin	Name
A1	BT_UART_TXD	B15	SR_PVSS
A2	BT_LPO_IN	B16	SR_PVSS
A3	BT_PCM_CLK	C1	BT_I2S_CLK
A4	BT_PCM_OUT	C2	BT_UART_RTS_N
A5	RF_SW_CTRL_7	C15	SR_VDDBATP5V
A6	RF_SW_CTRL_5	C16	SR_VDDBATP5V
A7	RF_SW_CTRL_1	D1	BT_I2S_DO
A8	GMODE_EXT_LNA_PU_CORE0	D2	BT_VDDC_ISO_2
A9	GMODE_PA_EN_CORE0	D4	BT_PCM_SYNC
A10	GPIO_7	D5	BT_GPIO_2
A11	GPIO_6	D6	RF_SW_CTRL_4
A12	GPIO_3/TMS	D7	RF_SW_CTRL_0
A13	GPIO_0/WL_HOST_WAKE	D8	RF_SW_CTRL_2
A14	GPIO_1/WL_DEV_WAKE	D9	GPIO_12
A15	SR_VLX	D10	AMODE_EXT_LNA_PU_CORE0
A16	SR_VLX	D11	GPIO_11
B1	BT_UART_RXD	D12	GPIO_5/TDO/UART_TX
B2	BT_GPIO_4	D13	PMU_AVSS
B3	BT_I2S_WS	D15	SR_VDDBATA5V
B4	BT_GPIO_3	D16	SR_VDDBATA5V
B5	BT_PCM_IN	E1	BT_CLK_REQ
B6	RF_SW_CTRL_6	E2	BT_I2S_DI
B7	RF_SW_CTRL_3	E4	BT_VDDC_ISO_1
B8	AMODE_PA_EN_CORE0	E11	GPIO_9
B9	GPIO_13	E13	VOUT_LDO3P3
B10	GPIO_8	E15	VOUT_CLDO
B11	GPIO_2/TCK	E16	VOUT_CLDO
B12	JTAG_SEL	F1	BT_HOST_WAKE
B13	EXT_XTAL_PU	F2	BT_UART_CTS_N
B14	SR_PVSS	F4	BT_VDDO

Not Recommended for New Designs

Pin	Name	Pin	Name
F5	BT_VDDC	L4	BTFM_RGND
F6	BT_VDDC	L6	VSS
F10	GPIO_4/TDI/UART_RX	L7	GPIO_10
F15	VOUT_LNLD01	L10	OTP_VDD33
F16	VOUT_LNLD01	L13	VSS
G1	BT_TM1	L15	SDIO_DATA_1
G2	BT_DEV_WAKE	L16	SDIO_DATA_3
G15	LDO_VDD1P5	M1	BT_LNAVDD
G16	LDO_VDD1P5	M2	BTFM_RGND
H1	FM_VCOVDD	M4	BT_PLLVDD
H2	BTFM_RGND	M6	GPIO_15
H4	BT_GPIO_5	M9	VSS
H6	BT_VDDC	M10	VDD
H7	VSS	M11	VDDIO_RF
H8	VDD	M12	VDDIO_SD
H13	VOUT_LNLD02	M13	HSIC_AGND12PLL
H15	VOUT_HSICAVDD	M15	SDIO_DATA_0
H16	HSIC_STROBE	M16	SDIO_CLK
J1	FM_LNAVDD	N1	BT_RF
J2	BTFM_RGND	N2	BTFM_RGND
J4	FM_PLLVDD	N4	BTFM_RGND
J6	VSS	N6	GPIO_14
J8	VDDIO_RF	N8	VDD
J10	VSS	N13	RF_SW_CTRL_9
J13	WLREG_ON	N15	RF_SW_CTRL_11
J15	HSIC_RREFHSIC	N16	SDIO_CMD
J16	HSIC_DATA	P1	BT_PAVDD
K1	FM_RFIN	P2	BT_VBAT
K2	FM_RFAUX	P4	BT_IFVDD
K4	BTFM_RGND	P6	VSS
K7	VDD	P8	VDD
K8	VDD	P9	VSS
K11	VDDIO	P10	VDD
K13	BTREG_ON	P11	RF_SW_CTRL_8
K15	HSIC_DVDD1P2	P12	PALDO_PU
K16	SDIO_DATA_2	P13	GMODE_EXT_LNA_PU_CORE1
L1	BT_VCOVDD	P15	AMODE_EXT_LNA_PU_CORE1
L2	BTFM_RGND	P16	RF_SW_CTRL_10

Not Recommended for New Designs

<i>Pin</i>	<i>Name</i>
R1	WRF_RFIN_2G_CORE0
R2	RGND
R4	RGND
R6	VSS
R11	GMODE_PA_EN_CORE1
R13	AMODE_PA_EN_CORE1
R15	VSS
R16	AVDD_BBPLL
T1	RGND
T2	WRF_RX2G_VDD1P2_CORE0
T4	WRF_PADRV2G_VDD3P3_CORE0
T6	RGND
T7	RGND
T8	RGND
T9	VSS
T10	RGND
T15	WRF_XTAL_CAB_GND1P2
T16	WRF_TCXO_CKIN2V
U1	WRF_PAOUT_2G_CORE0
U2	RGND
U4	RGND
U10	WRF_AFE_VDD1P2_CORE1
U13	WRF_TCXO_VDD1P8
U15	WRF_XTAL_CAB_GND1P2
U16	WRF_XTAL_CAB_XON
V1	WRF_PA_VDD3P3_CORE0
V2	RGND
V5	WRF_PADRV5G_VDD3P3_CORE0
V6	RGND
V7	WRF_AFE_VDD1P2_CORE0
V8	RGND
V9	RGND
V10	RGND
V11	RGND
V13	WRF_PADRV5G_VDD3P3_CORE1
V15	WRF_XTAL_CAB_VDD1P2
V16	WRF_XTAL_CAB_XOP
W1	WRF_PAOUT_5G_CORE0

<i>Pin</i>	<i>Name</i>
W2	RGND
W15	RGND
W16	RGND
Y1	RGND
Y3	RGND
Y4	RGND
Y5	RGND
Y6	WRF_TX_VDD1P2_CORE0
Y7	WRF_GPIO_OUT
Y8	WRF_TX_VDD1P2_CORE1
Y9	RGND
Y10	RGND
Y11	WRF_PADRV2G_VDD3P3_CORE1
Y12	RGND
Y13	RGND
Y14	RGND
Y15	RGND
Y16	WRF_RX5G_VDD1P2_CORE1
AA1	WRF_RFIN_5G_CORE0
AA2	RGND
AA3	WRF_RX5G_VDD1P2_CORE0
AA4	RGND
AA5	WRF_SYNTX_VDD1P2
AA6	RGND
AA7	WRF_VCO_VDD1P2
AA8	WRF_RX2G_VDD1P2_CORE1
AA9	WRF_RFIN_2G_CORE1
AA10	RGND
AA11	WRF_PAOUT_2G_CORE1
AA12	WRF_PA_VDD3P3_CORE1
AA13	WRF_PAOUT_5G_CORE1
AA14	RGND
AA15	WRF_RFIN_5G_CORE1
AA16	RGND

Not Recommended for New Designs

Table 62: 208-Pin FCBGA Package Pin List By Pin Name

Name	Pin	Name	Pin
AMODE_EXT_LNA_PU_CORE0	D10	BT_VDDC_ISO_2	D2
AMODE_EXT_LNA_PU_CORE1	P15	BT_VDDO	F4
AMODE_PA_EN_CORE0	B8	BTFM_RGND	H2
AMODE_PA_EN_CORE1	R13	BTFM_RGND	J2
AVDD_BBPLL	R16	BTFM_RGND	K4
BT_CLK_REQ	E1	BTFM_RGND	L2
BT_DEV_WAKE	G2	BTFM_RGND	L4
BT_GPIO_2	D5	BTFM_RGND	M2
BT_GPIO_3	B4	BTFM_RGND	N2
BT_GPIO_4	B2	BTFM_RGND	N4
BT_GPIO_5	H4	BTREG_ON	K13
BT_HOST_WAKE	F1	EXT_XTAL_PU	B13
BT_I2S_CLK	C1	FM_LNAVDD	J1
BT_I2S_DI	E2	FM_PLLVDD	J4
BT_I2S_DO	D1	FM_RFAUX	K2
BT_I2S_WS	B3	FM_RFIN	K1
BT_IFVDD	P4	FM_VCOVDD	H1
BT_LNAVDD	M1	GMODE_EXT_LNA_PU_CORE0	A8
BT_LPO_IN	A2	GMODE_EXT_LNA_PU_CORE1	P13
BT_PAVDD	P1	GMODE_PA_EN_CORE0	A9
BT_PCM_CLK	A3	GMODE_PA_EN_CORE1	R11
BT_PCM_IN	B5	GPIO_0/WL_HOST_WAKE	A13
BT_PCM_OUT	A4	GPIO_1/WL_DEV_WAKE	A14
BT_PCM_SYNC	D4	GPIO_10	L7
BT_PLLVDD	M4	GPIO_11	D11
BT_RF	N1	GPIO_12	D9
BT_TM1	G1	GPIO_13	B9
BT_UART_CTS_N	F2	GPIO_14	N6
BT_UART_RTS_N	C2	GPIO_15	M6
BT_UART_RXD	B1	GPIO_2/TCK	B11
BT_UART_TXD	A1	GPIO_3/TMS	A12
BT_VBAT	P2	GPIO_4/TDI/UART_RX	F10
BT_VCOVDD	L1	GPIO_5/TDO/UART_TX	D12
BT_VDDC	F5	GPIO_6	A11
BT_VDDC	F6	GPIO_7	A10
BT_VDDC	H6	GPIO_8	B10
BT_VDDC_ISO_1	E4	GPIO_9	E11

Not Recommended for New Designs

<i>Name</i>	<i>Pin</i>	<i>Name</i>	<i>Pin</i>
HSIC_AGND12PLL	M13	RGND	W2
HSIC_DATA	J16	RGND	W15
HSIC_DVDD1P2	K15	RGND	W16
HSIC_RREFHSIC	J15	RGND	Y1
HSIC_STROBE	H16	RGND	Y3
JTAG_SEL	B12	RGND	Y4
LDO_VDD1P5	G15	RGND	Y5
LDO_VDD1P5	G16	RGND	Y9
OTP_VDD33	L10	RGND	Y10
PALDO_PU	P12	RGND	Y12
PMU_AVSS	D13	RGND	Y13
RF_SW_CTRL_0	D7	RGND	Y14
RF_SW_CTRL_1	A7	RGND	Y15
RF_SW_CTRL_10	P16	RGND	AA2
RF_SW_CTRL_11	N15	RGND	AA4
RF_SW_CTRL_2	D8	RGND	AA6
RF_SW_CTRL_3	B7	RGND	AA10
RF_SW_CTRL_4	D6	RGND	AA14
RF_SW_CTRL_5	A6	RGND	AA16
RF_SW_CTRL_6	B6	SDIO_CLK	M16
RF_SW_CTRL_7	A5	SDIO_CMD	N16
RF_SW_CTRL_8	P11	SDIO_DATA_0	M15
RF_SW_CTRL_9	N13	SDIO_DATA_1	L15
RGND	R2	SDIO_DATA_2	K16
RGND	R4	SDIO_DATA_3	L16
RGND	T1	SR_PVSS	B14
RGND	T6	SR_PVSS	B15
RGND	T7	SR_PVSS	B16
RGND	T8	SR_VDDBATA5V	D15
RGND	T10	SR_VDDBATA5V	D16
RGND	U2	SR_VDDBATP5V	C15
RGND	U4	SR_VDDBATP5V	C16
RGND	V2	SR_VLX	A15
RGND	V6	SR_VLX	A16
RGND	V8	VDD	H8
RGND	V9	VDD	K7
RGND	V10	VDD	K8
RGND	V11	VDD	M10

Not Recommended for New Designs

<i>Name</i>	<i>Pin</i>	<i>Name</i>	<i>Pin</i>
VDD	N8	WRF_PAOUT_5G_CORE1	AA13
VDD	P8	WRF_RFIN_2G_CORE0	R1
VDD	P10	WRF_RFIN_2G_CORE1	AA9
VDDIO	K11	WRF_RFIN_5G_CORE0	AA1
VDDIO_RF	J8	WRF_RFIN_5G_CORE1	AA15
VDDIO_RF	M11	WRF_RX2G_VDD1P2_CORE0	T2
VDDIO_SD	M12	WRF_RX2G_VDD1P2_CORE1	AA8
VOUT_CLDO	E15	WRF_RX5G_VDD1P2_CORE0	AA3
VOUT_CLDO	E16	WRF_RX5G_VDD1P2_CORE1	Y16
VOUT_HSCAVDD	H15	WRF_SYNTN_VDD1P2	AA5
VOUT_LDO3P3	E13	WRF_TCXO_CKIN2V	T16
VOUT_LNLDO1	F15	WRF_TCXO_VDD1P8	U13
VOUT_LNLDO1	F16	WRF_TX_VDD1P2_CORE0	Y6
VOUT_LNLDO2	H13	WRF_TX_VDD1P2_CORE1	Y8
VSS	H7	WRF_VCO_VDD1P2	AA7
VSS	J6	WRF_XTAL_CAB_GND1P2	T15
VSS	J10	WRF_XTAL_CAB_GND1P2	U15
VSS	L6	WRF_XTAL_CAB_VDD1P2	V15
VSS	L13	WRF_XTAL_CAB_XON	U16
VSS	M9	WRF_XTAL_CAB_XOP	V16
VSS	P6		
VSS	P9		
VSS	R6		
VSS	R15		
VSS	T9		
WLREG_ON	J13		
WRF_AFE_VDD1P2_CORE0	V7		
WRF_AFE_VDD1P2_CORE1	U10		
WRF_GPIO_OUT	Y7		
WRF_PA_VDD3P3_CORE0	V1		
WRF_PA_VDD3P3_CORE1	AA12		
WRF_PADRV2G_VDD3P3_CORE0	T4		
WRF_PADRV2G_VDD3P3_CORE1	Y11		
WRF_PADRV5G_VDD3P3_CORE0	V5		
WRF_PADRV5G_VDD3P3_CORE1	V13		
WRF_PAOUT_2G_CORE0	U1		
WRF_PAOUT_2G_CORE1	AA11		
WRF_PAOUT_5G_CORE0	W1		

Not Recommended for New Designs

Broadcom® Corporation reserves the right to make changes without further notice to any products or data herein to improve reliability, function, or design.

Information furnished by Broadcom Corporation is believed to be accurate and reliable. However, Broadcom Corporation does not assume any liability arising out of the application or use of this information, nor the application or use of any product or circuit described herein, neither does it convey any license under its patent rights nor the rights of others.

Connecting
everything®



BROADCOM CORPORATION

5300 California Avenue

Irvine, CA 92617

© 2012 by BROADCOM CORPORATION. All rights reserved.

Phone: 949-926-5000

Fax: 949-926-5203

E-mail: info@broadcom.com

Web: www.broadcom.com