

PRINT DIMENSIONS IN INCHES. DO NOT SCALE PRINT

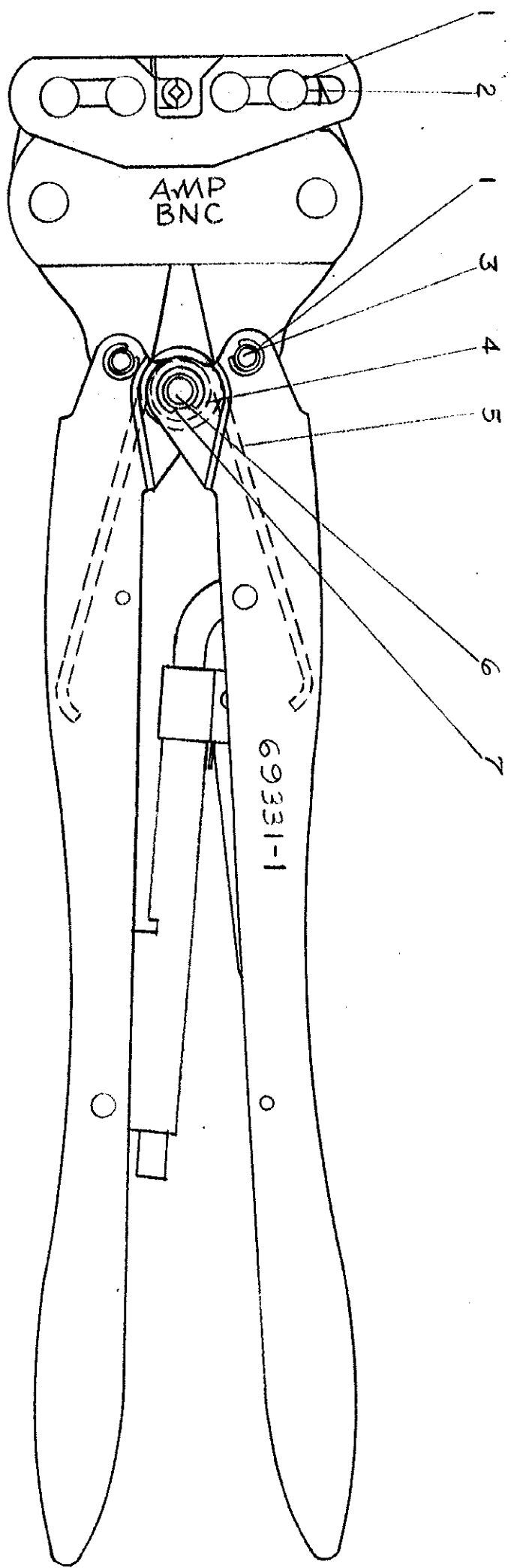

SUPERSEDED BY IS 2340

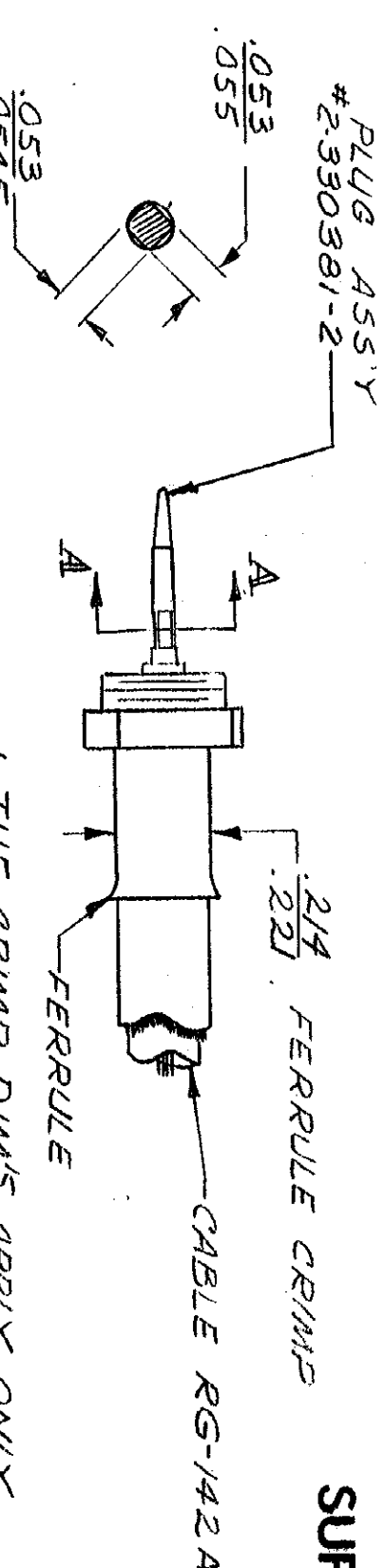

SECTION A-A
CENTER CONTACT CRIMP
METHOD OF GAGING CRIMP DIMENSIONS

1. THE CRIMP DIMS APPLY ONLY TO THE ABOVE COMBINATIONS

For replacement of parts other than listed, Tool should be returned to our Factory to insure proper Certifying adjustments.

ITEM NO	NUMBER	NAME	REMARKS
1	21045-6	RING-RETAINING	
2	300449	PIN-RETAINING	
3	39364	SPRING	
4	39366	COLLAR	
5	38783	PIN-RETAINING	
6	1-304197-0	PIN-RETAINING	
7	21045-3	RING-RETAINING	

LTR	REVISION RECORD	DR	CHK	DATE
A	REVISED	BKS		1/16/63
B	REVISED	CM		1/30/63
C	REVISED	LD		4/24
D	REVISED	B.S.		8-3
E	REVISED	PL BIF		11/25/63
F1	SUPD BY IS-2340	B.S.		7/28

NUMBER	DESCRIPTION
69331-1	

DR 2-27-63
CHK J. O'Connell
MATERIAL AND FINISH
WIRE - RANGE - INSULATION
RG-142A
TOLERANCE EXCEPT AS NOTED = 10'
SCALE 1-1
LOC M
NO B
REV E1

AMP INCORPORATED, ALL RIGHTS RESERVED.
AMP PRODUCTS COVERED BY PATENTS AND/OR PATENTS PENDING.
AMP INCORPORATED HARRISBURG, PENNA.
CLASS BNC COAXIAL
CUSTOMER COPY REFERENCE ONLY
NAME HAND TOOL ASSEMBLY

7 6 5 4 3 2 1